

Overview

The KEMET T330 polar-type, radial lead, rectangular Precision Molded Tantalum (PMT) capacitors are primarily designed for applications that demand full use of the premium space available in printed circuitry and high density packaging. Compact, space saving T330 capacitors provide superior packing factor and space utilization as compared with tubular units of the same microcoulomb (CV) rating.

T330 capacitors employ a rectangular sintered, dry tantalum anode, transfer molded in precision, with a high impact resistant plastic for excellent electrical, physical and moisture resistant properties. All cases are constructed with a gold color plastic which permits laser marking with outstanding permanency and legibility. The polarity is indicated by a + sign permanently marked on the case. The radius on the two vertical edges at the positive end of B, C, and D cases can be used as a sensing dimension for automatic insertion processes. The location of the

standoffs may serve a similar sensing function for the A case. These standoffs, located in the base of all case sizes, provide vents for air circulation and also allow easy removal of flux residues from leadwire and circuit board solder joints.

T330 capacitors are highly reliable and exhibit performance characteristics typical of military test standards. They are available in capacitance values ranging from 0.1 to 220 μF , in $\pm 20\%$, $\pm 10\%$, and $\pm 5\%$ tolerance levels and in working voltages from 6 to 50 VDC. The capacitors will operate continuously at full rated voltage at 85°C and are rated to 125°C when operated at 2/3 of nameplate voltage. In addition, the T330 features exceptionally low DC leakage and dissipation factor characteristics. These parts are ideal for bypass, coupling, and timing applications in computers, military ordinance, industrial, entertainment and consumer electronic equipment.

Benefits

- Taped and reeled per EIA Specification RS-468
- Laser-marked case
- Capacitance values of 0.1 μF to 330 μF
- Tolerances of $\pm 20\%$ standard, $\pm 5\%$ and $\pm 10\%$ special order
- Voltage rating of 6 – 50 VDC
- Operating temperature range of -55°C to $+125^\circ\text{C}$
- Case sizes: A, B, C, D

Applications

Typical applications include bypassing, coupling, and timing applications in computers, military ordinance, industrial, entertainment, and consumer electronic equipment.

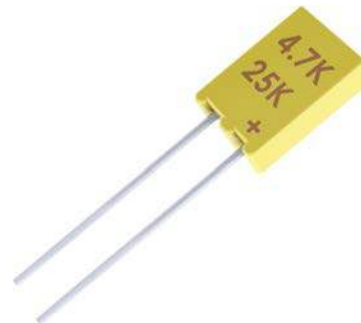

Ordering Information

T	330	B	104	M	035	A	S	
Capacitor Class	Series	Case Size	Capacitance Code (pF)	Capacitance Tolerance	Rated Voltage (VDC)	Failure Rate	Termination Finish	Packaging
T = Tantalum	Radial Lead Precision Molded Polar Solid Tantalum	A B C D	First two digits represent significant figures. Third digit specifies number of zeros to follow.	K = ±10% M = ±20% J = ±5% (available on request)	006 = 6 010 = 10 015 = 15 020 = 20 025 = 25 035 = 35 050 = 50	Not Applicable	S = Standard (steel - copper) T = 100% tin (Sn)-plated	Blank = Bulk 7301 = Tape & Reel

Performance Characteristics

Item	Performance Characteristics
Operating Temperature	-55°C to 125°C
Rated Capacitance Range	0.1 – 220 µF at 120 Hz/25°C
Capacitance Tolerance	M tolerance (20%) standard, K tolerance (10%), J tolerance (5%) special order
Rated Voltage Range	6 – 50 V
DF (120 Hz at 25°C)	Refer to Part Number Electrical Specification Table
ESR and Impedance (100 kHz at 25°C)	Refer to Part Number Electrical Specification Table (for reference only)
Leakage Current	Refer to Part Number Electrical Specification Table (at rated voltage up to +85°C and 2/3 of rated voltage applied at 125°C)

Dimensions – Millimeters (Inches)

Metric will govern

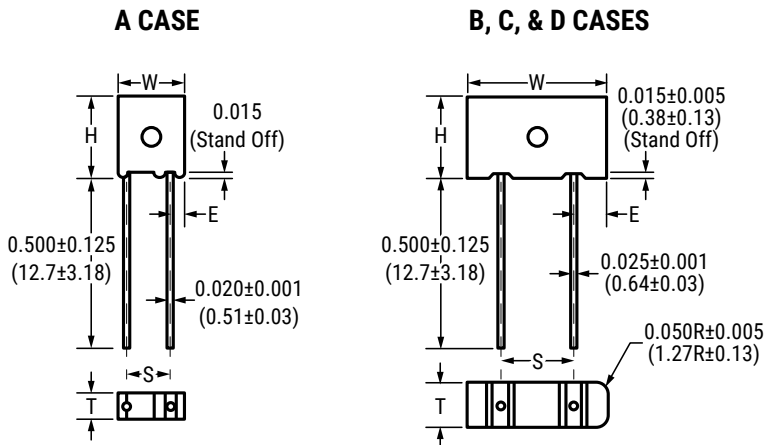

Note: On the "B" case size the stand off appears only between the two leads

Case Size	H Case Height	W Case Width	T Case Thickness	E Case to Wire	S Lead Spacing
A	0.345 ±0.008 (8.76 ±0.203)	0.230 ±0.005 (5.84 ±0.127)	0.105 ±0.005 (2.67 ±0.127)	0.050 ±0.010 (1.27 ±0.25)	0.125 ±0.005 (3.18 ±0.127)
B	0.225 ±0.015 (5.71 ±0.38)	0.285 ±0.015 (7.24 ±0.38)	0.170 ±0.015 (4.32 ±0.38)	0.042 ±0.010 (1.07 ±0.25)	0.200 ±0.005 (5.08 ±0.127)
C	0.325 ±0.015 (8.26 ±0.38)	0.325 ±0.015 (8.26 ±0.38)	0.170 ±0.015 (4.32 ±0.38)	0.062 ±0.010 (1.57 ±0.25)	0.200 ±0.005 (5.08 ±0.127)
D	0.375 ±0.015 (9.53 ±0.38)	0.600 ±0.015 (15.24 ±0.38)	0.195 ±0.015 (4.95 ±0.38)	0.200 ±0.010 (5.08 ±0.25)	0.200 ±0.005 (5.08 ±0.127)

Table 1 – Ratings & Part Number Reference

Rated Voltage	Rated Capacitance	Case Code	KEMET Part Number	DC Leakage	DF
(V) 85°C	µF		(See below for part options)	µA @ 25°C Maximum/5 Minutes	% @ 25°C 120 Hz Maximum
6	18.0	A	T330A186(1)006A(2)	1.0	6
6	22.0	A	T330A226(1)006A(2)	1.0	6
6	10.0	B	T330B106(1)006A(2)	1.0	6
6	12.0	B	T330B126(1)006A(2)	1.0	6
6	15.0	B	T330B156(1)006A(2)	1.0	6
6	18.0	B	T330B186(1)006A(2)	1.0	6
6	22.0	B	T330B226(1)006A(2)	1.0	6
6	27.0	C	T330C276(1)006A(2)	1.0	6
6	33.0	C	T330C336(1)006A(2)	1.0	6
6	39.0	C	T330C396(1)006A(2)	1.0	6
6	47.0	C	T330C476(1)006A(2)	2.0	6
6	56.0	C	T330C566(1)006A(2)	5.0	6
6	68.0	C	T330C686(1)006A(2)	5.0	6
6	82.0	D	T330D826(1)006A(2)	5.0	6
6	100.0	D	T330D107(1)006A(2)	5.0	6
6	120.0	D	T330D127(1)006A(2)	5.0	6
6	150.0	D	T330D157(1)006A(2)	5.0	6
6	180.0	D	T330D187(1)006A(2)	10.0	6
6	220.0	D	T330D227(1)006A(2)	10.0	8
10	10.0	A	T330A106(1)010A(2)	1.0	6
10	12.0	A	T330A126(1)010A(2)	1.0	6
10	15.0	A	T330A156(1)010A(2)	1.0	6
10	5.6	B	T330B565(1)010A(2)	1.0	6
10	6.8	B	T330B685(1)010A(2)	1.0	6
10	8.2	B	T330B825(1)010A(2)	1.0	6
10	10.0	B	T330B106(1)010A(2)	1.0	6
10	12.0	B	T330B126(1)010A(2)	1.0	6
10	15.0	B	T330B156(1)010A(2)	1.0	6
10	18.0	B	T330B186(1)010A(2)	1.0	6
10	22.0	B	T330B226(1)010A(2)	2.0	6
10	18.0	C	T330C186(1)010A(2)	1.0	6
10	22.0	C	T330C226(1)010A(2)	2.0	6
10	27.0	C	T330C276(1)010A(2)	2.0	6
10	33.0	C	T330C336(1)010A(2)	2.0	6
10	39.0	C	T330C396(1)010A(2)	5.0	6
10	47.0	D	T330D476(1)010A(2)	5.0	6
10	56.0	D	T330D566(1)010A(2)	5.0	6
10	68.0	D	T330D686(1)010A(2)	5.0	6
10	82.0	D	T330D826(1)010A(2)	5.0	6
10	100.0	D	T330D107(1)010A(2)	10.0	6
10	120.0	D	T330D127(1)010A(2)	10.0	6
10	150.0	D	T330D157(1)010A(2)	10.0	6
15	8.2	A	T330A825(1)015A(2)	1.0	6
15	3.9	B	T330B395(1)015A(2)	1.0	6
15	4.7	B	T330B475(1)015A(2)	1.0	6
15	5.6	B	T330B565(1)015A(2)	1.0	6
15	6.8	B	T330B685(1)015A(2)	1.0	6
15	8.2	B	T330B825(1)015A(2)	1.0	6
15	10.0	C	T330C106(1)015A(2)	1.0	6
15	12.0	C	T330C126(1)015A(2)	1.0	6
15	15.0	C	T330C156(1)015A(2)	2.0	6
15	18.0	C	T330C186(1)015A(2)	5.0	6
15	22.0	C	T330C226(1)015A(2)	5.0	6
(V) 85°C	µF		(see below for part options)	µA @ 25°C Maximum/5 Minutes	% @ 25°C 120 Hz Maximum
Rated Voltage	Rated Capacitance	Case Code	KEMET Part Number	DC Leakage	DF

(1) To complete KEMET part number, insert M for ±20%, K for ±10% or J for 5%. Designates Capacitance tolerance.

(2) To complete KEMET part number, insert T = 100% Matte Tin (Sn) Plated, S = Standard Solder coated (SnPb 5% Pb minimum).

Designates termination finish.

Higher voltage and better capacitance tolerance products may be substituted for an order within the same case size at KEMET's option.

Table 1 – Ratings & Part Number Reference cont.

Rated Voltage	Rated Capacitance	Case Code	KEMET Part Number	DC Leakage	DF
(V) 85°C	µF		(See below for part options)	µA @ 25°C Maximum/5 Minutes	% @ 25°C 120 Hz Maximum
15	27.0	C	T330C276(1)015A(2)	5.0	6
15	33.0	C	T330C336(1)015A(2)	5.0	6
15	39.0	D	T330D396(1)015A(2)	10.0	6
15	47.0	D	T330D476(1)015A(2)	10.0	6
15	56.0	D	T330D566(1)015A(2)	10.0	6
15	68.0	D	T330D686(1)015A(2)	10.0	6
15	82.0	D	T330D826(1)015A(2)	10.0	6
20	5.6	A	T330A565(1)020A(2)	1.0	6
20	6.8	A	T330A685(1)020A(2)	1.0	6
25	3.3	A	T330A335(1)025A(2)	1.0	4
25	3.9	A	T330A395(1)025A(2)	1.0	4
25	4.7	A	T330A475(1)025A(2)	1.0	4
25	2.7	B	T330B275(1)025A(2)	1.0	6
25	3.3	B	T330B335(1)025A(2)	1.0	6
25	3.9	B	T330B395(1)025A(2)	1.0	6
25	4.7	B	T330B475(1)025A(2)	1.0	6
25	5.6	C	T330C565(1)025A(2)	1.0	6
25	6.8	C	T330C685(1)025A(2)	1.0	6
25	8.2	C	T330C825(1)025A(2)	1.0	6
25	10.0	C	T330C106(1)025A(2)	1.0	6
25	12.0	C	T330C126(1)025A(2)	1.0	6
25	15.0	C	T330C156(1)025A(2)	2.0	6
25	18.0	D	T330D186(1)025A(2)	5.0	6
25	22.0	D	T330D226(1)025A(2)	5.0	6
25	27.0	D	T330D276(1)025A(2)	5.0	6
25	33.0	D	T330D336(1)025A(2)	5.0	6
25	39.0	D	T330D396(1)025A(2)	10.0	6
25	47.0	D	T330D476(1)025A(2)	10.0	6
35	0.1	A	T330A104(1)035A(2)	1.0	3
35	0.12	A	T330A124(1)035A(2)	1.0	3
35	0.15	A	T330A154(1)035A(2)	1.0	3
35	0.18	A	T330A184(1)035A(2)	1.0	3
35	0.22	A	T330A224(1)035A(2)	1.0	3
35	0.27	A	T330A274(1)035A(2)	1.0	3
35	0.33	A	T330A334(1)035A(2)	1.0	3
35	0.39	A	T330A394(1)035A(2)	1.0	3
35	0.47	A	T330A474(1)035A(2)	1.0	3
35	0.56	A	T330A564(1)035A(2)	1.0	3
35	0.68	A	T330A684(1)035A(2)	1.0	3
35	0.82	A	T330A824(1)035A(2)	1.0	3
35	1.0	A	T330A105(1)035A(2)	1.0	3
35	1.2	A	T330A125(1)035A(2)	1.0	4
35	1.5	A	T330A155(1)035A(2)	1.0	4
35	1.8	A	T330A185(1)035A(2)	1.0	4
35	2.2	A	T330A225(1)035A(2)	1.0	4
35	2.7	A	T330A275(1)035A(2)	1.0	4
35	0.10	B	T330B104(1)035A(2)	1.0	6
35	0.12	B	T330B124(1)035A(2)	1.0	6
35	0.15	B	T330B154(1)035A(2)	1.0	6
35	0.18	B	T330B184(1)035A(2)	1.0	6
35	0.22	B	T330B224(1)035A(2)	1.0	6
35	0.27	B	T330B274(1)035A(2)	1.0	6
35	0.33	B	T330B334(1)035A(2)	1.0	6
(V) 85°C	µF		(see below for part options)	µA @ 25°C Maximum/5 Minutes	% @ 25°C 120 Hz Maximum
Rated Voltage	Rated Capacitance	Case Code	KEMET Part Number	DC Leakage	DF

(1) To complete KEMET part number, insert M for ±20%, K for ±10% or J for 5%. Designates Capacitance tolerance.

(2) To complete KEMET part number, insert T = 100% Matte Tin (Sn) Plated, S = Standard Solder coated (SnPb 5% Pb minimum).

Designates termination finish.

Higher voltage and better capacitance tolerance products may be substituted for an order within the same case size at KEMET's option.

Table 1 – Ratings & Part Number Reference cont.

Rated Voltage	Rated Capacitance	Case Code	KEMET Part Number	DC Leakage	DF
(V) 85°C	µF		(See below for part options)	µA @ 25°C Maximum/5 Minutes	% @ 25°C 120 Hz Maximum
35	0.39	B	T330B394(1)035A(2)	1.0	6
35	0.47	B	T330B474(1)035A(2)	1.0	6
35	0.56	B	T330B564(1)035A(2)	1.0	6
35	0.68	B	T330B684(1)035A(2)	1.0	6
35	0.82	B	T330B824(1)035A(2)	1.0	6
35	1.0	B	T330B105(1)035A(2)	1.0	6
35	1.2	B	T330B125(1)035A(2)	1.0	6
35	1.5	B	T330B155(1)035A(2)	1.0	6
35	1.8	B	T330B185(1)035A(2)	1.0	6
35	2.2	B	T330B225(1)035A(2)	1.0	6
35	2.7	B	T330B275(1)035A(2)	1.0	6
35	3.3	B	T330B335(1)035A(2)	1.0	6
35	3.9	C	T330C395(1)035A(2)	1.0	6
35	4.7	C	T330C475(1)035A(2)	1.0	6
35	5.6	C	T330C565(1)035A(2)	1.0	6
35	6.8	C	T330C685(1)035A(2)	2.0	6
35	8.2	C	T330C825(1)035A(2)	5.0	6
35	10.0	C	T330C106(1)035A(2)	5.0	6
35	12.0	D	T330D126(1)035A(2)	5.0	6
35	15.0	D	T330D156(1)035A(2)	5.0	6
35	18.0	D	T330D186(1)035A(2)	10.0	6
35	22.0	D	T330D226(1)035A(2)	10.0	6
35	27.0	D	T330D276(1)035A(2)	10.0	6
35	33.0	D	T330D336(1)035A(2)	10.0	6
50	0.10	A	T330A104(1)050A(2)	1.0	3
50	0.12	A	T330A124(1)050A(2)	1.0	3
50	0.15	A	T330A154(1)050A(2)	1.0	3
50	0.18	A	T330A184(1)050A(2)	1.0	3
50	0.22	A	T330A224(1)050A(2)	1.0	3
50	0.27	A	T330A274(1)050A(2)	1.0	3
50	0.33	A	T330A334(1)050A(2)	1.0	3
50	0.39	A	T330A394(1)050A(2)	1.0	3
50	0.47	A	T330A474(1)050A(2)	1.0	3
50	0.56	A	T330A564(1)050A(2)	1.0	3
50	0.68	A	T330A684(1)050A(2)	1.0	3
50	0.82	A	T330A824(1)050A(2)	1.0	4
50	1.0	A	T330A105(1)050A(2)	1.0	4
50	1.2	A	T330A125(1)050A(2)	1.0	4
50	1.5	A	T330A155(1)050A(2)	1.0	4
50	0.10	B	T330B104(1)050A(2)	1.0	6
50	0.12	B	T330B124(1)050A(2)	1.0	6
50	0.15	B	T330B154(1)050A(2)	1.0	6
50	0.18	B	T330B184(1)050A(2)	1.0	6
50	0.22	B	T330B224(1)050A(2)	1.0	6
50	0.27	B	T330B274(1)050A(2)	1.0	6
50	0.33	B	T330B334(1)050A(2)	1.0	6
50	0.39	B	T330B394(1)050A(2)	1.0	6
50	0.47	B	T330B474(1)050A(2)	1.0	6
50	0.56	B	T330B564(1)050A(2)	1.0	6
50	0.68	B	T330B684(1)050A(2)	1.0	6
50	0.82	B	T330B824(1)050A(2)	1.0	6
50	1.0	B	T330B105(1)050A(2)	1.0	6
50	1.2	B	T330B125(1)050A(2)	1.0	6
(V) 85°C	µF		(see below for part options)	µA @ 25°C Maximum/5 Minutes	% @ 25°C 120 Hz Maximum
Rated Voltage	Rated Capacitance	Case Code	KEMET Part Number	DC Leakage	DF

(1) To complete KEMET part number, insert M for ±20%, K for ±10% or J for 5%. Designates Capacitance tolerance.

(2) To complete KEMET part number, insert T = 100% Matte Tin (Sn) Plated, S = Standard Solder coated (SnPb 5% Pb minimum).

Designates termination finish.

Higher voltage and better capacitance tolerance products may be substituted for an order within the same case size at KEMET's option.

Table 1 – Ratings & Part Number Reference cont.

Rated Voltage	Rated Capacitance	Case Code	KEMET Part Number	DC Leakage	DF
(V) 85°C	µF		(See below for part options)	µA @ 25°C Maximum/5 Minutes	% @ 25°C 120 Hz Maximum
50	1.5	B	T330B155(1)050A(2)	1.0	6
50	1.8	B	T330B185(1)050A(2)	1.0	6
50	2.2	B	T330B225(1)050A(2)	1.0	6
50	2.7	C	T330C275(1)050A(2)	1.0	6
50	3.3	C	T330C335(1)050A(2)	2.0	6
50	3.9	C	T330C395(1)050A(2)	5.0	6
50	4.7	C	T330C475(1)050A(2)	5.0	6
50	5.6	C	T330C565(1)050A(2)	5.0	6
50	6.8	D	T330D685(1)050A(2)	5.0	6
50	8.2	D	T330D825(1)050A(2)	5.0	6
50	10.0	D	T330D106(1)050A(2)	5.0	6
50	12.0	D	T330D126(1)050A(2)	5.0	6
50	15.0	D	T330D156(1)050A(2)	10.0	6
50	18.0	D	T330D186(1)050A(2)	10.0	6
(V) 85°C	µF		(see below for part options)	µA @ 25°C Maximum/5 Minutes	% @ 25°C 120 Hz Maximum
Rated Voltage	Rated Capacitance	Case Code	KEMET Part Number	DC Leakage	DF

(1) To complete KEMET part number, insert M for ±20%, K for ±10% or J for 5%. Designates Capacitance tolerance.

(2) To complete KEMET part number, insert T = 100% Matte Tin (Sn) Plated, S = Standard Solder coated (SnPb 5% Pb minimum).

Designates termination finish.

Higher voltage and better capacitance tolerance products may be substituted for an order within the same case size at KEMET's option.

Recommended Voltage Derating Guidelines

	-55°C to 85°C	85°C to 105°C
% Change in working DC voltage with temperature	V_R	66% of V_R

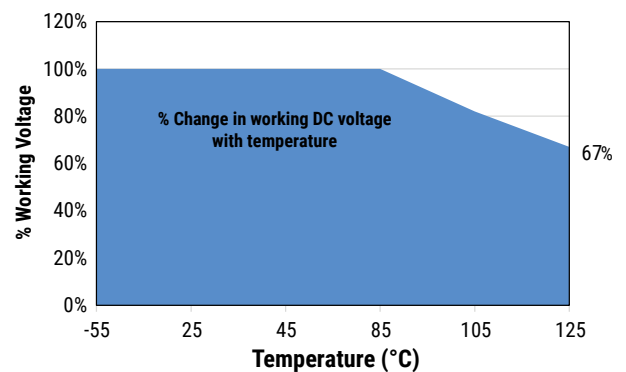

Ripple Current/Ripple Voltage

Permissible AC ripple voltage and current are related to equivalent series resistance (ESR) and the power dissipation capabilities of the device. Permissible AC ripple voltage that may be applied is limited by following criteria:

1. Dissipated power must not exceed the limits specified for the Series.
2. The positive peak AC voltage plus the DC bias voltage, if any, must not exceed the DC voltage rating of the capacitor.
3. The negative peak AC voltage in combination with bias voltage, if any, must not exceed the allowable limits specified for reverse voltage.

Thermal capacities for the various case sizes have been determined empirically and are listed below. The “ripple voltage” permissible may be calculated from the impedance and ESR data shown in the respective product section.

Temperature Compensation Multipliers for Maximum Power Dissipation		
$T \leq 25^{\circ}\text{C}$	$T \leq 85^{\circ}\text{C}$	$T \leq 125^{\circ}\text{C}$
1.00	0.90	0.40

T = Environmental Temperature

Maximum allowable rms ripple voltage or current may be determined as follows:

$$I(max) = \sqrt{P_{max}/R}$$

$$E(max) = \sqrt{P_{max}/R}$$

I = rms ripple current (amperes)

E = rms ripple voltage (volts)

P_{max} = Maximum power dissipation (watts)

R = ESR at specified frequency (ohms)

Case Size	Maximum Power Dissipation (Pmax) Watts at 25°C
A	0.09
B	0.09
C	0.100
D/F	0.125

Optimum Solder Wave Profile

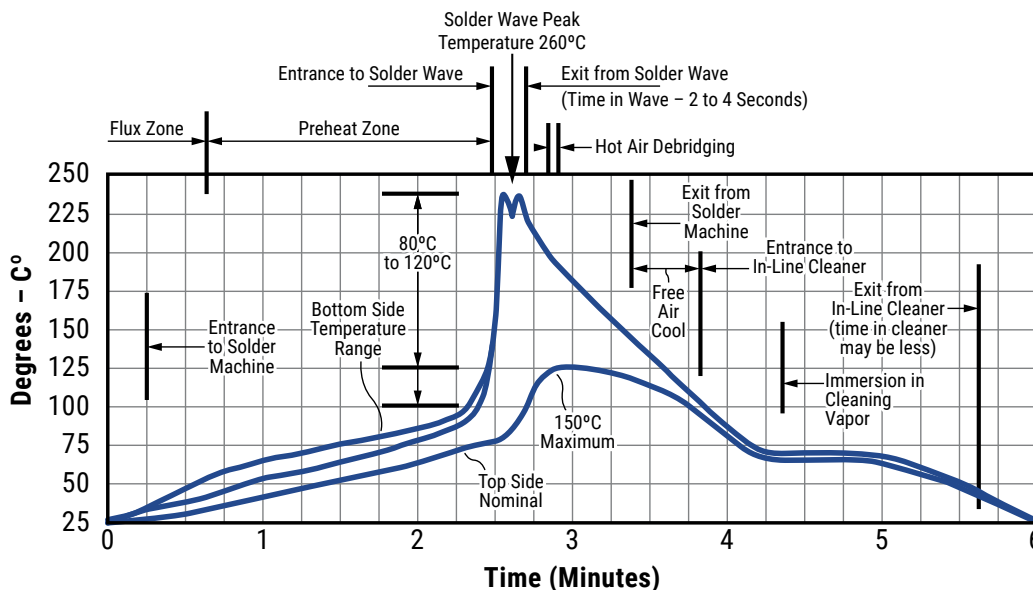

Reverse Voltage

Although these are polar capacitors, some degree of transient voltage reversal is permissible, as seen below. The capacitors should not be operated continuously in reverse mode, even within these limits.

Temperature	Percentage of Rated Voltage
+25°C	15
+85°C	5
+125°C	1

Mounting

All encased capacitors will pass the Resistance to Soldering Heat Test of MIL-STD-202, Method 210, Condition C. This test simulates wave solder of topside board mount product. This demonstration of resistance to solder heat is in accordance with what is believed to be the industry standard. More severe treatment must be considered reflective of an improper soldering process. The above figure is a recommended solder wave profile for both axial and radial leaded solid tantalum capacitors.

Capacitor Marking

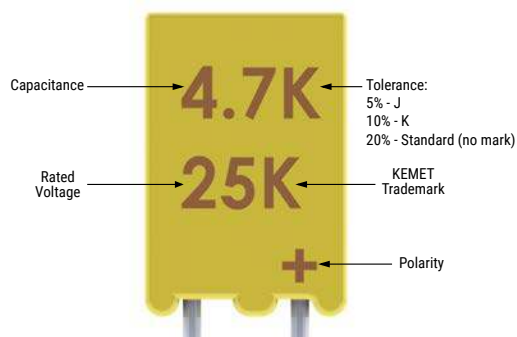

Storage

Tantalum molded radial/axial capacitors should be stored in normal working environments. KEMET recommends that maximum storage temperature not exceed 40°C and maximum storage humidity not exceed 60% RH. Storage at high temperature may cause a small, temporary increase in leakage current (measured under standard conditions), but the original value is usually restored within a few minutes after application of rated voltage. Storage at high humidity may increase capacitance and dissipation factor. Solderability will be degraded by exposure to high temperatures, high humidity, corrosive atmospheres, and long term storage. For optimized solderability capacitors stock should be used promptly, preferably within three years of receipt.

Tape & Reel Packaging Information

KEMET offers solid tantalum capacitors fully compatible for use with automatic insertion machines for radial-lead components. Aris Reeling meets all requirements of EIA Standard RS-468. KEMET capacitors are wound on a precision made ARIS Reel Package. ARIS Ammo Package is also available.

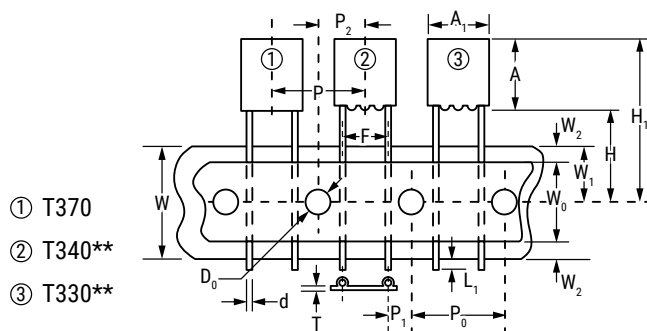

Dimension	Symbol	Nominal mm (inch)		Tolerance mm (inch)	
Body Height (1)	A	10.50 (0.413)		±0.38 (±0.015) Maximum	
Body Width (1)	A ₁	15.24 (0.600)		±0.38 (±0.015) Maximum	
Sprocket Hole Diameter	D ₀	4.0 (0.157)		±0.3 (±0.012)	
Lead Diameter	d	0.51 (0.020)	0.64 (0.025)	±0.05 (±0.001)	±0.03
Lead Center (5)	F	5.0 (0.197)	2.5 (0.098)	+0.8 (+0.032)	-0.2 (-0.008)
Component Base to Tape Center (2) (4) (6)	H	16.0 – 21.0 (0.630 – 0.827)		Reference Only	
Lead Standoff Height	H ₀	N/A			
Component Height Above Tape Center	H ₁	32.25 (1.270)		Maximum	
Component Alignment Front to Rear	ΔH	0		±2.0 (±0.079)	
Cut Out Length	L	11.0 (0.433)		Maximum	
Lead Protrusion	L ₁	2.0 (0.079)		Maximum	
Component Pitch (5)	P	12.7 (0.500)		±1.0 (±0.039)	
Sprocket Hole Pitch (3)	P ₀	12.7 (0.500)		±0.03 (±0.012)	
Sprocket Hole Center to Lead Center (4) (5)	P ₁	3.85 (0.152)	4.76 (0.188)	5.1 (0.201)	±0.7 (±0.028)
Sprocket Hole Center to Component Center	P ₂	6.35 (0.250)		±1.31 (±0.051)	
Body Thickness	T ₀	6.35 (0.250)		±1.3 Maximum	
Total Tape Thickness	T	0.7 (0.28)		±0.02(±0.008)	
Carrier Tape Width	W	18.0 (0.709)		+1.0/-0.5 (+0.039/-0.020)	
Hold-Down Tape Width	W ₀	15 (0.561)	6 (0.236)	+1.0/-0.8 (+0.039/-0.031)	
Sprocket Hole Location	W ₁	9.0 (0.354)		+0.075/-0.5 (+0.030/-0.020)	
Hold-Down Tape Location	W ₂	3.0 (0.118)	12.0 (0.472)	Maximum	

Notes:

(1) See Dimensions table for specific values per case size.

(2) Reference only.

(3) Cumulative pitch error ±1.0 mm (0.039") maximum in 20 consecutive sprocket hole locations.

(4) Measured at bottom of standoff.

(5) P, P₁ and F measured at egress from carrier tape.

(6) H dimensions for T370 D and E 16.5mm ±0.5mm (0.650" ±0.020")

On polar devices, the positive (+) lead exits from container first.

* Lead spacings are 2.5 mm (0.098") center-to-center.

** Lead spacings are 5.0 mm (0.197") center-to-center.

Table 2 – Packaging Quantity

Case Size	Standard Bulk Quantity	Standard Reel Quantity	Reel C-Spec	Ammo Pack Quantity
A	400	1,000	C-7301	1,600
B	300	1,000	C-7301	1,200
C	200	1,000	C-7301	1,200
D	100	N/A	N/A	N/A

KEMET Electronics Corporation Sales Offices

For a complete list of our global sales offices, please visit www.kemet.com/sales.

Disclaimer

All product specifications, statements, information and data (collectively, the "Information") in this datasheet are subject to change. The customer is responsible for checking and verifying the extent to which the Information contained in this publication is applicable to an order at the time the order is placed. All Information given herein is believed to be accurate and reliable, but it is presented without guarantee, warranty, or responsibility of any kind, expressed or implied.

Statements of suitability for certain applications are based on KEMET Electronics Corporation's ("KEMET") knowledge of typical operating conditions for such applications, but are not intended to constitute – and KEMET specifically disclaims – any warranty concerning suitability for a specific customer application or use. The Information is intended for use only by customers who have the requisite experience and capability to determine the correct products for their application. Any technical advice inferred from this Information or otherwise provided by KEMET with reference to the use of KEMET's products is given gratis, and KEMET assumes no obligation or liability for the advice given or results obtained.

Although KEMET designs and manufactures its products to the most stringent quality and safety standards, given the current state of the art, isolated component failures may still occur. Accordingly, customer applications which require a high degree of reliability or safety should employ suitable designs or other safeguards (such as installation of protective circuitry or redundancies) in order to ensure that the failure of an electrical component does not result in a risk of personal injury or property damage.

Although all product-related warnings, cautions and notes must be observed, the customer should not assume that all safety measures are indicated or that other measures may not be required.

KEMET is a registered trademark of KEMET Electronics Corporation.