

Dot Graphic VFD Module

GU128X32-800A

- ❑ 128 x 32 Dot Graphic
- ❑ Operating Temp -40°C to +85°C
- ❑ Single 5V Supply.
- ❑ High Brightness Blue Green Display
- ❑ Selectable Parallel (i80/M68)/Serial Interface
- ❑ Twin Screen Graphic RAM
- ❑ 16 Level Brightness Control Function

The module includes the Vacuum Fluorescent Display glass, driver and control ASIC, with integral refresh Graphic RAM and logic for parallel and synchronous serial interfaces. The high speed 8 bit parallel interface is 5V CMOS compatible suitable for connection to a host CPU bus. Brightness control and power down functions are provided. A full data sheet is available.

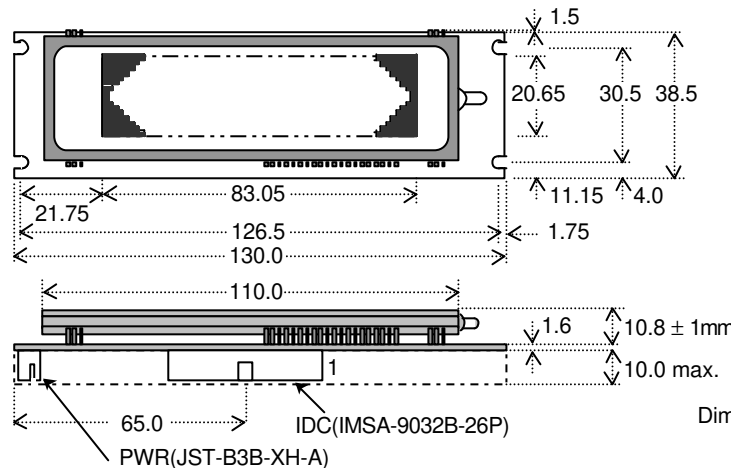

Dimensions in mm & subject to tolerances. Mounting holes 3.5mm dia.

ELECTRICAL SPECIFICATION

Parameter	Symbol	Value	Condition
Power Supply Voltage	V _{CC}	5.0VDC +/- 5%	GND=0V
Power Supply Current	I _{CC}	450mADC typ.	V _{CC} =5V
Logic High Input	V _{IH}	4.0 VDC min.	I _{IH} = 2uA
Logic Low Input	V _{IL}	1.0 VDC max.	I _{IL} = -600uA
Logic High Output	V _{OH}	4.7 VDC min.	I _{OH} = -300uA
Logic Low Output	V _{OL}	0.3 VDC max.	I _{OL} = 300uA
Reset Input Voltage	V _{RH}	4.0 VDC min.	I _{RH} = 5uA
Reset Input Voltage	V _{RL}	0.6 VDC max.	I _{RL} = -600uA

The power on rise time should be less than 100ms. The inrush current at power on can be 2 x I_{CC}.

OPTICAL and ENVIRONMENTAL SPECIFICATIONS

Parameter	Value
Display Area (XxY mm)	83.05 x 20.65
Dot Size/Pitch (XxY mm)	0.5 x 0.5/0.65 x 0.65
Luminance	350 cd/m ² Min.
Colour of Illumination	Blue-Green (Filter for colours)
Operating Temperature	-40°C to +85°C
Storage Temperature	-40°C to +85°C
Operating Humidity (non condensing)	20 to 80% RH @ 25°C

SOFTWARE COMMANDS

Instruction	C/D	Instruction Byte	No. Bytes
Set Display On/Off / Layer Merge	1	20H-2FH	2
Set Display Brightness	1	40H-4FH	1
Clear Display	1	52H-5FH	1
Set Cursor XY Address	1	60H-67H	3
Set Display Start X Address	1	70H-7FH	2
Set Write Address Mode	1	80H-8FH	1
Scroll Display Vertically Up/Down	1	B0H-BFH	1
Read Cursor XY Address	1	D4H-D7H	3
Write Data	0	00H-FFH	1

TIMING PARAMETERS (min)

i80/M68 Parameters	Time	Serial Parameters	Time
Write /WR/EN Cycle Time	400ns	SCK Cycle Time	200ns
Write /WR/EN Pulse Width	100ns	SCK Pulse Width	80ns
Set Up To Write /WR/EN	30ns	Set Up To SCK, /CSS=L	40ns
Hold after Write /WR/EN	20ns	Delay After 8 th bit, /CSS=H	150ns

SCROLLING GRAPHIC DISPLAY

The pattern in GRAM can be scrolled around the display. Horizontal scroll is achieved by increment/decrement of the Display Start X Address. The vertical scroll process considers layer 0, then layer 1 as a continuous 128 bit high vertical area within RAM.

BLOCK DIAGRAM

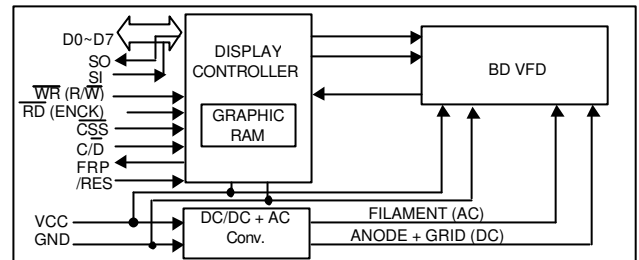

GRAPHIC RAM

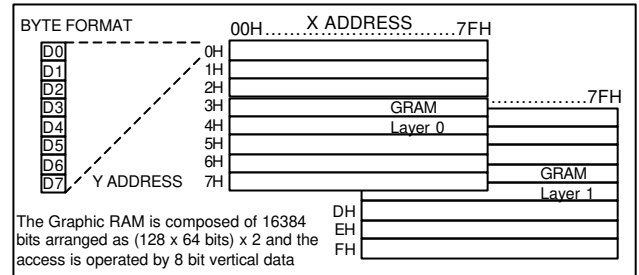

IDC DATA CONNECTOR

Pin	i80	M68	Serial	Pin	Sig
1	D7	D7	X	2	GND
3	D6	D6	X	4	GND
5	D5	D5	X	6	GND
7	D4	D4	X	8	GND
9	D3	D3	X	10	GND
11	D2	D2	X	12	GND
13	D1	D1	SO	14	GND
15	D0	D0	SI	16	GND
17	/WR	/R/WR	X	18	GND
19	C/D	C/D	C/D	20	GND
21	/RD	/ENCK	SCK	22	GND
23	/CSS	/CSS	/CSS	24	GND
25	FRP	FRP	FRP	26	/RES

3 PIN POWER CONNECTOR

Pin	Sig
1	Vcc
2	Test (Factory only)
3	GND

PCB JUMPERS (O)pen (L)ink

Interface	J1	J2
Serial	L	O / L
i80 Parallel	O	O
M68 Parallel	O	L

CONTACT

Noritake Sales Office Tel Nos
 Nagoya Japan: +81 (0)52-561-9867
 Canada: +1-416-291-2946
 Chicago USA: +1-847-439-9020
 Munchen (D): +49 (0)89-3214-290
 Itron UK: +44 (0)1493 601144
 Rest Europe: +49 (0)61-0520-9220
www.noritake-iron.com

Subject to change without notice.
 IUK Doc Ref: 03471 Iss:1 23/07/01