

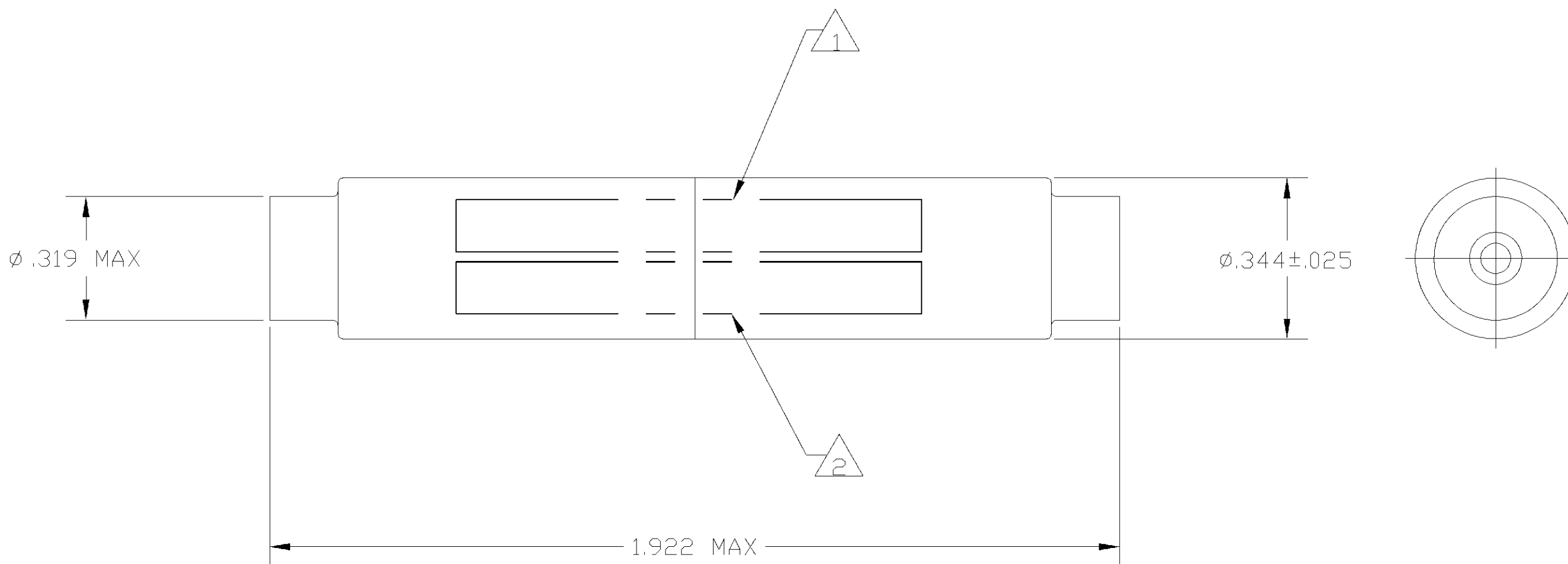







THIS DRAWING IS UNPUBLISHED. RELEASED FOR PUBLICATION
 © COPYRIGHT BY TYCO ELECTRONICS CORPORATION. ALL RIGHTS RESERVED.

LDC		DIST		REVISIONS			
P	LTR	DESCRIPTION	DATE	DWN	APVD		
B		REV PER OG3D-0083-01	07NOV01	MB	DM		

DESCRIPTION	MATERIAL	FINISH
GROMMET	FLUOROSILICONE 40/50 BLEND PER MIL-R-25988	COLOR: BLUE
SPLICE ASSEMBLY HOUSING	EPOXY	COLOR: BLACK
CONTACT FEMALE SOCKET	BERYLLIUM COPPER PER QQ-C-533	GOLD PLATE PER MIL-G-45204
CLIP CONTACT RETAINING	BERYLLIUM COPPER PER QQ-C-533 OR STAINLESS STEEL PER QQ-S-766	NONE
TUBE SHRINK	PER MIL-1-23053/8	COLOR TRANSPARENT
CONTACTS 	COPPER ALLOY PER QQ-B-750	GOLD PLATE PER MIL-G-45204



-  A QUANTITY OF 2 CONTACTS ARE SUPPLIED WITH WIRE SPLICE.
-  PART NO. 592583-4 IS MARKED WITH MILITARY PART NO. M81714/11-22D. .060 MINIMUM HIGH CHARACTERS AT APPROXIMATE AREA SHOWN.
-  PART NO. 592583-3 IS MARKED WITH MILITARY PART NO. M81714/11-20D. .060 MINIMUM HIGH CHARACTERS AT APPROXIMATE AREA SHOWN.
-  PART NO. 592583-2 IS MARKED WITH MILITARY PART NO. M81714/11-16D. .060 MINIMUM HIGH CHARACTERS AT APPROXIMATE AREA SHOWN.
-  PART NO. 592583-1 IS MARKED WITH MILITARY PART NO. M81714/11-12D. .060 MINIMUM HIGH CHARACTERS AT APPROXIMATE AREA SHOWN.
-  MARK WIRE SPLICE WITH "AMP", AMP PART NO. AND DATE CODE .060 MINIMUM HIGH CHARACTERS AT APPROXIMATE AREA SHOWN.

REMARKS	DESCRIPTION	PART NO.
	SIZE 20/22	592583-7
—	SIZE 20/22	592583-6
—	SIZE 16	592583-5
SUPERSEDED BY -7	SIZE 20/22	592583-4
	SIZE 20/22	592583-3
	SIZE 16	592583-2
	SIZE 12	592583-1

THIS DRAWING IS A CONTROLLED DOCUMENT.		DWN J. MECK 04-10-93	AMP Tyco Electronics Corporation Harrisburg, PA 17105	
DIMENSIONS: INCHES		CHK R. RYAN 05-12-93		
TOLERANCES UNLESS OTHERWISE SPECIFIED:		APVD R. RYAN 05-12-93	NAME WIRE SPLICE, SINGLE SIZE 12, 20/22 ASSEMBLY TJ	
0 PLC ± - 1 PLC ± - 2 PLC ± .02 3 PLC ± - 4 PLC ± - ANGLES ± -		PRODUCT SPEC —	SIZE A2	
MATERIAL —		APPLICATION SPEC —	CAGE CODE 00779	DRAWING NO C-592583
FINISH —		WEIGHT —	RESTRICTED TO —	SCALE 4:1
CUSTOMER DRAWING			SHEET 1 OF 3	REV B

THIS DRAWING IS UNPUBLISHED. RELEASED FOR PUBLICATION
 © COPYRIGHT BY TYCO ELECTRONICS CORPORATION. ALL RIGHTS RESERVED.

LDC		DIST		REVISIONS			
DF	AD	P	LTR	DESCRIPTION	DATE	DWN	APVD
		-		SEE SHEET 1	-	-	-

DESCRIPTION	MATERIAL	FINISH
GROMMET	FLUOROSILICONE 40/50 BLEND PER MIL-R-25988	COLOR: BLUE
SPLICE ASSEMBLY HOUSING	EPOXY	COLOR: BLACK
CONTACT FEMALE SOCKET	BERYLLIUM COPPER PER QQ-C-533	GOLD PLATE PER MIL-G-45204
CLIP CONTACT RETAINING	BERYLLIUM COPPER PER QQ-C-533 OR STAINLESS STEEL PER QQ-S-766	NONE
TUBE SHRINK	PER MIL-1-23053/8	COLOR TRANSPARENT
CONTACTS 	COPPER ALLOY PER QQ-B-750	GOLD PLATE PER MIL-G-45204

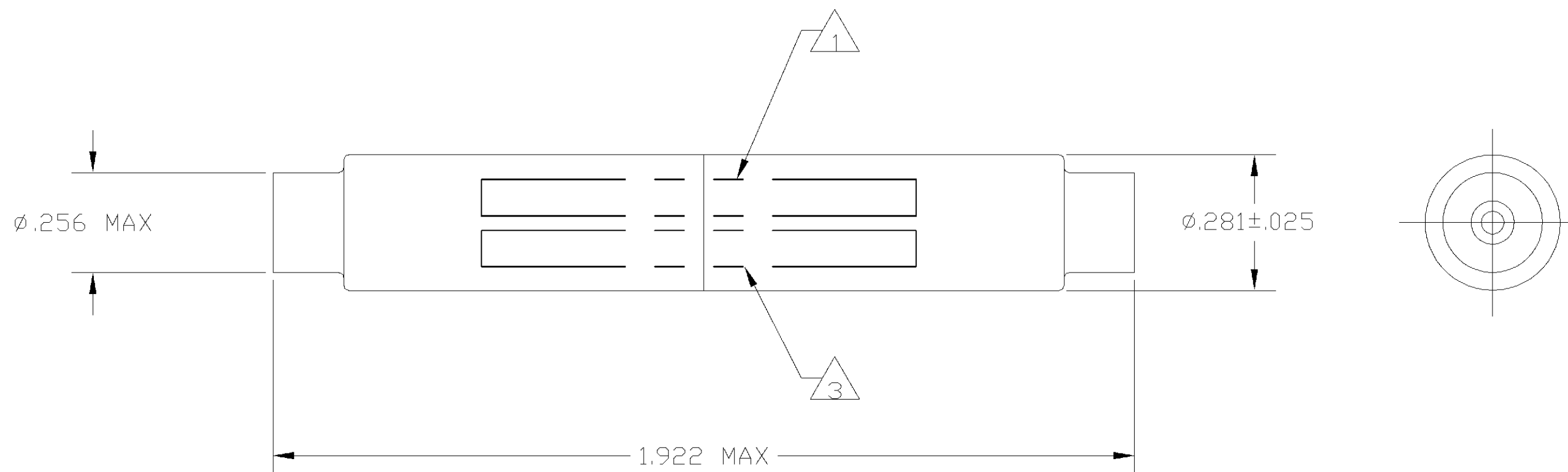

THIS DRAWING IS A CONTROLLED DOCUMENT.		DWN J. MECK 04-10-93	 Tyco Electronics Corporation Harrisburg, PA 17105																			
DIMENSIONS: INCHES		CHK R. RYAN 05-12-93																				
TOLERANCES UNLESS OTHERWISE SPECIFIED:		APVD R. RYAN 05-12-93	NAME WIRE SPLICE, SINGLE SIZE 12, 20/22 ASSEMBLY TJ																			
<table border="1"> <tr><td>0 PLC</td><td>±</td><td>-</td></tr> <tr><td>1 PLC</td><td>±</td><td>-</td></tr> <tr><td>2 PLC</td><td>±</td><td>.02</td></tr> <tr><td>3 PLC</td><td>±</td><td>-</td></tr> <tr><td>4 PLC</td><td>±</td><td>-</td></tr> <tr><td>ANGLES</td><td>±</td><td>-</td></tr> </table>		0 PLC	±	-	1 PLC	±	-	2 PLC	±	.02	3 PLC	±	-	4 PLC	±	-	ANGLES	±	-	PRODUCT SPEC -	SIZE A2	CAGE CODE 00779
0 PLC	±	-																				
1 PLC	±	-																				
2 PLC	±	.02																				
3 PLC	±	-																				
4 PLC	±	-																				
ANGLES	±	-																				
MATERIAL		FINISH	DRAWING NO C-592583	RESTRICTED TO -																		
-		-	CUSTOMER DRAWING																			
		WEIGHT -	SCALE 4: 1	SHEET 2 OF 3																		
			REV B																			

THIS DRAWING IS UNPUBLISHED. RELEASED FOR PUBLICATION
 © COPYRIGHT BY TYCO ELECTRONICS CORPORATION. ALL RIGHTS RESERVED.

LDC		DIST		REVISIONS			
P	LTR	DESCRIPTION	DATE	DWN	APVD		
-	-	SEE SHEET 1	-	-	-		

DESCRIPTION	MATERIAL	FINISH
GROMMET	FLUOROSILICONE 40/50 BLEND PER MIL-R-25988	COLOR: BLUE
SPLICE ASSEMBLY HOUSING	EPOXY	COLOR: BLACK
CONTACT FEMALE SOCKET	BERYLLIUM COPPER PER QQ-C-533	GOLD PLATE PER MIL-G-45204
CLIP CONTACT RETAINING	BERYLLIUM COPPER PER QQ-C-533 OR STAINLESS STEEL PER QQ-S-766	NONE
TUBE SHRINK	PER MIL-1-23053/8	COLOR TRANSPARENT
CONTACTS 	COPPER ALLOY PER QQ-B-750	GOLD PLATE PER MIL-G-45204

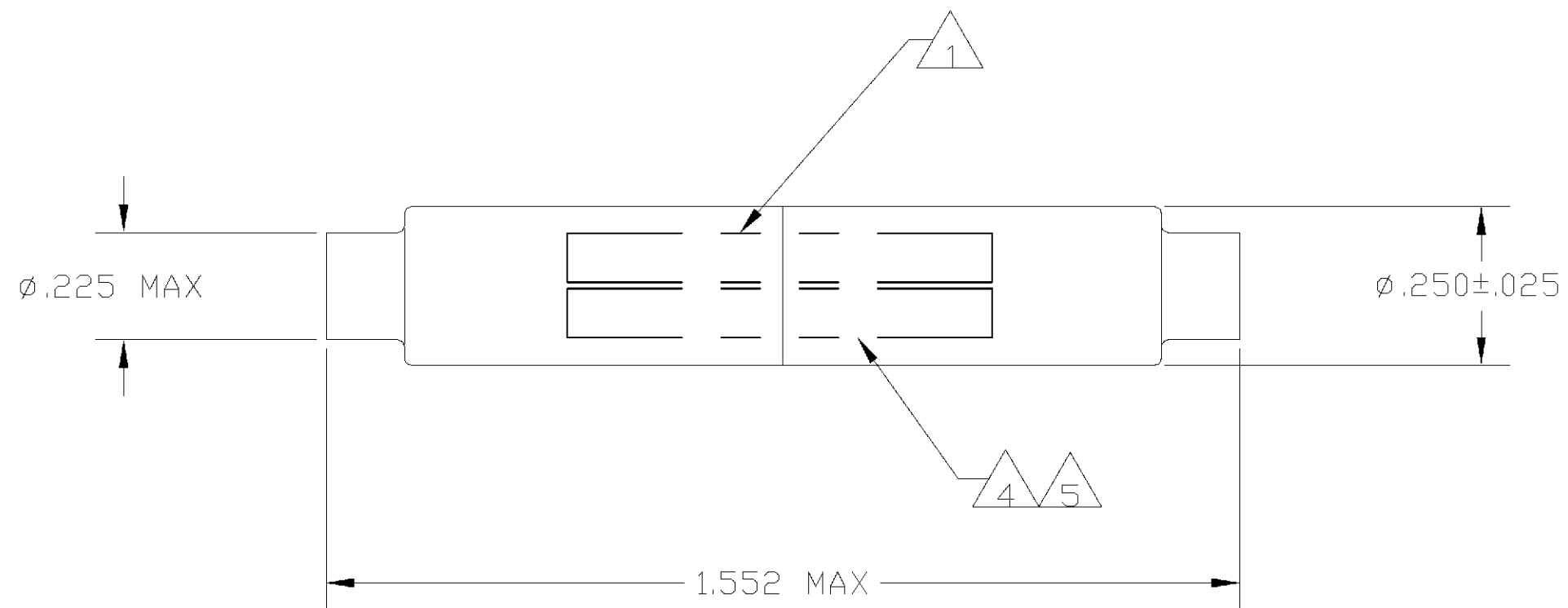

THIS DRAWING IS A CONTROLLED DOCUMENT.		DWN J. MECK 04-10-93	AMP Tyco Electronics Corporation Harrisburg, PA 17105	
DIMENSIONS: INCHES		CHK R. RYAN 05-12-93	NAME WIRE SPLICE, SINGLE SIZE 12, 20/22 ASSEMBLY TJ	
TOLERANCES UNLESS OTHERWISE SPECIFIED:		APVD R. RYAN 05-12-93	SIZE A2	CAGE CODE 00779
0 PLC ± -	1 PLC ± -	PRODUCT SPEC -	DRAWING NO C-592583	RESTRICTED TO -
2 PLC ± .02	3 PLC ± -	APPLICATION SPEC -	SCALE 4: 1	SHEET 3 OF 3
4 PLC ± -	ANGLES ± -	WEIGHT -	CUSTOMER DRAWING	REV B
MATERIAL -	FINISH -			