

HFX6015-XXX

FOR INDUSTRIAL BUS SYSTEMS

FEATURES

- Super bright LED for optical fiber communication
- High accuracy by use of special plastic package with centered LED die
- High output at suitable peak wavelength (typ.) for plastic fiber
- High frequency cut-off, most suited for high speed data transmissions ($f_c = \text{typ. } 7 \text{ MHz}$)
- HFX6015-200: Metal barrel for high mechanical stability
- HFX6015-200: Separate grounding of barrel for optimum EMI/RFI shielding

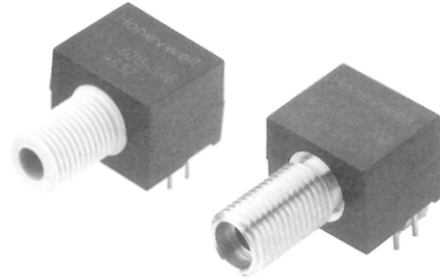

opho_234.TIF

OUTLINE DIMENSIONS in inches (mm)

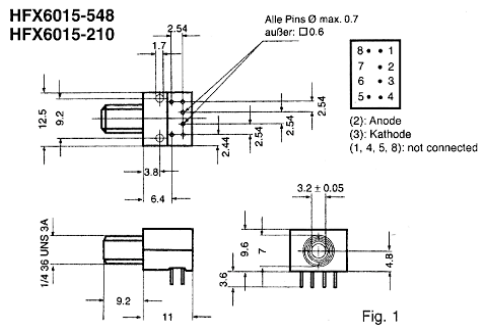

ODIM_232.TIF

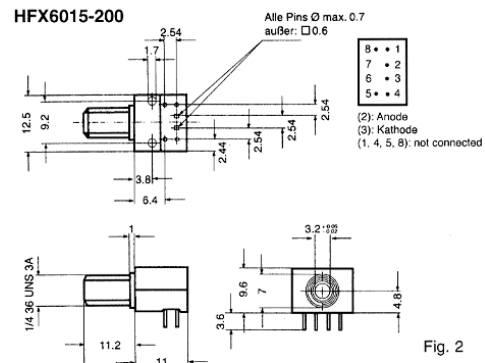

OGRA-166.TIF

HFX6015-XXX

FOR INDUSTRIAL BUS SYSTEMS

ELECTRO-OPTICAL CHARACTERISTICS

PARAMETER	SYMBOL	MIN	TYP	MAX	UNITS	TEST CONDITIONS
Peak Wavelength	λ_p		660		nm	$I_F = 30 \text{ mA}^{(1)}$
Spectral Line Half Width	$\Delta\lambda$		30		nm	$I_F = 30 \text{ mA}^{(1)}$
Forward Voltage	V_F		2.5		V	$I_F = 30 \text{ mA}^{(1)}$
Reverse Current	I_R		4		μA	$V_R = 4 \text{ V}$
Capacitance	C_o		50		pF	
Response Time	t_r, t_f		50		ns	$I_F = 30 \text{ mA}^{(1)}$

Note

1. Derate Linearly from 25°C: 0.93 mA/°C

HFX6015-200 (FIG.2) SERCOS

PARAMETER	SYMBOL	MIN	TYP	MAX	UNITS	TEST CONDITIONS
Coupled Power	P_C	300			μw	$I_F = 30 \text{ mA}^{(1)}$ 1 mm fibre

HFX6015-210 (FIG.1) GENERAL PURPOSE BUS APPLICATIONS

PARAMETER	SYMBOL	MIN	TYP	MAX	UNITS	TEST CONDITIONS
Coupled Power	P_C	300			μw	$I_F = 30 \text{ mA}^{(1)}$ 1 mm fibre

HFX6015-4XX PROFIBUS

PARAMETER	SYMBOL	MIN	TYP	MAX	UNITS	TEST CONDITIONS
Coupled Power	P_C	-5.5			dBm	1 mm fibre

HFX6015-4XX PROFIBUS

PARAMETER	SYMBOL	MIN	TYP	MAX	UNITS	TEST CONDITIONS
Coupled Power	P_C	400		1100	μw	$I_F = 4 \text{ mA}$

ABSOLUTE MAXIMUM RATINGS

(25°C Free-Air Temperature unless otherwise noted)

Forward current	70 mA
Peak forward current	300 mA
Reverse voltage	+4 V
Power dissipation	140 mW
Operating temperature	-30 to +85°C
Storage temperature	260°C, 5 sec (3,0 mm from body)

OGRA_166.TIF

Honeywell reserves the right to make changes in order to improve design and supply the best products possible.

Honeywell

121

HFX6015-XXX

FOR INDUSTRIAL BUS SYSTEMS

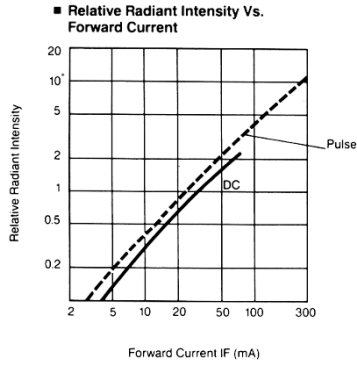

OGRA_152.TIF

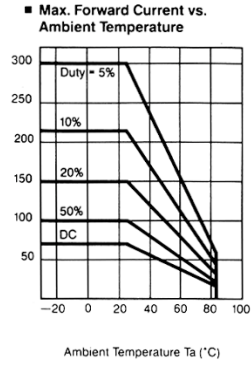

OGRA_153.TIF

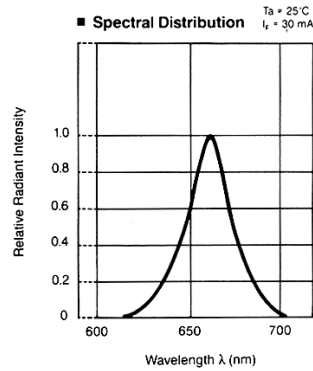

OGRA_154.TIF

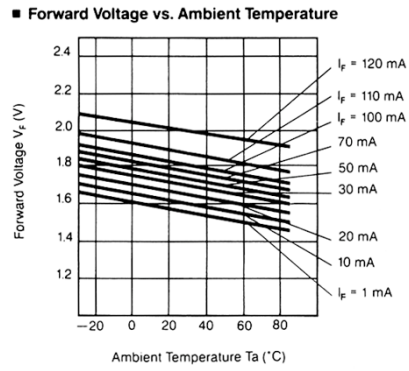

OGRA_155.TIF

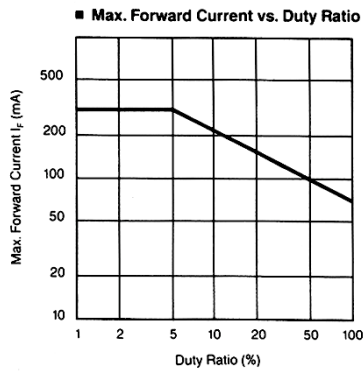

OGRA_156.TIF

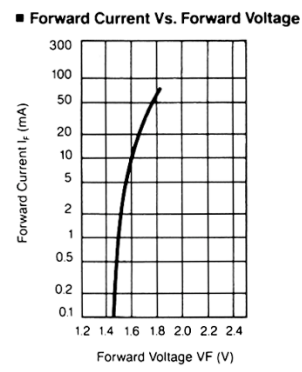

OGRA_157.TIF