

MATERIAL NUMBER	COLOR
194370029	BLACK
194370060	GREEN
194370061	GRAY

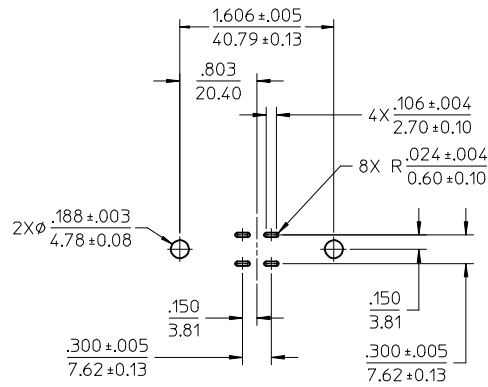

RECOMMENDED PCB LAYOUT
COMPONENT SIDE
TOLERANCES ARE NON-CUMULATIVE

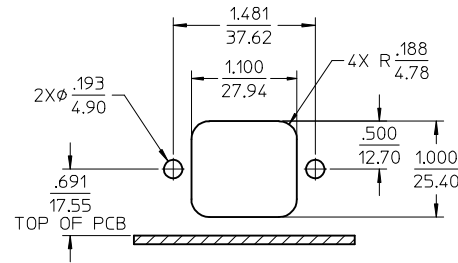

RECOMMENDED PANEL MOUNT OPENING
MAX. PANEL THK .093/2.362

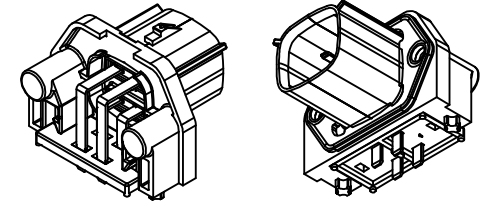

ASSEMBLED VIEW
SCALE 1:1

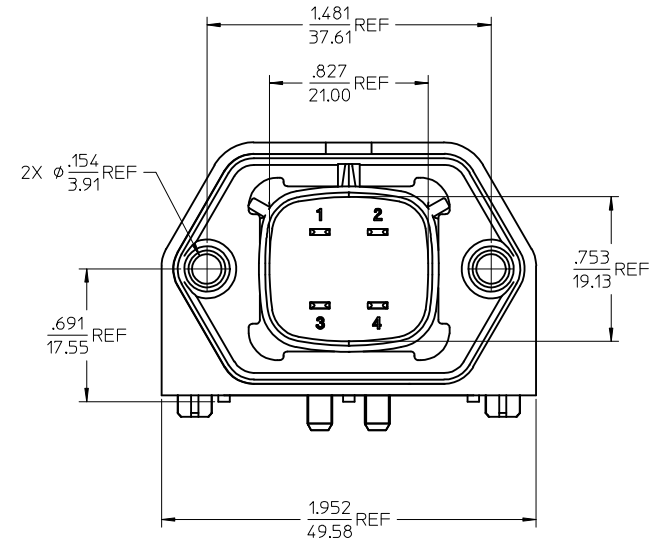
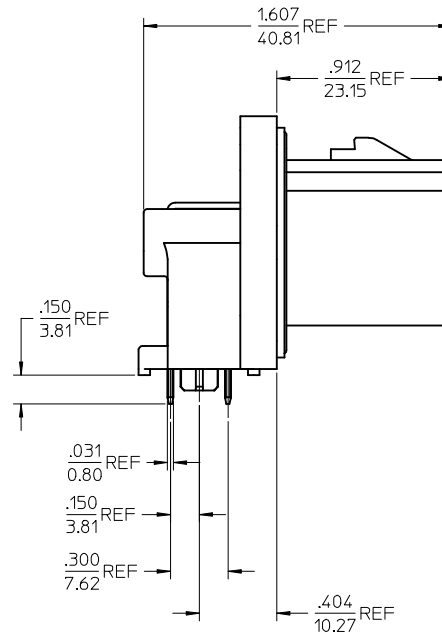
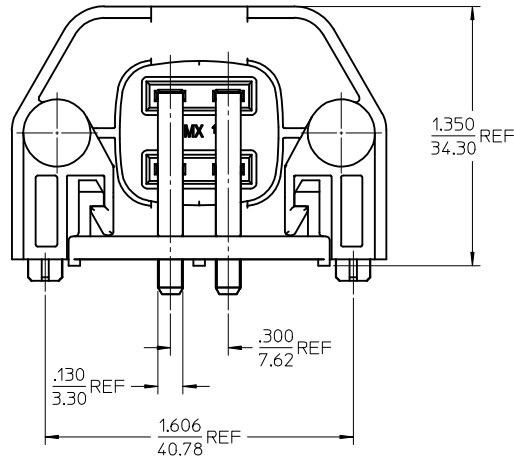

NOTES:

- MATERIALS:
HOUSING: POLYESTER (PBT), GLASS FILLED, UL94 V-0, COLOR: AS NOTED
TERMINALS: COPPER ALLOY
- TERMINAL FINISH: 100HM TIN OVER 504N NICKEL
- PRODUCT SPECIFICATION: PS-19432-001
- PACKAGING SPECIFICATION: PK-19437-001
- MATES WITH: 19432 SERIES RECEPTACLE ASSEMBLIES.
- RECOMMENDED MOUNTING HARDWARE: (2)#10 X .62/15.7 LONG PLASTIC THREAD CUTTING SCREWS. RECOMMENDED TORQUE 15-17 IN-LBS.
SUGGESTED SOURCE: ITW SHAKEPROOF INDUSTRIAL BOSSCREW OR EQUIVALENT.
- ALL MATERIALS ARE ROHS COMPLIANT.

REV	DESCRIPTION
A	ADD CHART EC NO: IPG2017-0429 DRAWN: RUPERT CHKD: APPR: JF MURPHY
	2016/11/07 2016/11/21

QUALITY SYMBOLS
▽=0
▽=0

GENERAL TOLERANCES (UNLESS SPECIFIED)	
mm	INCH
4 PLACES ± .010	± .0004
3 PLACES ± .010	± .0004
2 PLACES ± 0.26	± .010
1 PLACE ± 0.5	± .020
ANGULAR ± 3 °	

DIMENSION STYLE	
IN/MM	
DRAWN BY	DATE
CHECKED BY	DATE
DTITUS	2009/10/16
APPROVED BY	DATE
DTITUS	2009/10/27

SCALE	DESIGN UNITS	THIRD ANGLE PROJECTION
1:1	INCH	THIRD ANGLE PROJECTION
MX150L RA HDR ASSY 4 WAY, 12-10-8AWG WITH PANEL GASKET		
MOLEX INCORPORATED		
MATERIAL NO.	DOCUMENT NO.	SHEET NO.
SEE CHART	SD-19437-020	1 OF 1
THIS DRAWING CONTAINS INFORMATION THAT IS PROPRIETARY TO MOLEX INCORPORATED AND SHOULD NOT BE USED WITHOUT WRITTEN PERMISSION		