

PREFERRED MOUNTING SITUATION FOR CABLE TIE  
 Bevorzugte Montagestellung fuer Kabelbinder

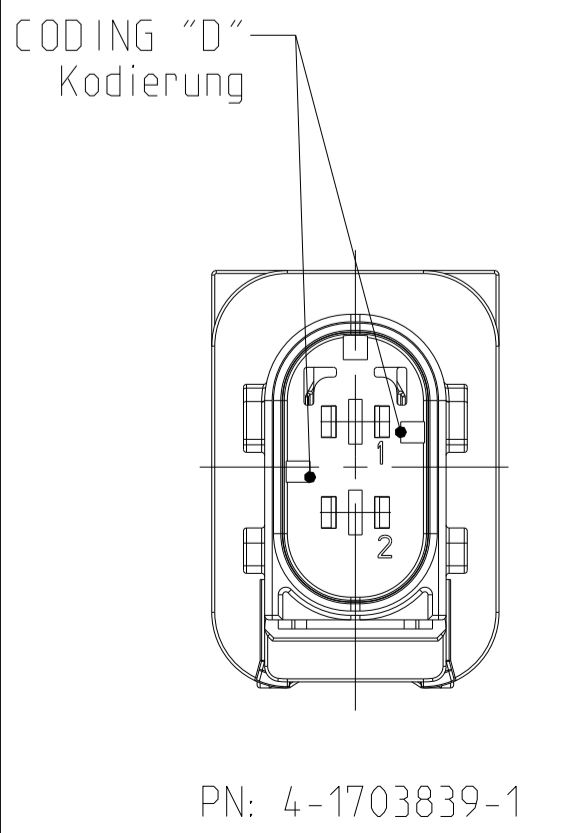

SECTION K-K  
Schnitt

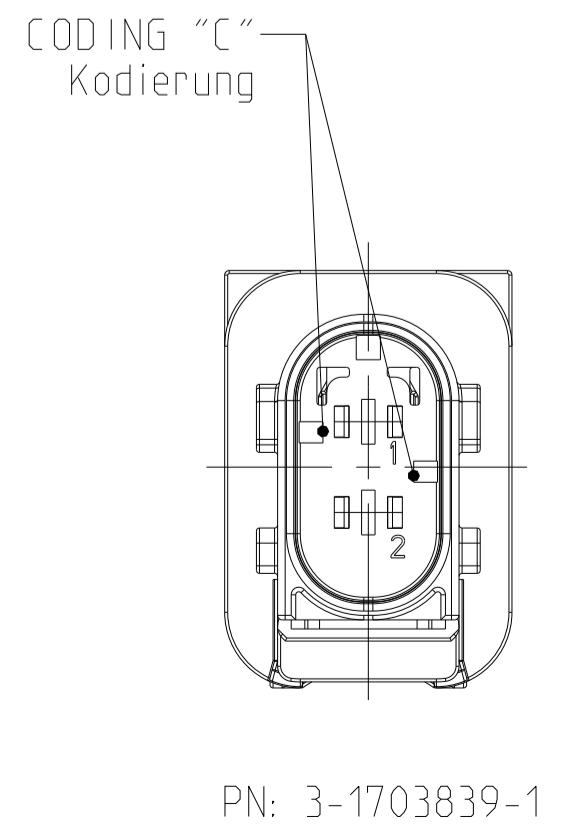
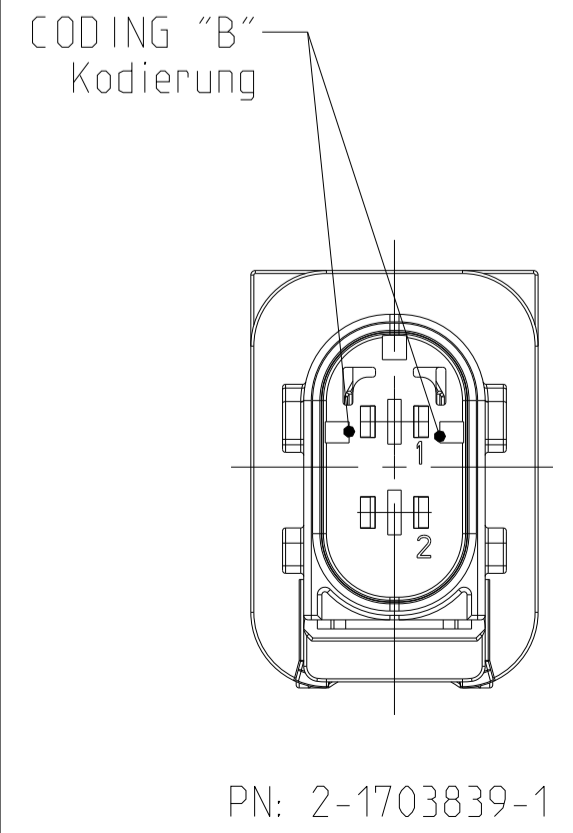
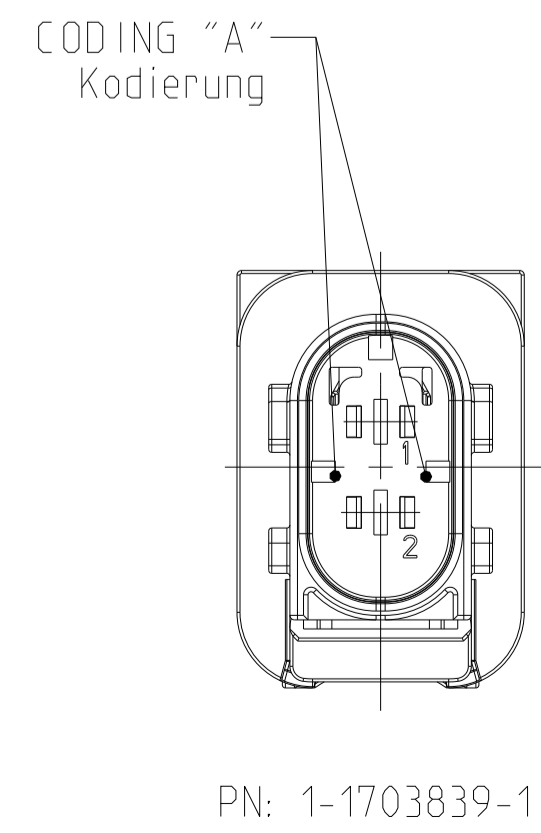
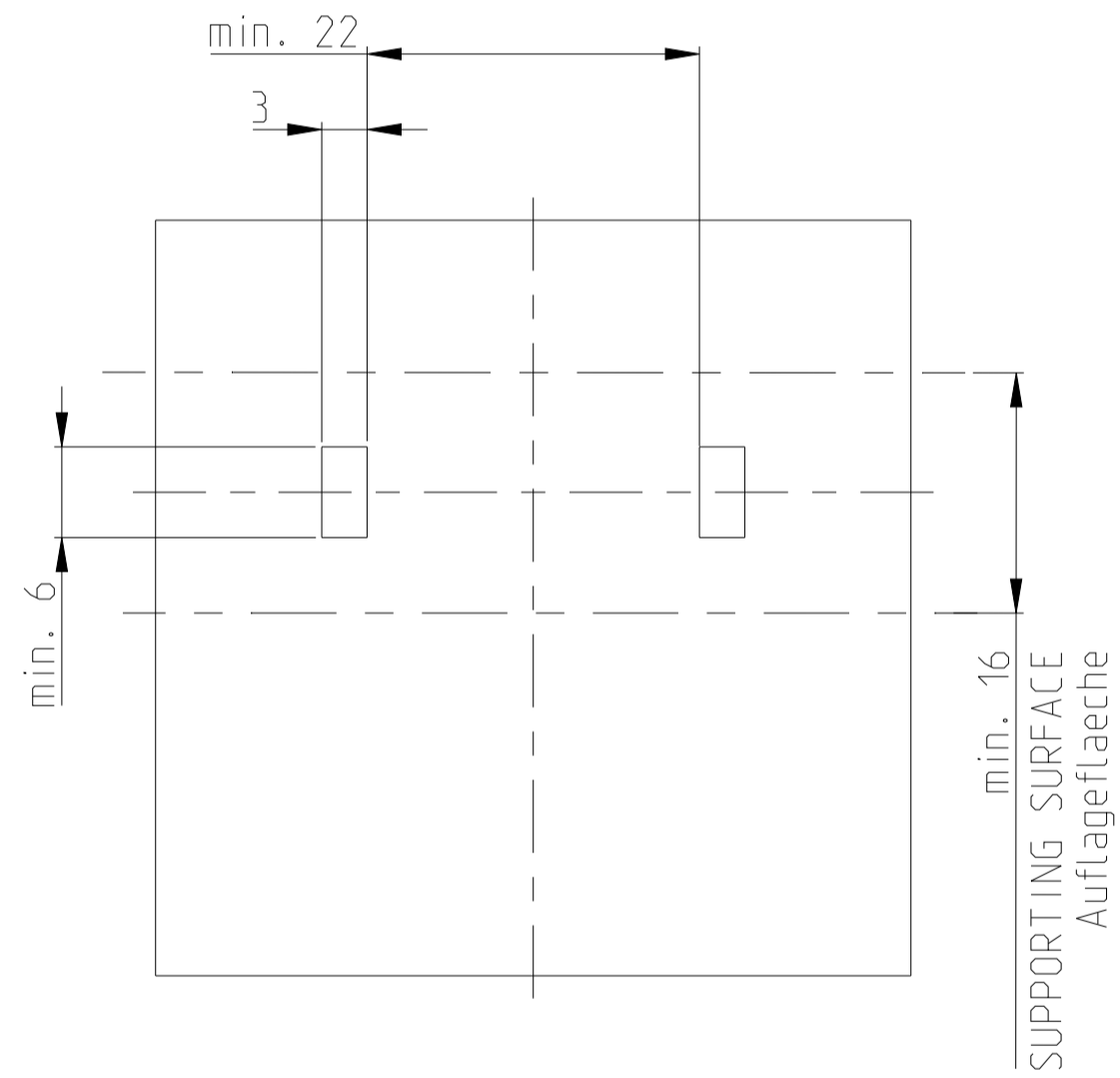
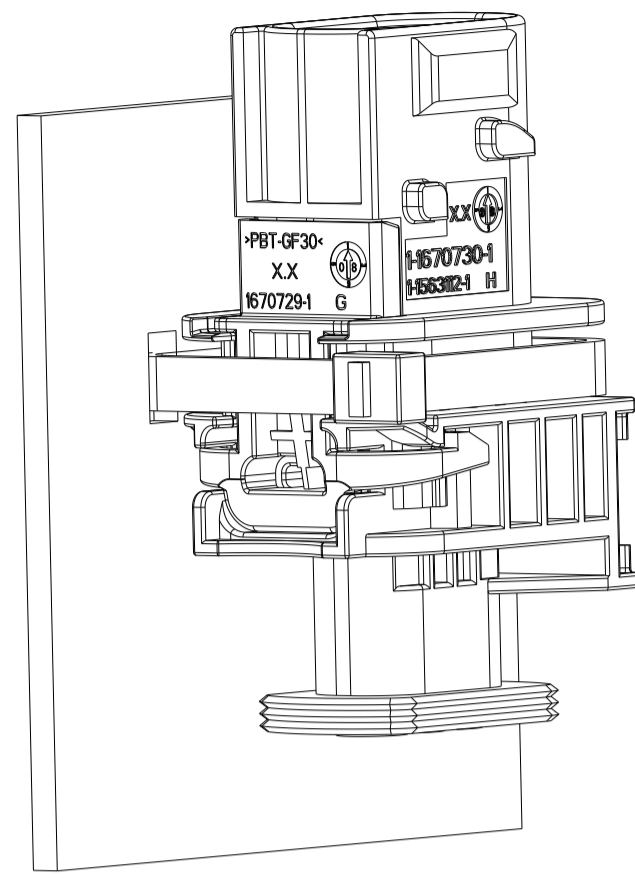
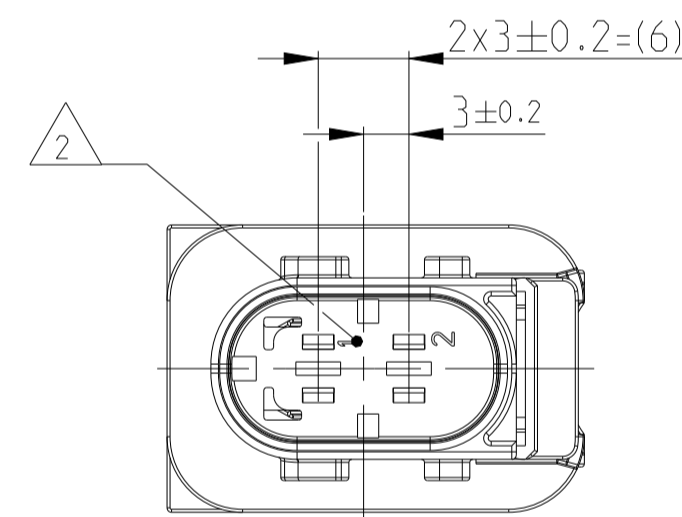
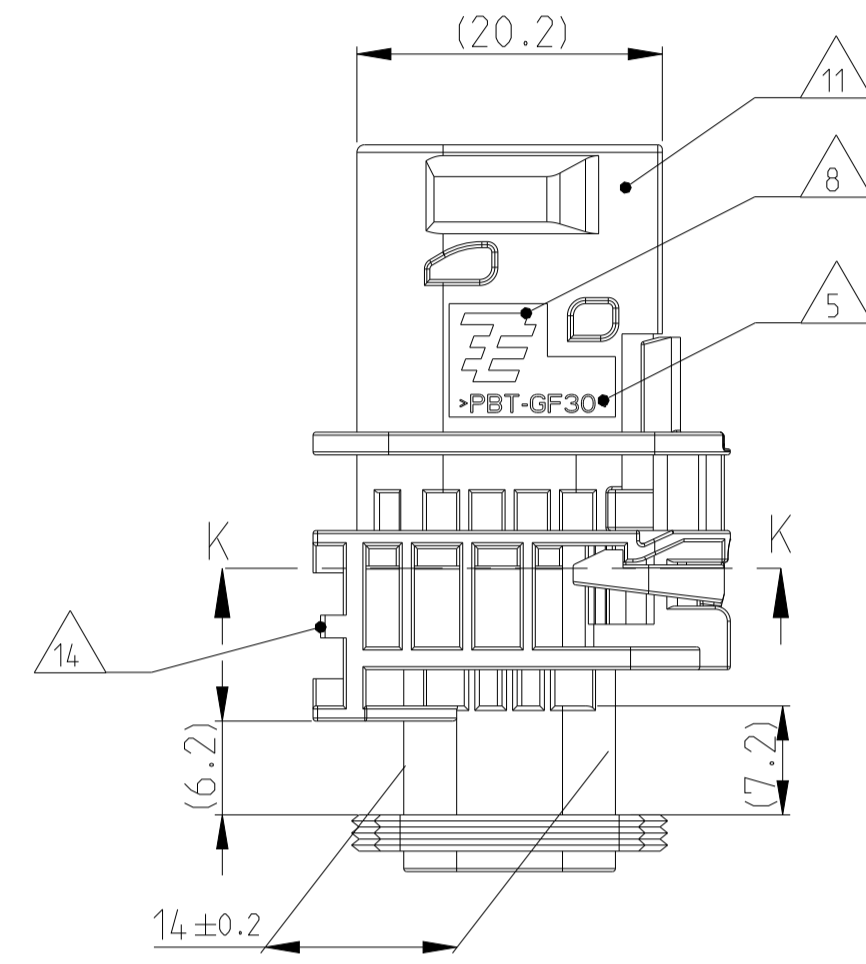
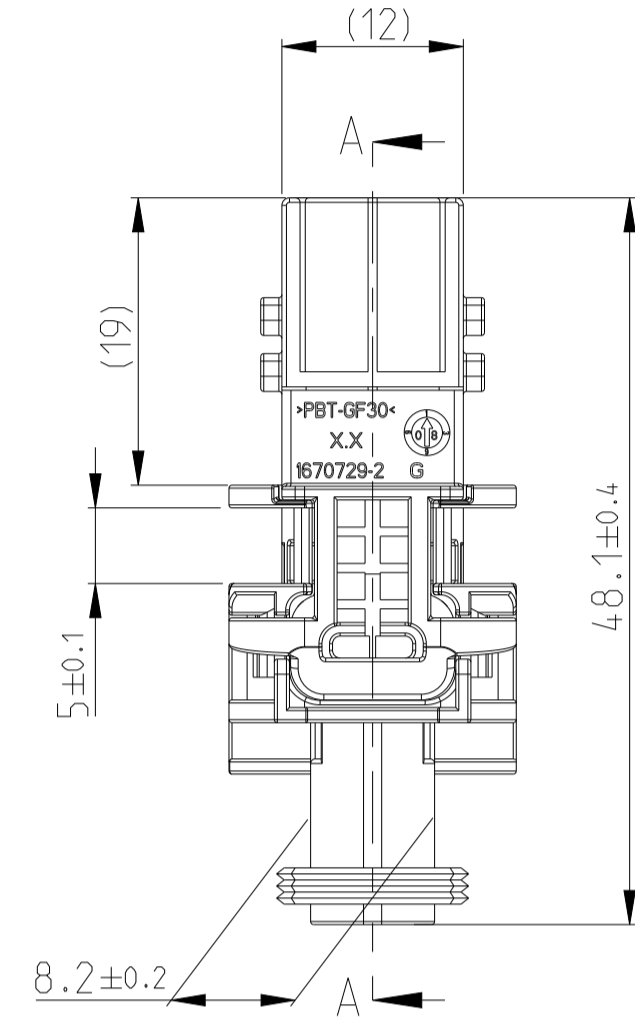
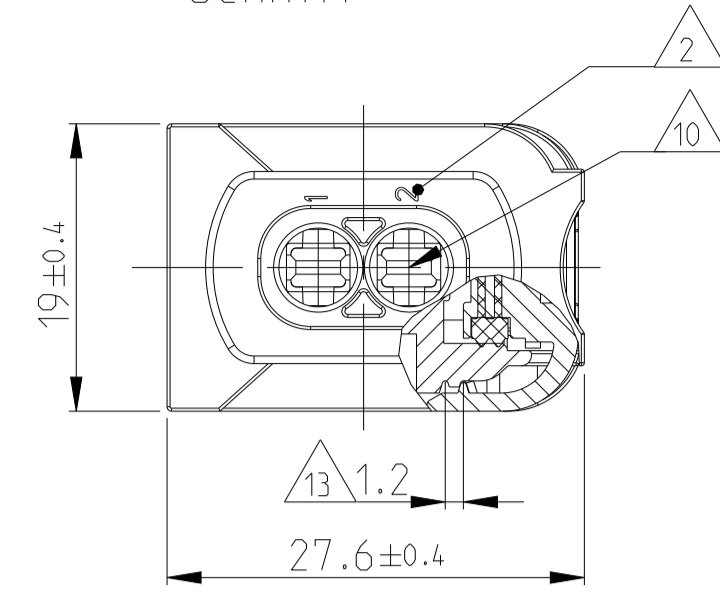

1-1703839-1 AS SHOWN  
 1-1703839-1 wie gezeigt

DELIVERY CONDITION:  
 SECONDARY LOCKING DEVICE  
 IN PRE-LOCKED POSITION  
 Lieferzustand:  
 2. Kontaktsicherung in Vorraststellung

SECTION A-A  
Schnitt

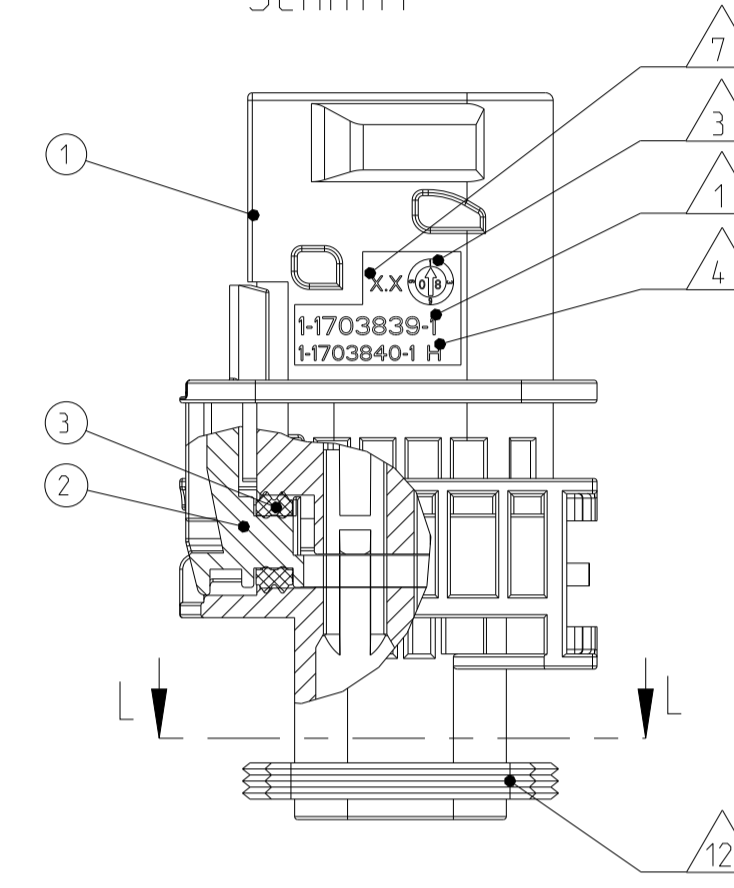

SECTION L-L  
Schnitt

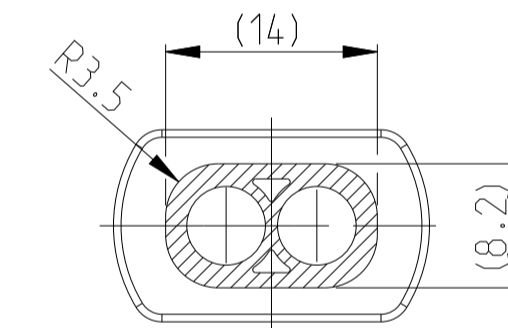

LOC	DIST	REVISIONS			
AI	-	REV.	DESCRIPTION	DATE	BY
EGATN08277		G1	DETAILS SEE PCN E-10-003144	31MAR2011	SJ
		H	DETAILS SEE PCN E-11-002703	31MAR2011	DB
		H1	DETAILS SEE PCN E-11-008836	25MAY2011	CG
		H2	PCN-22-132727	15MAR2022	NS

NOTES  
 Bemerkungen

- TE ORDER-NO.  
TE Bestell-Nr.
- CAVITY NUMBERING  
Kammerbezeichnung
- PRODUCTION DATE  
Produktionsdatum
- LETTER-INSERT FOR THE REVISION STATUS OF THE MOULD  
Schriftsatz fuer Aenderungszustand des Werkzeuges
- MATERIAL MARKING ACCORDING TO VDA 260  
Werkstoffkennzeichnung nach VDA 260
- BULK PACKAGING IN CORRUGATED BOX  
Schuetttgut im Versandkarton
- MOULD CAVITY MARKING  
Nestmarkierung
- TE LOGO  
TE Logo
- SUITABLE COUNTERPART SEE DRAWING: 1418483  
passendes Gegenstueck siehe Zeichnung: 1418483
- CAVITIES MATED WITH TAB 2.8 x 0.8 MM (SW)  
SEE PRODUCT GROUP DRAWING  
TE NO.: 1355052  
MAX. WIRE SIZE: 2.5mm<sup>2</sup> FLR (AWG 12 TXL)  
Kontaktkammer passend fuer Flachstecker 2.8 x 0.8 mm (EDS)  
siehe Produktgruppenzeichnung  
TE Nr.: 1355052  
max. Drahtgroessenbereich: 2.5mm<sup>2</sup> FLR (AWG 12 TXL)
- INTERFACE ACC. DRAWING: 114-18743-1  
Kragenanschluss nach Zeichnung: 114-18743-1
- MATED WITH COVER SEE DRAWING: 1670150,1670365  
Passend zu Kappe siehe Zeichnung: 1670150, 1670365
- SLIDING DISTANCE OF SECONDARY LOCKING  
Verschiebeweg der zweiten Kontaktsicherung
- INTERFACE FOR FIXING PART  
RAYMOND ORDER-NO.: 017530, 018162  
Schnittstelle fuer Befestigungsteil  
Raymond Bestell-Nr.: 017530, 018162
- MAFUNCTION CAUSED BY LAQUER IS NOT COVERED BY TE WARRANTY  
Funktionsbeeintraechtigung durch Lackieren, liegt nicht im Einfluss und Gewaehrleistungsumfang von TE

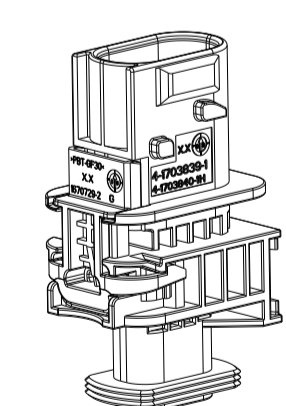
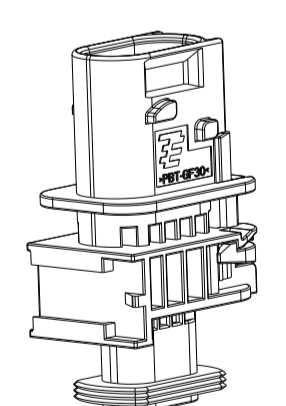

ITEM NO.	DESCRIPTION	COLOUR	MATERIAL
1	2POS. TAB HOUSING, CODE "A" 2pos. Flachsteckergehäuse, Kod. "A"	BLACK schwarz	PBT-GF30 / V-0
1	2POS. TAB HOUSING, CODE "B" 2pos. Flachsteckergehäuse, Kod. "B"	GREY grau	PBT-GF30 / V-0
1	2POS. TAB HOUSING, CODE "C" 2pos. Flachsteckergehäuse, Kod. "C"	GREEN grün	PBT-GF30 / V-0
1	2POS. TAB HOUSING, CODE "D" 2pos. Flachsteckergehäuse, Kod. "D"	YELLOW gelb	PBT-GF30 / V-0
2	SECONDARY LOCKING DEVICE zweite Kontaktsicherung	WHITE weiß	MVO
3	SEAL FOR SECONDARY LOCKING Dichtung fuer 2te Kontaktsicherung	WHITE weiß	MVO

TE ORDER-NO. TE Bestell-Nr.	REV.	NO. OF POS. Polzahl	CODE Kodierung	COLOUR OF HOUSING Farbe des Gehäuses	QUANTITY Stueck	ITEM NO ASSY
4-1703839-1	H	2	D	BLUE blau	1	4
3-1703839-1	H	2	C	GREEN grün	1	3
2-1703839-1	H	2	B	GREY grau	1	2
1-1703839-1	H	2	A	BLACK schwarz	1	1

THIS DRAWING IS A CONTROLLED DOCUMENT.  
 DIESER ZEICHNUNGSDRUCK IST EIN DURCH TE KONTROLLIERTES DOKUMENT.  
 ANFORDERUNG: DIESE ZEICHNUNG NUR FÜR DEN BESTIMMTEN ZWECK UND VORBESTIMMTE PERSONEN ZU VERWENDEN.  
 THE ORIGINAL IS THE ONLY VALID COPY. ANY REVISIONS MUST BE APPROVED BY THE ORIGINAL AUTHOR.

OWNER: S. Jaeger 120K12009  
 CHK: J. Grandzow 130K12009  
 APVD: E. Eberwein 140K12009

PRODUCT SPEC: 108-94.020  
 APPLICATION SPEC: 114-18756

WEIGHT: 10.9g  
 CUSTOMER DRAWING: /KUNDENZEICHNUNG

SCALE: 2:1  
 SHEET: 1 OF 1  
 REV: H2

TE Connectivity

NAME: 2POS. TAB 2.8x0.8 TAB HSG. ASSY  
 HEAVY DUTY SEALED CONNECTOR SERIES - GROUP A

SIZE: A1  
 CAGE CODE: 00779  
 DRAWING NO.: 1703839