

Copying of this document and giving it to others and the use or communication of the contents thereof, are forbidden without express authority. Offenders are liable to the payment of damages. All rights are reserved in the event of the grant of a patent or the registration of the utility model or design.

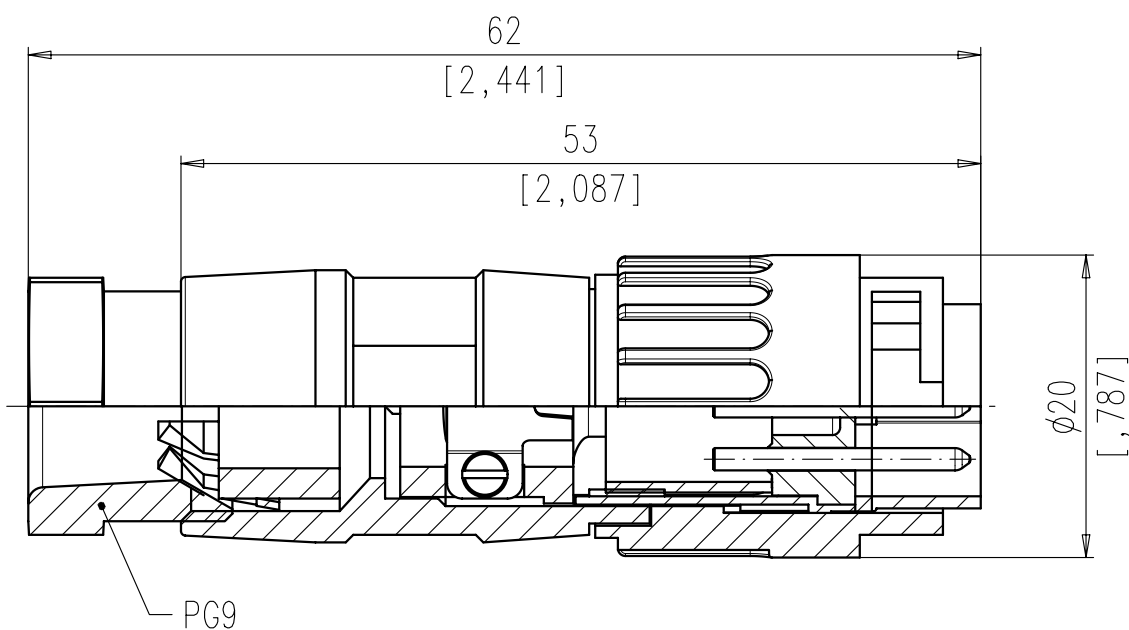

| | | | | | | | | | | | | | |
|---|-------------------------------|---|------------|------------|---------------|---------------|------------|---------------|---------------|---------------------------------|-----|--|--|
| Polzahl number of contacts | Norm standard | 3 | 4 | 5 | 5 | 6 | 7 | 7 | 8 | 12 | 14 | | |
| Kontaktanordnung nach DIN contact arrangement acc. to DIN | | 41524 60130-9 | - 60130-9 | - | 41524 60130-9 | 45322 60130-9 | - | 45329 60130-9 | 45326 60130-9 | - | - | | |
| Kontaktanordnung nach IEC contact arrangement acc. to IEC | | | | | | | | | | | | | |
| Bemessungsspannung rated voltage | IEC 60664-1 | 300V = | | 100V = | 300V = | | 100V = | | 150V = | | | | |
| Bemessungsspannung rated voltage | UL 1977 | 250V | | | | | | | | | 60V | | |
| Bemessungs-Stoßspannung rated impulse withstand voltage | IEC 60664-1 | 1500V | | 1200V | 1500V | | 1200V | | | | | | |
| Verschmutzungsgrad pollution degree | IEC 60664-1 | 1 | | | | | | | | | | | |
| Überspannungskategorie installation category | IEC 60664-1 | I | | | | | | | | | | | |
| Isolierstoffgruppe insulation group | IEC 60664-1 | II, 400 ≤ CTI < 600 | | | | | | | | | | | |
| Strombelastbarkeit current rating | IEC 60512-5-2 Test 5b UL 1977 | 5A / +40°C / +104°F | | | | | | | | 3A / +40°C / +104°F | | | |
| Isolationswiderstand insulation resistance | IEC 60512-3-1 Test 3a | >10 ¹⁰ Ω | | | | | | | | | | | |
| Durchgangswiderstand contact resistance | IEC 60512-2-1 Test 2a | < 5m Ω | | | | | | | | | | | |
| Prüfklasse climatic category | IEC 60068-1 | 40 / 100 / 56 | | | | | | | | | | | |
| Temperaturbereich temperatur range | IEC 60068-1 | -40°C ... +100°C -40°F ... +212°F | | | | | | | | | | | |
| IP-Schutzart IP-degree | IEC 60529 | IP 40 | | | | | | | | | | | |
| Steck- und Ziehkraft Insertion and withdrawal forces | IEC 60512-13-2 Test 13b | 25N 90.oz | 30N 110.oz | 35N 125.oz | 50N 180.oz | 55N 200.oz | 60N 220.oz | 50N 180.oz | | | | | |
| Mechanische Lebensdauer mechanical operation | IEC 60512-9-1 Test 9a | gold/gold ≥ 1000 Steckzyklen/mating cycles | | | | | | | | | | | |
| Werkstoff Gehäuse housing material | | Überwurfmutter Messing, Zugentlastung Zink-Druckguß, Oberfläche vernickelt coupling ring brass, strain relief, die cast, nickel plated | | | | | | | | | | | |
| Werkstoff Kontaktträger dielectric material | | Thermoplast thermoplastic | | | | | | | | | | | |
| Kontaktoberfläche contact plating | | vergoldet * gold plated | | | | | | | | | | | |
| Anschlusstechnik termination technique | | löten solder | | | | | | | | löten solder | | | |
| Anschlussquerschnitt wire gauge | | löten/solder ≤ 0,5 mm ² / 20AWG | | | | | | | | ≤ 0,25 mm ² / 24 AWG | | | |
| Brennbarkeit flammability | | UL 94 V0 | | | | | | | | | | | |
| Verriegelung locking system | | Bojonett bayonet | | | | | | | | | | | |

| | | |
|---------------|----------------------------|------------------------------|
| | 14 | T 3649 528 |
| | 12 | T 3629 528 |
| | 8 IEC | T 3529 528 |
| | 7 IEC | T 3449 528 |
| | 7 | T 3439 528 |
| | 6 | T 3429 528 |
| | 5 | T 3379 528 |
| | 5 IEC | T 3399 528 |
| | 4 | T 3329 528 |
| | 3 | T 3279 528 |
| SYMBOL symbol | POLZAHL number of contacts | TYP-NUMMER-AU type-number-AU |

Diese Steckverbinder dürfen betriebsmäßig nicht unter Spannung betätigt werden. Metallene Gehäuseteile sind sicher mit dem Schutzleitersystem zu verbinden.
 Do not connect or disconnect under load. Metal housing parts shall be securely incorporated to protected ground.
 * Hinweis für vergoldete Anschlüsse:
 Zur Vermeidung von spröden intermetallischen Verbindungen müssen vergoldete Anschlüsse vor dem eigentlichen Lötvorgang verzinnt werden.

Remark for gold plated contacts:
 In order to avoid brittle inter-metallic connections, gold-plated terminals have to be tin-plated in the solder area.

| | | | | | | | |
|-------------------------------|----------------------|-----------------------|------------|--|----------------------------------|----|--|
| Gewicht (errechnet)/ Calc WT: | 9 | Zul. Abw./Tolerances: | | Maßstab/Scale | 2:1 | A3 | |
| Prüfmaß/Test dimension | | | | CUSTOMER DRAWING | | | |
| Teileindex Part index number | | | | Kabelstecker gerade Male cable connector | | | |
| | | 08 | Datum/Date | Name | Amphenol-Tuchel Electronics GmbH | | |
| | | Gez. 08.07. | | Cionvica | HB T 3XX9 528 | | |
| | | Drawn | | | M | | |
| | | Gep. ? | | | 1 | | |
| | | Checked | | | 1 Bl. | | |
| 01 | 200700144 | 08.07.08 | CI | Ers. f./Similar to: | | | |
| Index | Änderung/Description | Datum/Date | Name | | | | |