

FSR UX™

Force Sensing Resistors®



Global human machine interface (HMI) leader, Interlink Electronics—the originator of the Force Sensing Resistor* (FSR)—expands its signature line of sensors with the FSR UX.

The improved design of the FSR UX offers a greatly expanded dynamic sensing range that extends from 0.5N to 150N, providing enhanced precision and broadening the scope of the FSR UX's potential applications.

The FSR UX 400 series comprises a full range of models in various sizes, shapes, and configurations, all of which can be utilized for custom sensing solutions.

FEATURES

- Improved sensing range extends from 0.5N to 150N
- Ultrathin form factor
- Able to withstand extreme temperatures and conditions
- Tested to 10 million actuations
- Simple and easy to integrate
- Customizable to a wide range of applications
- Cost effective

APPLICATIONS

- Industrial
- Robotics
- Medical
- Automotive
- Computing
- IoT
- Wearable Technology

*Force Sensing Resistors are robust polymer thick film (PTF) devices that exhibit a decrease in resistance when increased force is applied to the surface of the sensor.



Device Characteristics

Sensor Resistance Output	Analog
Actuation Force	0.5N (min)
Force Sensing Range	0.5N – 150N
Force Repeatability Single Part	+/-2%
Force Repeatability Part to Part	+/-5% (Single Batch)
No-Load Resistance	>10 MΩ
Hysteresis	+5% (RF+ – RF-)/RF+
Long Term Drift @ 5kg, 10 days	< 4% log10(time)
Operating Temperature Performance	
Cold: -25°C after 1 hour	+1% resistance change
Hot: +85°C after 1 hour	+3% resistance change
Storage Temperature Performance	
Cold: -40°C after 120 hours	+1% resistance change
Hot: +85°C after 120 hours	+3% resistance change
Tap Durability	
Tested to 10 Million actuations @1kg, 4Hz	-10% resistance change
Thermal Shock @85°C to -40°C, 20 Cycles	+2% resistance change
Standing Load Durability	
2.5kg for 24 hours	-3% resistance change
UL	All materials UL grade 94 V-1 or better
RoHS	Compliant

Sensor Mechanical Data:

Active Area: Ø14.68mm
 Nominal Thickness: 0.46mm
 Switch Travel: 0.15mm

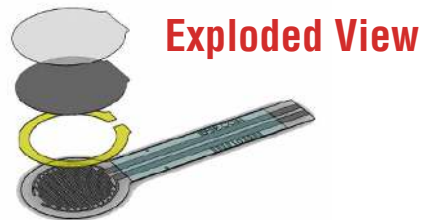
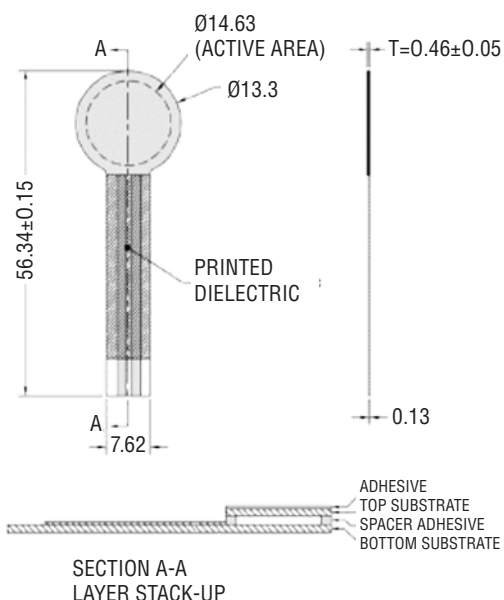

United States Corporate Office

Interlink Electronics, Inc.
 1267 Flynn Road
 Camarillo, CA 93012, USA

Phone: +1.805.484.8855
 Fax: +1.805.484.9457

InterlinkElectronics.com
 Sales & Support: sales@iefsr.com

Interlink Electronics reserves the right to make changes without further notice to any products or specifications herein and does not assume any responsibility or liability arising out of the application or use of any its products or circuits.

NOTES

1. Specifications are derived from average measurements taken at 5,000 grams and are given as (one standard deviation/mean), unless otherwise noted. Measurement is dependent on actuation interface, mechanics, and measurement electronics.
2. The test was performed using FSR UX 402 design.
3. Additional information is available upon request.