

SLIDE SWITCHES (SMD)

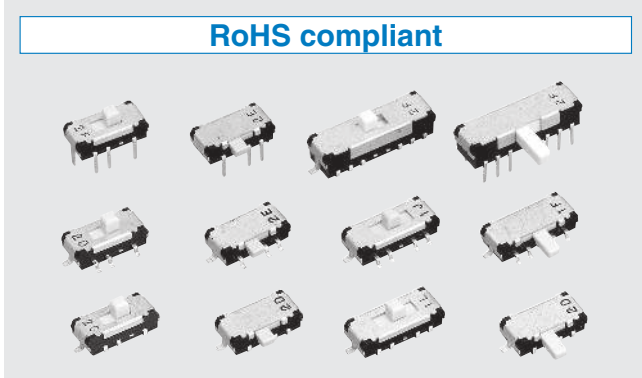

RoHS compliant



FEATURES

- RoHS compliant
- Excellent contact stability by twin Gold-plated contact mechanism
- Load life of 30,000 cycles
- Compatible with automatic mounting
- Withstands high soldering temperature

INTERNAL STRUCTURE

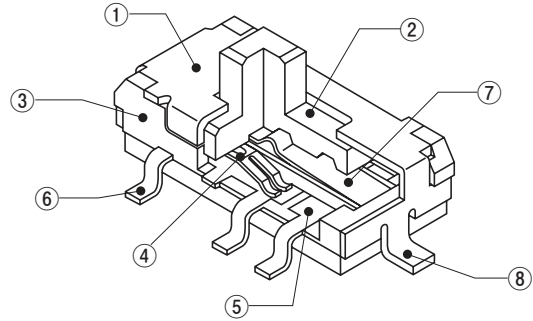

Part name	Material	Flammability
① Cover	Steel (SPCC), Tin-plated	—
② Slider	Polyamide	UL94V-0
③ Housing		
④ Slider contact	Copper alloy, Gold-plated	—
⑤ Fixed contact		
⑥ Terminal pin	Copper alloy	—
⑦ Click spring		
⑧ Ground terminal	Steel (SPCC), Tin-plated	—

PART NUMBER DESIGNATION

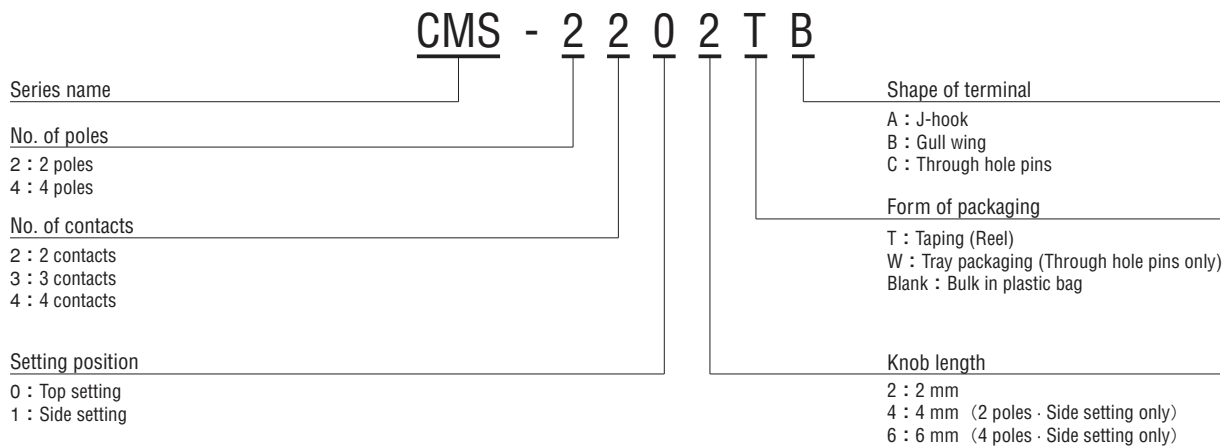

※ Please refer to the LIST OF PART NUMBERS when placing orders.

LIST OF PART NUMBERS

● 2 poles

Setting position	Shape of terminals	Knob length	Form of packaging	No. of contacts			Pieces in package
				2	3	4	
Top setting	A (J-hook)	2 mm	Taping	CMS-2202TA	CMS-2302TA	CMS-2402TA	900 pcs./reel
			Plastic bag	CMS-2202A	CMS-2302A	CMS-2402A	50 pcs./pack
	B (Gull wing)		Taping	CMS-2202TB	CMS-2302TB	CMS-2402TB	900 pcs./reel
			Plastic bag	CMS-2202B	CMS-2302B	CMS-2402B	50 pcs./pack
	C (Through hole pins)		Tray packaging	CMS-2202WC	CMS-2302WC	CMS-2402WC	50 pcs./tray
			Plastic bag	CMS-2202C	CMS-2302C	CMS-2402C	50 pcs./pack
Side setting	A (J-hook)	2 mm	Taping	CMS-2212TA	CMS-2312TA	CMS-2412TA	900 pcs./reel
			Plastic bag	CMS-2212A	CMS-2312A	CMS-2412A	50 pcs./pack
		4 mm	Taping	CMS-2214TA	CMS-2314TA	CMS-2414TA	900 pcs./reel
			Plastic bag	CMS-2214A	CMS-2314A	CMS-2414A	50 pcs./pack
	B (Gull wing)	2 mm	Taping	CMS-2212TB	CMS-2312TB	CMS-2412TB	900 pcs./reel
			Plastic bag	CMS-2212B	CMS-2312B	CMS-2412B	50 pcs./pack
		4 mm	Taping	CMS-2214TB	CMS-2314TB	CMS-2414TB	900 pcs./reel
			Plastic bag	CMS-2214B	CMS-2314B	CMS-2414B	50 pcs./pack
	Through hole pins	2 mm	Tray packaging	CMS-2212WC	CMS-2312WC	CMS-2412WC	50 pcs./tray
			Plastic bag	CMS-2212C	CMS-2312C	CMS-2412C	50 pcs./pack
		4 mm	Tray packaging	CMS-2214WC	CMS-2314WC	CMS-2414WC	50 pcs./tray
			Plastic bag	CMS-2214C	CMS-2314C	CMS-2414C	50 pcs./pack

● 4 poles

Setting position	Shape of terminals	Knob length	Form of packaging	No. of contacts	Pieces in package
				2	
Top setting	A (J-hook)	2 mm	Taping	CMS-4202TA	500 pcs./reel
			Plastic bag	CMS-4202A	25 pcs./pack
	B (Gull wing)		Taping	CMS-4202TB	500 pcs./reel
			Plastic bag	CMS-4202B	25 pcs./pack
	C (Through hole pins)		Tray packaging	CMS-4202WC	50 pcs./tray
			Plastic bag	CMS-4202C	25 pcs./pack
Side setting	A (J-hook)	6 mm	Taping	CMS-4216TA	500 pcs./reel
			Plastic bag	CMS-4216A	25 pcs./pack
	B (Gull wing)		Taping	CMS-4216TB	500 pcs./reel
			Plastic bag	CMS-4216B	25 pcs./pack
	C (Through hole pins)		Tray packaging	CMS-4216WC	50 pcs./tray
			Plastic bag	CMS-4216C	25 pcs./pack

※ Verify the above part numbers when placing orders.
Taping and tray version can be supplied only in reel or tray unit.

STANDARD SPECIFICATIONS

Operating temp. range	- 40 ~ 85 °C	
Storage temp. range		
Sealing	Non- Washable	
Net weight	0.40 g (CMS-2202) 0.45 g (CMS-2302) 0.50 g (CMS-2402) 0.42 g (CMS-2212) 0.48 g (CMS-2312) 0.54 g (CMS-2412)	0.42 g (CMS-2214) 0.48 g (CMS-2314) 0.54 g (CMS-2414) 0.80 g (CMS-4202) 0.84 g (CMS-4216)

ELECTRICAL CHARACTERISTICS

Contact rating Non-switching Switching Minimum	DC50 V 100 mA DC12 V 100 mA DC20 mV 1 μ A
Contact timing	Non-shorting
Contact resistance	70 m Ω maximum
Insulation resistance	100 M Ω minimum (DC500 V)
Dielectric strength	AC500 V, 60 s

MECHANICAL CHARACTERISTICS

No. of positions	2, 3, 4
Stroke	2 mm
Operating force	1.5 ± 1 N {0.15 ± 0.1 kgf}
Stop strength	30N{3.06 kgf} 15 s (Top setting) 10N{1.02 kgf} 15 s (Side setting)
Solderability	245 ± 3 °C 2 ~ 3 s
Soldering heat	Reflow : 255 °C (Peak temperature) (Please refer to the profile below)
	Flow : 260 ± 3 °C、5~ 6 s
	Manual soldering : 350 ± 10 °C, 3 ~ 4 s
Shear (Adhesion)	50 N {5.09 kgf} 10 s
Substrate bending	Width 90 mm, bend 3 mm, 5 s, 1 time
Pull-off strength	50 N {5.09 kgf} 10 s

{ } : Reference only

ENVIRONMENTAL CHARACTERISTICS

Vibration	(Amplitude) 1.5 mmor (Acceleration) 98 m/s ² , 10-500-10 Hz, 3 directions for 10 cycles each
Shock	490 m/s ² , 11 ms, sinusoidal wave half cycle, 6 directions for 3 times each
Load life	Continuous load 30000 cycles, DC12 ± 0.5 V, 100 ± 10 mA
Humidity	40 °C, Relative humidity 90 ~ 95 %, 240 h, No load
High temp. exposure	85 °C, 96 h, No load
Low temp. exposure	- 40 °C, 96 h, No load
Thermal shock	- 40 (0.5 h) ~ 85 °C (0.5 h), 5 cycles

<Reflow profile for soldering heat evaluation>

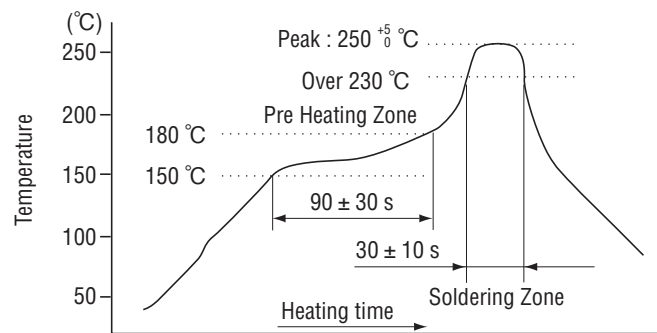

Reflow : two times maximum

OUTLINE DIMENSIONS

Unless otherwise specified, tolerance : ± 0.3 (Unit : mm)

● CMS-2202A

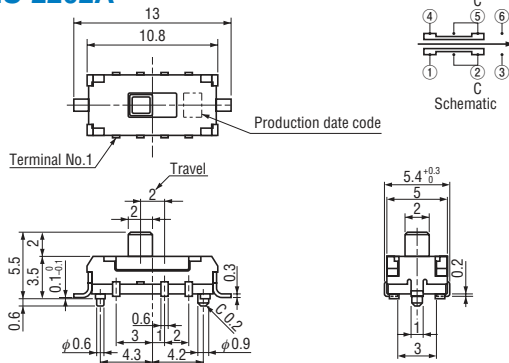

● CMS-2202B

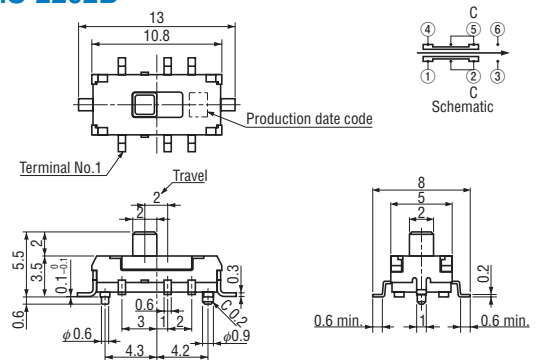

● CMS-2202C

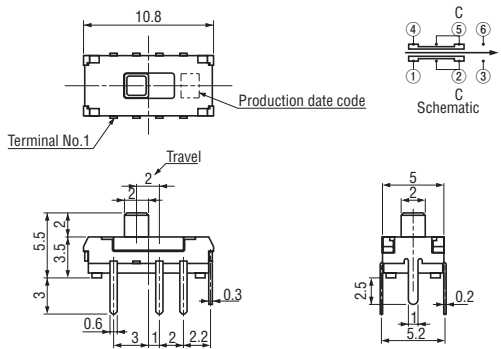

● CMS-2212A

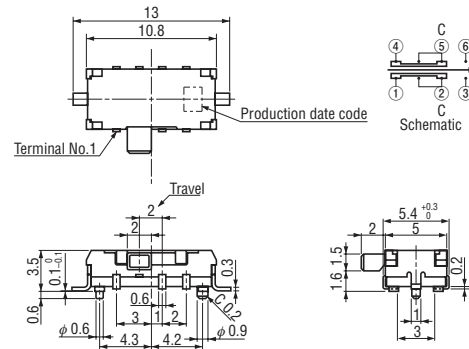

● CMS-2212B

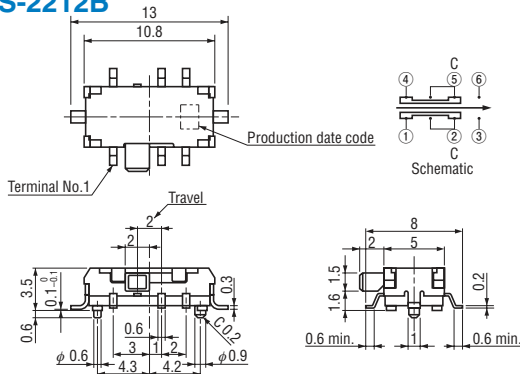

● CMS-2212C

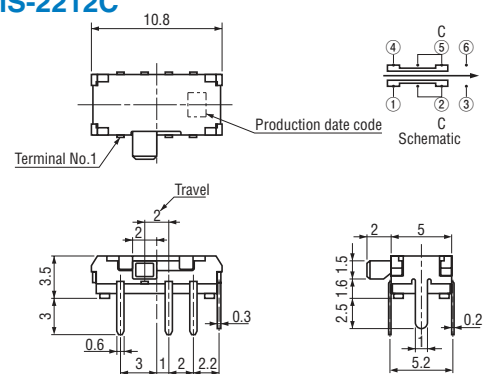

● CMS-2214A

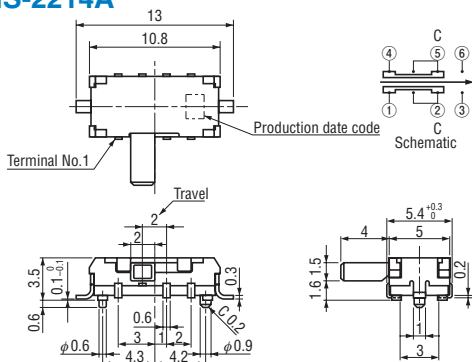

● CMS-2214B

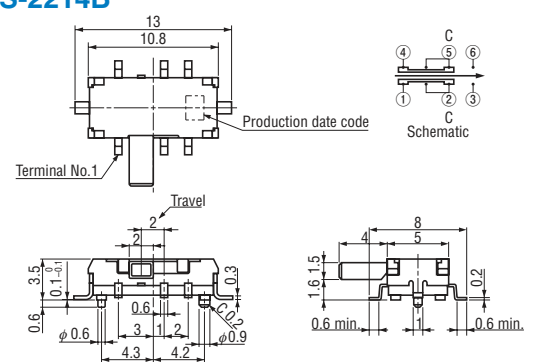

CMS

SLIDE SWITCHES (SMD)

OUTLINE DIMENSIONS

Unless otherwise specified, tolerance : ± 0.3 (Unit : mm)

● CMS-2214C

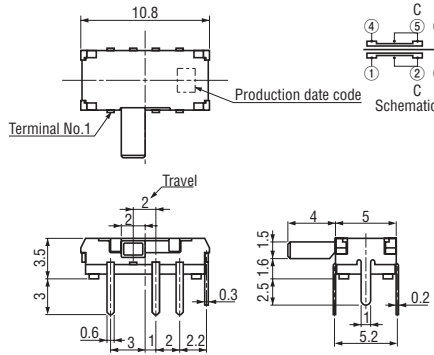

● CMS-2302A

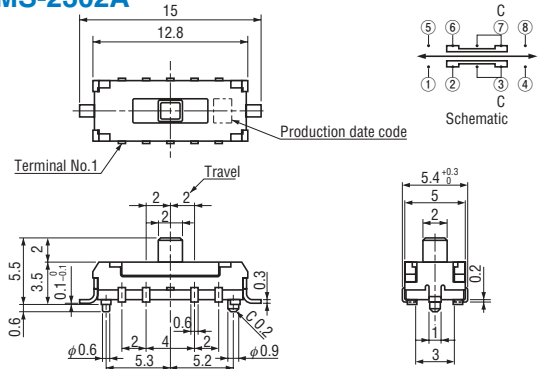

● CMS-2302B

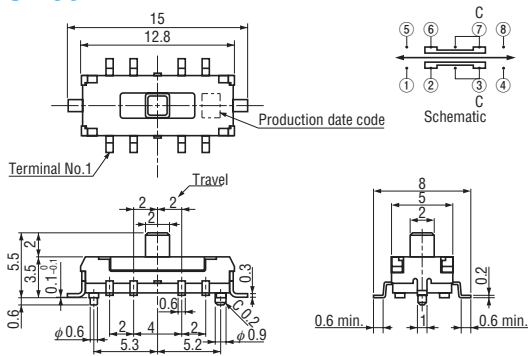

● CMS-2302C

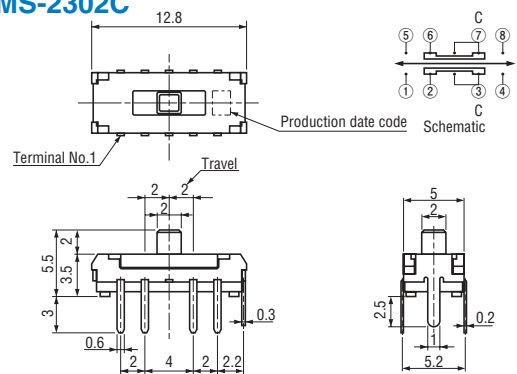

● CMS-2312A

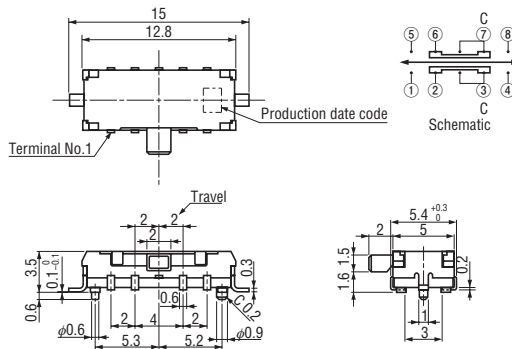

● CMS-2312B

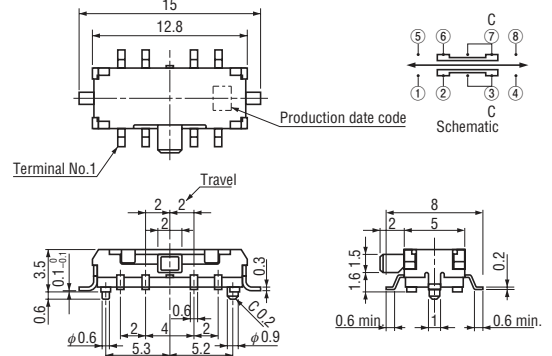

● CMS-2312C

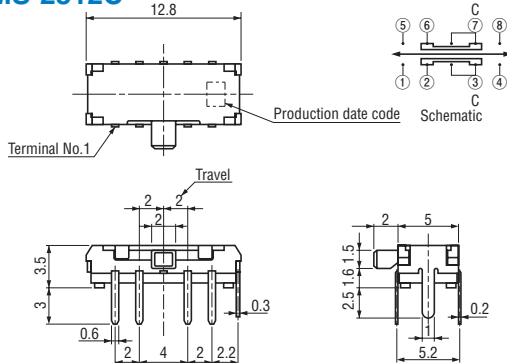

● CMS-2314A

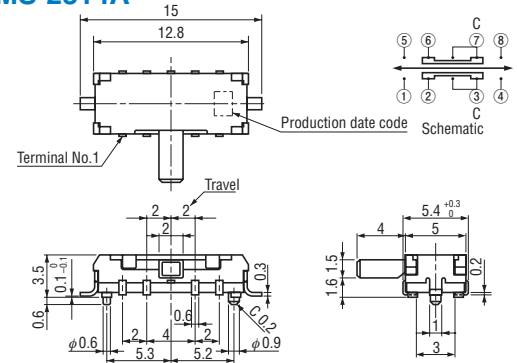

OUTLINE DIMENSIONS

Unless otherwise specified, tolerance : ± 0.3 (Unit : mm)

● CMS-2314B

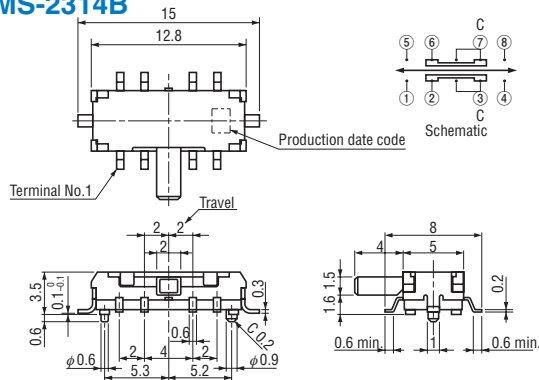

● CMS-2314C

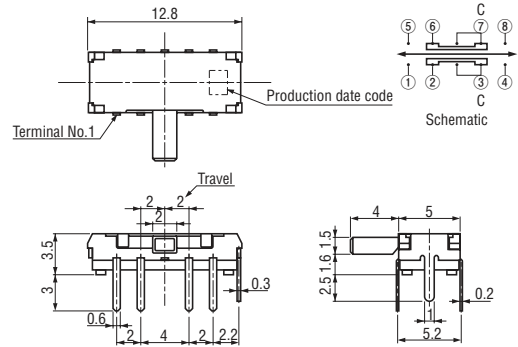

● CMS-2402A

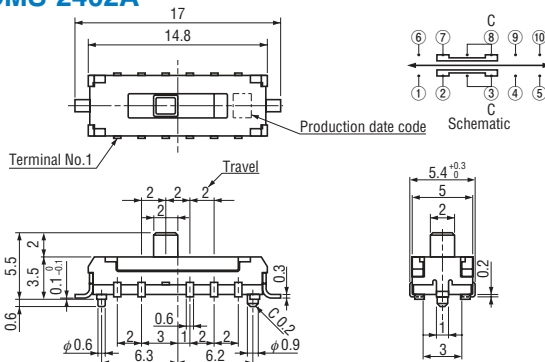

● CMS-2402B

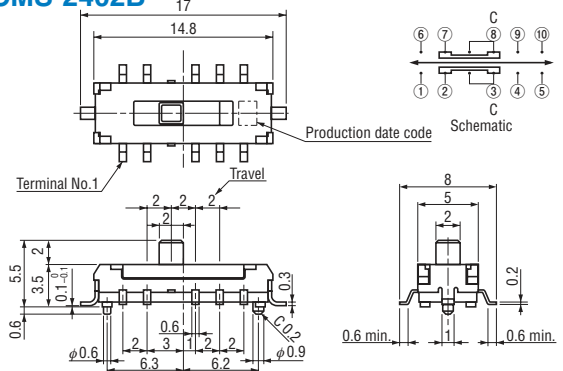

● CMS-2402C

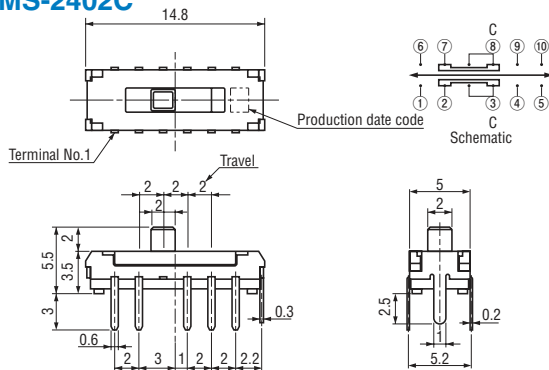

● CMS-2412A

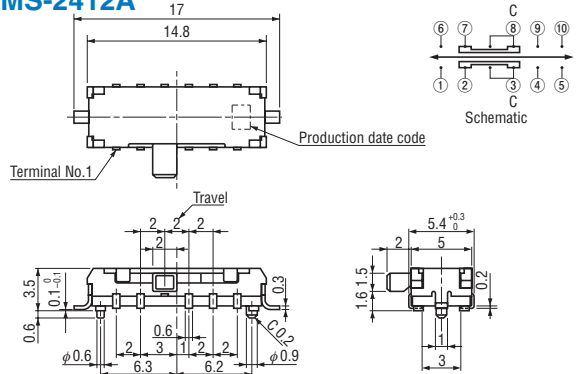

● CMS-2412B

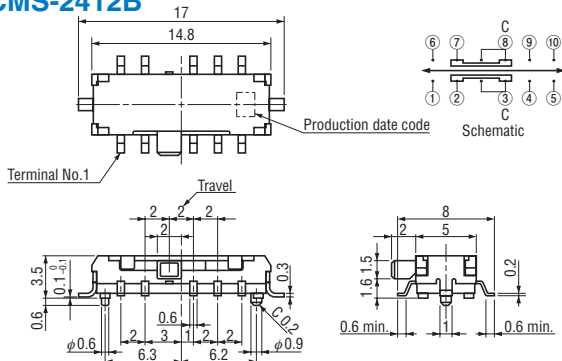

● CMS-2412C

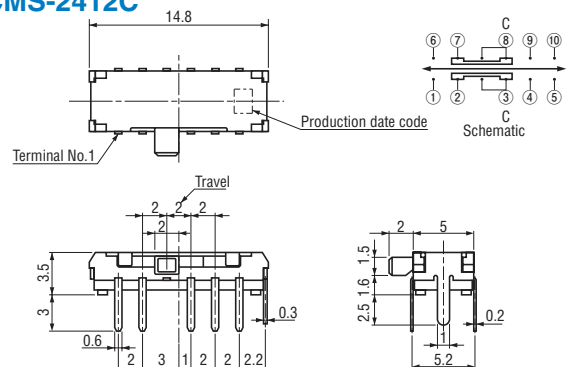

CMS

SLIDE SWITCHES (SMD)

OUTLINE DIMENSIONS

Unless otherwise specified, tolerance : ± 0.3 (Unit : mm)

● CMS-2414A

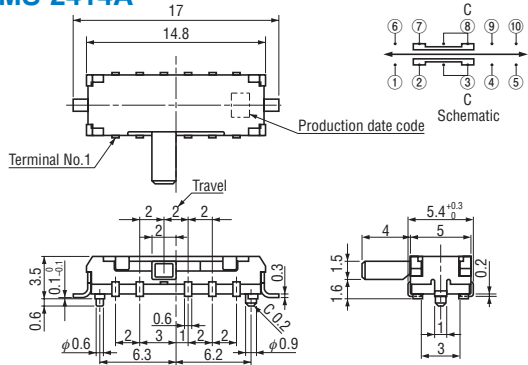

● CMS-2414B

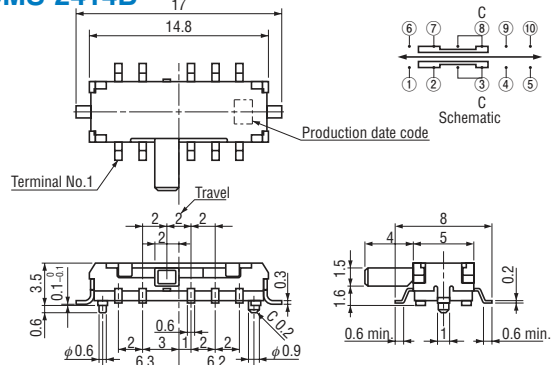

● CMS-2414C

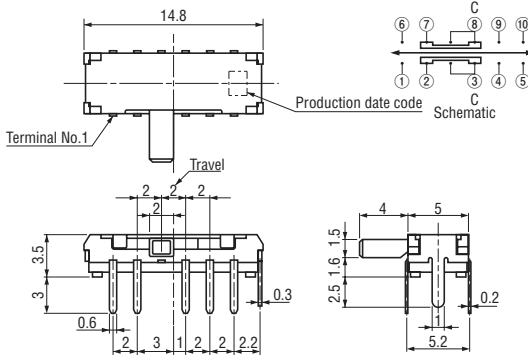

● CMS-4202A

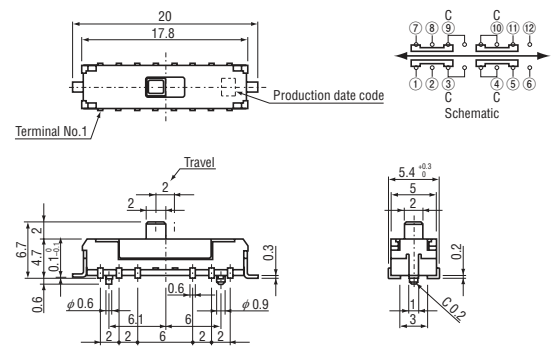

● CMS-4202B

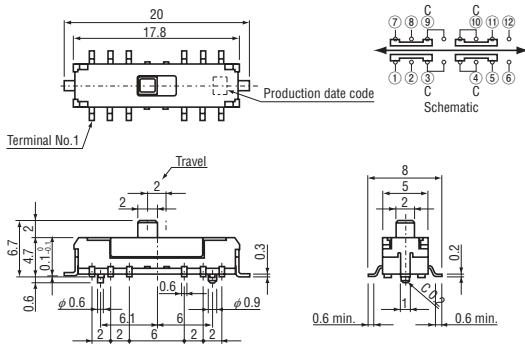

● CMS-4202C

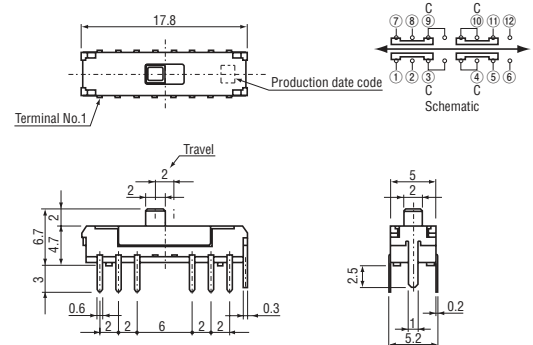

● CMS-4216A

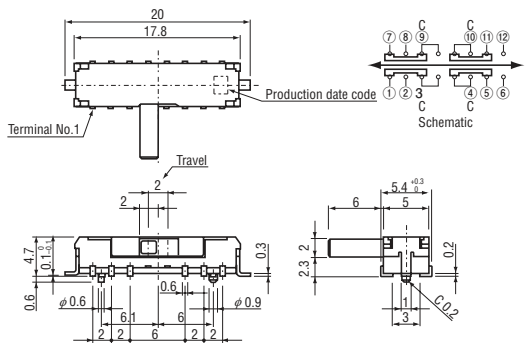

● CMS-4216B

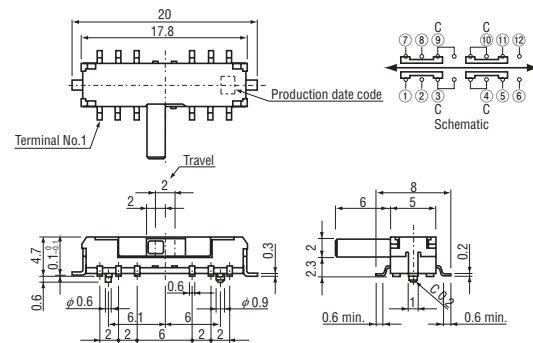

OUTLINE DIMENSIONS

Unless otherwise specified, tolerance : ± 0.3 (Unit : mm)

● CMS-4216C

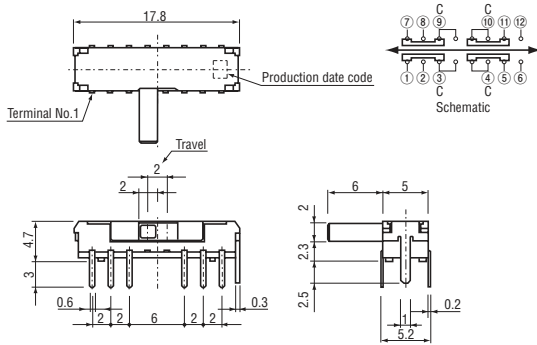

SIZE OF P.C.B. PROCESSING

(Unit : mm)

● CMS-22□□C

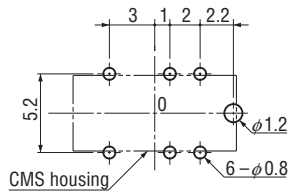

● CMS-23□□C

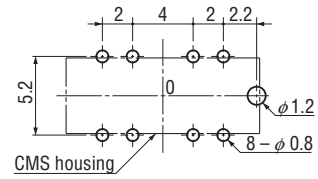

● CMS-24□□C

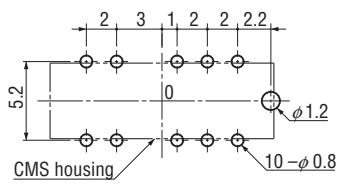

● CMS-42□□C

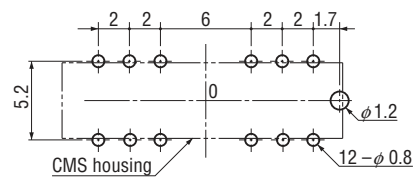

CMS

SLIDE SWITCHES (SMD)

RECOMMENDED P.C.B. PAD OUTLINE DIMENSIONS

● CMS-22□□A

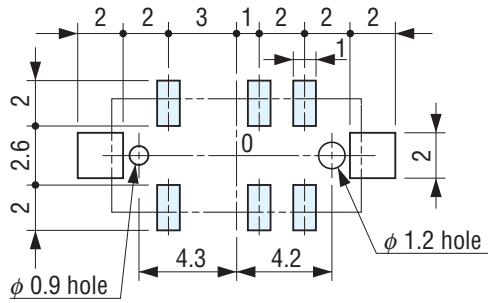

● CMS-22□□B

(Unit : mm)

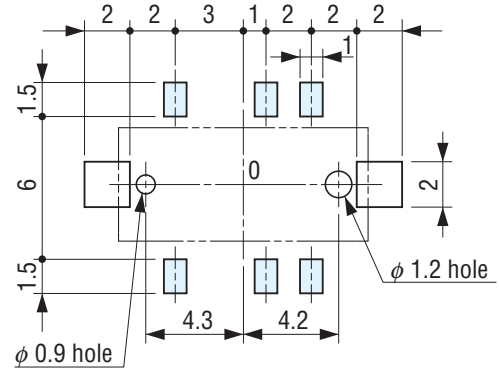

● CMS-23□□A

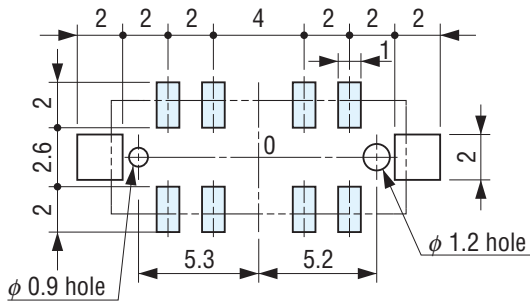

● CMS-23□□B

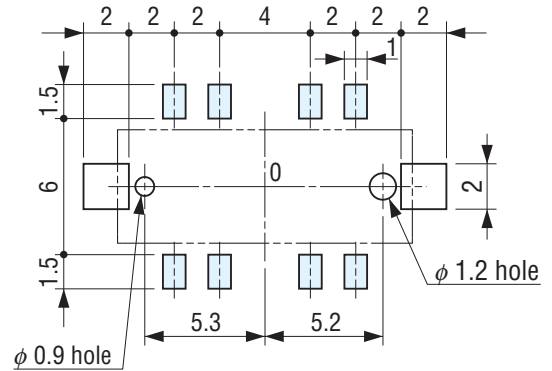

● CMS-24□□A

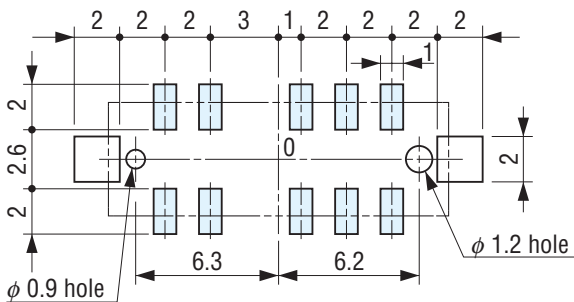

● CMS-24□□B

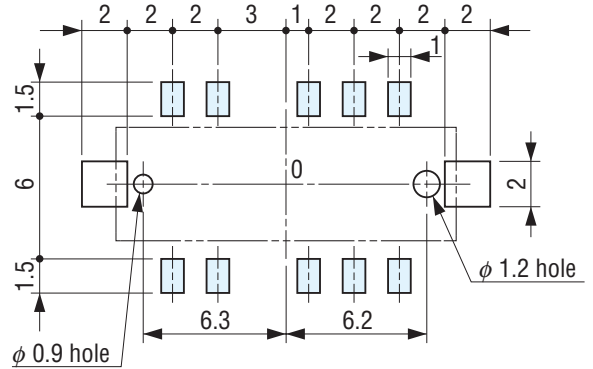

● CMS-42□□A

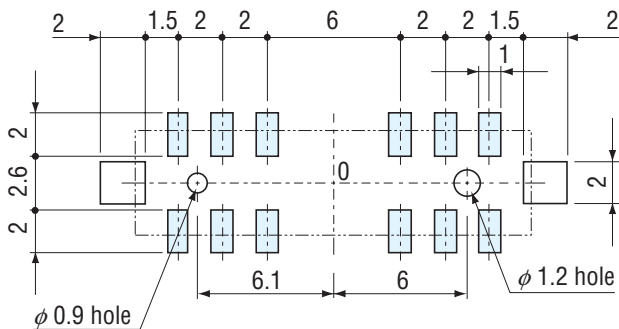

● CMS-42□□B

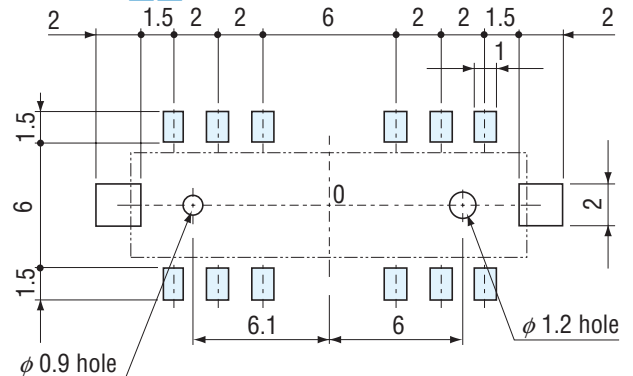

Note) The zero point is the center of mounting.

PACKAGING SPECIFICATIONS

<Taping packaging specifications>

- CMS-2 □□□□ type is packaged in 900 pcs. per reel. Orders will be accepted for units of 900 pcs., i.e., 900, 1800, 2700 pcs., etc. CMS-4 type is packaged in packaged in 500 pcs. per reel. Orders will be accepted for units of 500 pcs.

- Taping version is boxed with one reel.

Maximum number of consecutive missing pieces=2
Leader length and reel dimension are shown in the diagrams below:

● Embossed tape dimensions

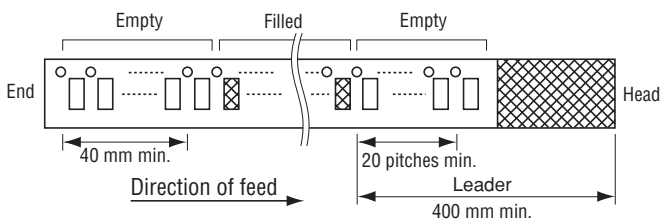

● Reel dimensions

(Unit: mm)
(Conforms to JIS C 0806)
(In accordance with EIAJ ET-7200A)

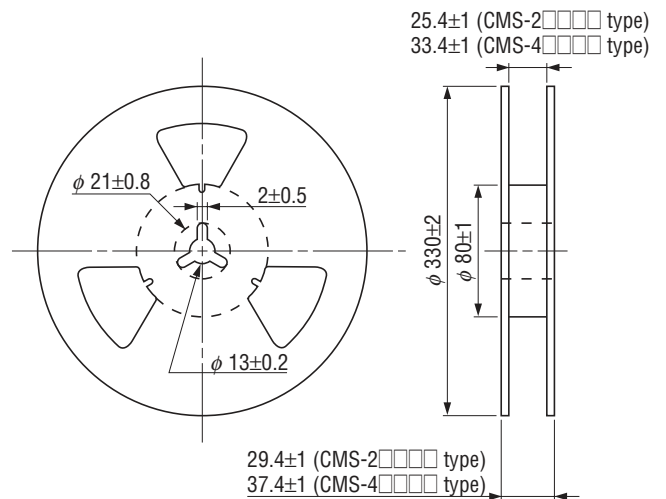

● CMS-2202TA, TB

(Unit : mm)
(Conforms to JIS C 0806)

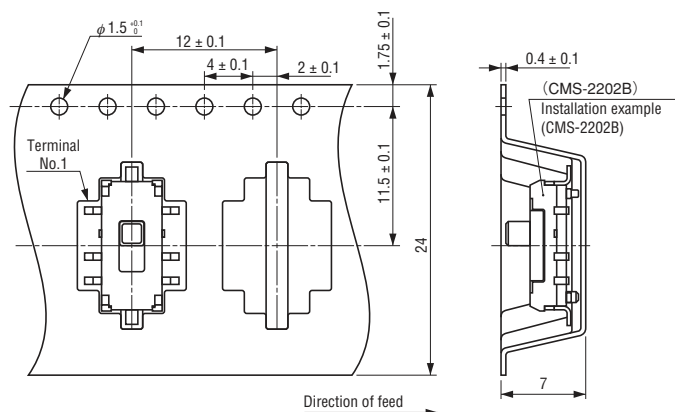

CMS

SLIDE SWITCHES (SMD)

● CMS-2302TA, TB

(Conforms to JIS C 0806)

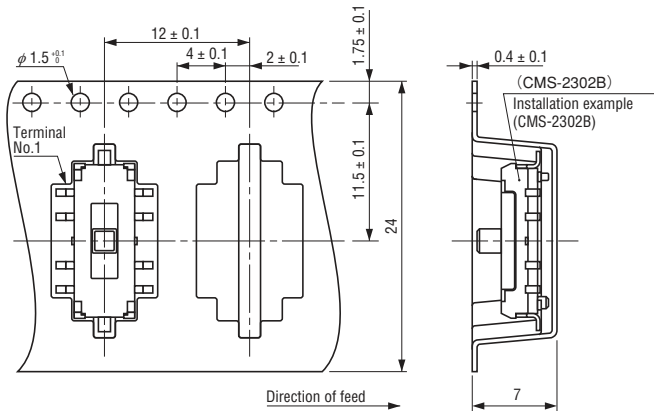

● CMS-2402TA, TB

(Unit : mm)
(Conforms to JIS C 0806)

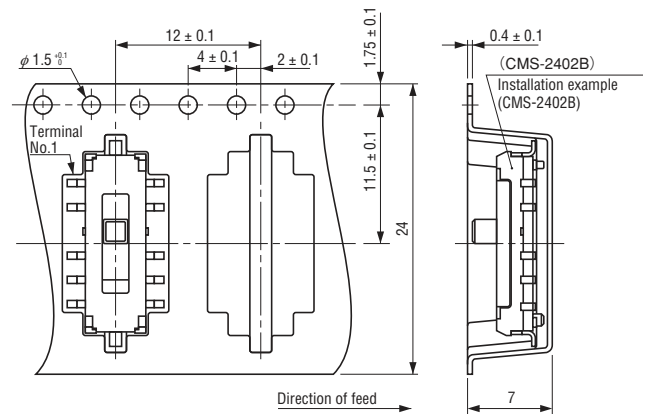

● CMS-2212 • 2214TA, TB

(Conforms to JIS C 0806)

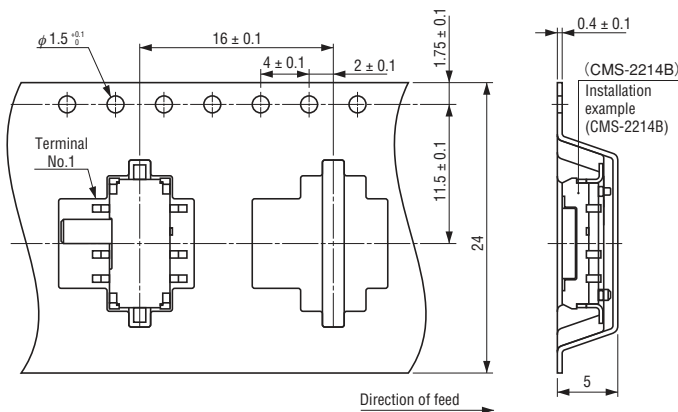

● CMS-2312 • 2314TA, TB

(Conforms to JIS C 0806)

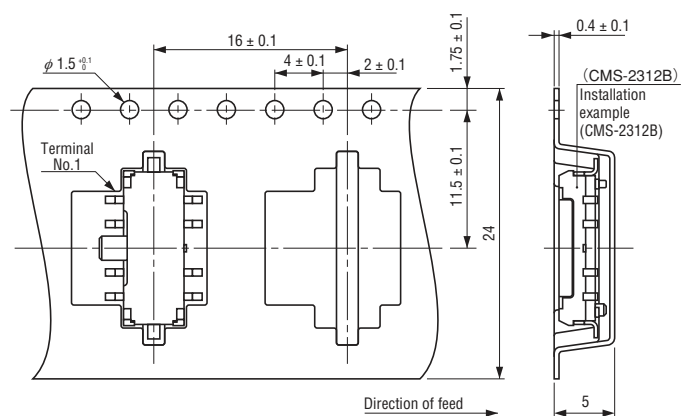

● CMS-2412 • 2414TA, TB

(Conforms to JIS C 0806)

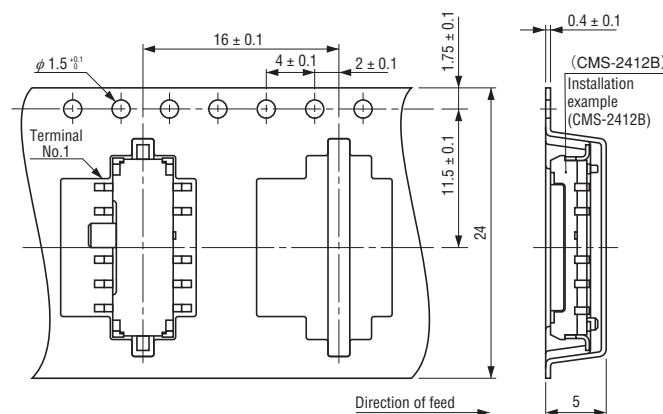

● CMS-4202TA, TB

(Conforms to JIS C 0806)

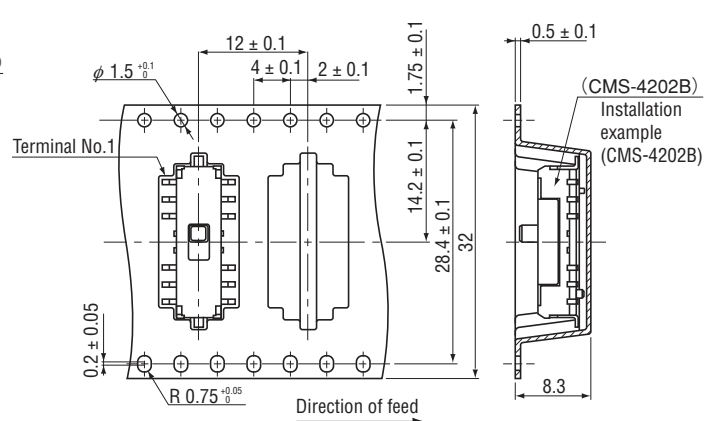

● CMS-4216TA, TB

(Unit : mm)
(Conforms to JIS C 0806)

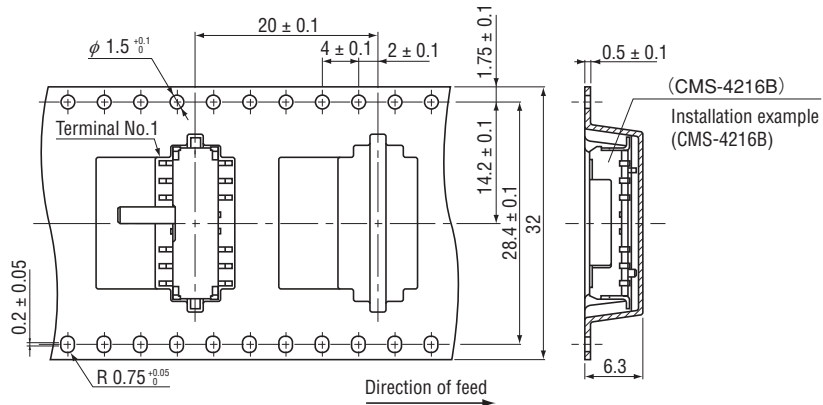

<Tray packaging specifications>

- Tray version is packaged in 50 pcs. per tray. Orders will be accepted for units of 50 pcs., i. e., 50, 100, 150 pcs. etc.
- Tray version is boxed with 10 trays.

<Bulk pack specifications>

- The smallest unit of bulk pack in a plastic bag is 10 pcs. per pack.
Orders will be accepted for unit of minimum 10 pcs., i.e., 10, 20, 30 pcs., etc.
- Boxing of bulk in plastic bag is performed with 50 pcs. (standard 100 pcs. / CMS-2 □□□□ , 50 pcs. / CMS-4 □□□□) per box.