

REV.	DATE	ECR NO.	DESCRIPTION
A	01/26/00	-	UPDATE DRAWING FORMAT
B	05/02/07	-	REVISE BARREL AND FERRULE DIMENSIONS
C	01/12/09	-	REVISE CABLE CALL OUT IN PART DESCRIPTION.

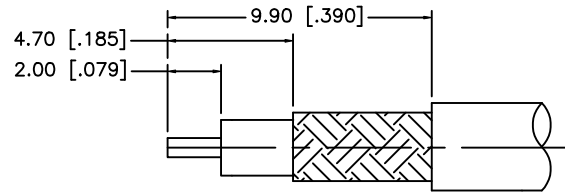

RECOMMENDED  
CABLE STRIPPING DIM'S

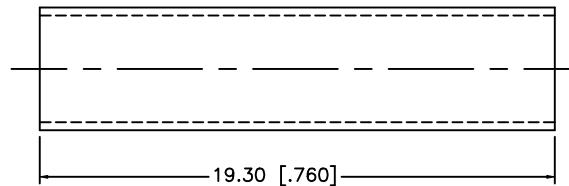
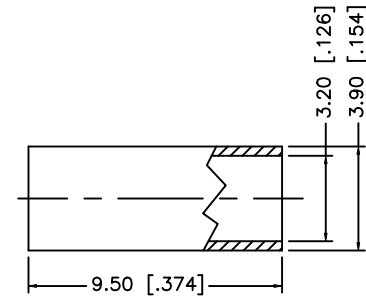
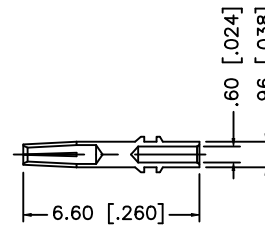
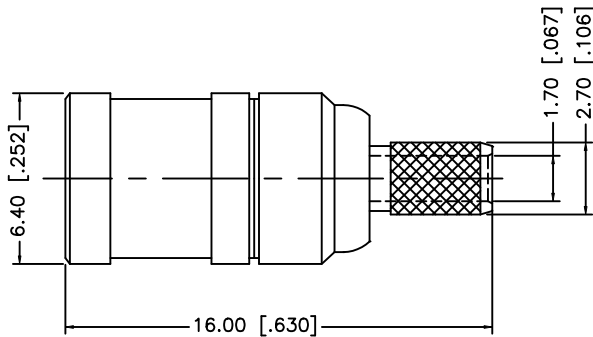

NOTE:

1. CRIMPED FERRULE HEX CRIMP SIZE .128" [3.25]
2. CONTACT PIN TO SOLDER.

DESCRIPTION	MATERIAL	FINISH	QTY	DO NOT SCALE DRAWING	APPROVALS	DATE	Amphenol Connex							
8				<small>UNLESS OTHERWISE SPECIFIED DIMENSIONS ARE IN MILLIMETERS. DIMENSIONS IN [ ] ARE IN INCHES AND FOR CUSTOMER REFERENCE ONLY.</small> <small>UNLESS OTHERWISE SPECIFIED TOLERANCES FOR MILLIMETERS ARE:</small> 0.5 - 8mm ± 0.20mm 8 - 30mm ± 0.40mm 30 - 120mm ± 0.50mm <small>UNLESS OTHERWISE SPECIFIED TOLERANCES FOR INCHES ARE:</small> .020 - .315 = ± 0.007" .315 - 1.180 = ± 0.015" 1.180 - 4.724 = ± 0.020"	DRAWN	G.R.S.	01/12/09	<b>MINI SMB CRIMP PLUG - 75 ohm (FOR RG-179/187 CABLE)</b>						
7			CHECKED				PART DESCRIPTION							
6			ISSUED				PART NO.							
5	HEAT SHRINK TUBE	BLACK	1		SHEET	1 OF 1		142178-75						
4	FERRULE	COPPER	NICKEL		1			DWG. NO. 142178-75.DWG						
3	CONTACT PIN	BER. COPPER	GOLD		1			REV. C						
2	INSULATOR	PTFE	NATURAL		1			SIZE A						
1	BODY	BRASS	NICKEL		1			SCALE NA						
					CAD FILE		C:/142/142178-75.DWG							