

APPROVAL SHEET



WLSSA50G Series
Shielded SMD Power Inductors

*Contents in this sheet are subject to change without prior notice.

Features

1. Shielded power inductor.
2. Wide inductance range.

Applications

1. Inductor in DC/DC converter.
2. Use in STB、PDA、Notebook.

Shape and Dimension

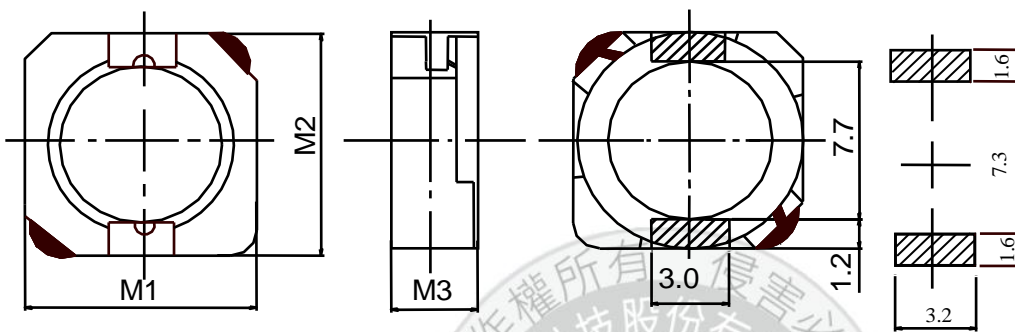

	DIM.	TOL.
M1	10.3	MAX.
M2	10.5	MAX.
M3	5.1	MAX.

Unit : mm

Ordering Information

WL	SS	A50G	Z0	N	1R5	L	B
Product Code	Series	Dimensions	Series extension	Tolerance	Value	Packing Code	
WL: Inductor	Shielded SMD Power Inductors	10.3 * 10.5 mm	Z0:STD	N: ±30%	R80 = 0.8uH 1R5 = 1.5uH 100 = 10.0uH 101 =100uH 102 =1000uH	L=13" Reeled (Embossed tape)	B:STD

Electrical Characteristics

WLSSA50G Series	Marking	L (uH)	Inductance Tolerance	Test Freq (KHz)	DCR (mΩ) MAX.	I sat (A)	Rated Current (A)
WLSSA50GZ0NR80LB	R80	0.8	±30%	100	4.3	13.5	9.5
WLSSA50GZ0N1R5LB	1R5	1.5	±30%	100	5.8	10.5	8.3
WLSSA50GZ0N2R2LB	2R2	2.2	±30%	100	7.2	9.25	7.5
WLSSA50GZ0N3R3LB	3R3	3.3	±30%	100	10.4	7.80	6.5
WLSSA50GZ0N4R7LB	4R7	4.7	±30%	100	12.3	6.4	6.1
WLSSA50GZ0N6R8LB	6R8	6.8	±30%	100	18.0	5.4	5.4
WLSSA50GZ0N8R2LB	8R2	8.2	±30%	100	20	4.85	5.0
WLSSA50GZ0N100LB	100	10	±30%	100	26	4.45	4.5
WLSSA50GZ0N120LB	120	12	±30%	100	33	4.0	3.8
WLSSA50GZ0N150LB	150	15	±30%	100	41	3.6	3.4
WLSSA50GZ0N180LB	180	18	±30%	100	46	3.2	3.1
WLSSA50GZ0N220LB	220	22	±30%	100	61	2.95	2.9
WLSSA50GZ0N270LB	270	27	±30%	100	69	2.7	2.6
WLSSA50GZ0N330LB	330	33	±30%	100	84	2.4	2.5
WLSSA50GZ0N390LB	390	39	±30%	100	106	2.3	2.25
WLSSA50GZ0N470LB	470	47	±30%	100	130	2.0	2.0
WLSSA50GZ0N560LB	560	56	±30%	100	149	1.9	1.9
WLSSA50GZ0N680LB	680	68	±30%	100	201	1.65	1.6
WLSSA50GZ0N820LB	820	82	±30%	100	227	1.5	1.45
WLSSA50GZ0N101LB	101	100	±30%	100	253	1.35	1.35
WLSSA50GZ0N121LB	121	120	±30%	100	303	1.28	1.18
WLSSA50GZ0N151LB	151	150	±30%	100	370	1.12	1.1
WLSSA50GZ0N181LB	181	180	±30%	100	419	1.04	1.0
WLSSA50GZ0N221LB	221	220	±30%	100	500	0.94	0.94
WLSSA50GZ0N271LB	271	270	±30%	100	672	0.84	0.8
WLSSA50GZ0N331LB	331	330	±30%	100	812	0.75	0.73
WLSSA50GZ0N391LB	391	390	±30%	100	953	0.7	0.7
WLSSA50GZ0N471LB	471	470	±30%	100	1289	0.6	0.54
WLSSA50GZ0N561LB	561	560	±30%	100	1430	0.54	0.52
WLSSA50GZ0N681LB	681	680	±30%	100	1599	0.52	0.51
WLSSA50GZ0N821LB	821	820	±30%	100	1768	0.5	0.48
WLSSA50GZ0N102LB	102	1000	±30%	100	1989	0.48	0.42

- a. Tolerance : N : $\pm 30\%$
- b. Operating Temp : -25°C to $+105^{\circ}\text{C}$.
- c. Inductance measured using the HP4284A LCR meter, CHROMA1320 & 3302 & 16502.
- d. DCR measured using the 502BC milli-ohm meter.
- e. Inductance drops no more than 35% of initial value at Isat ,temperature rises $\Delta t < 30^{\circ}\text{C}$ at rated current.
- f. MSL : LEVEL 1

TYPICAL RoHS REFLOW PROFILE

Typical RoHS Reflow Profile

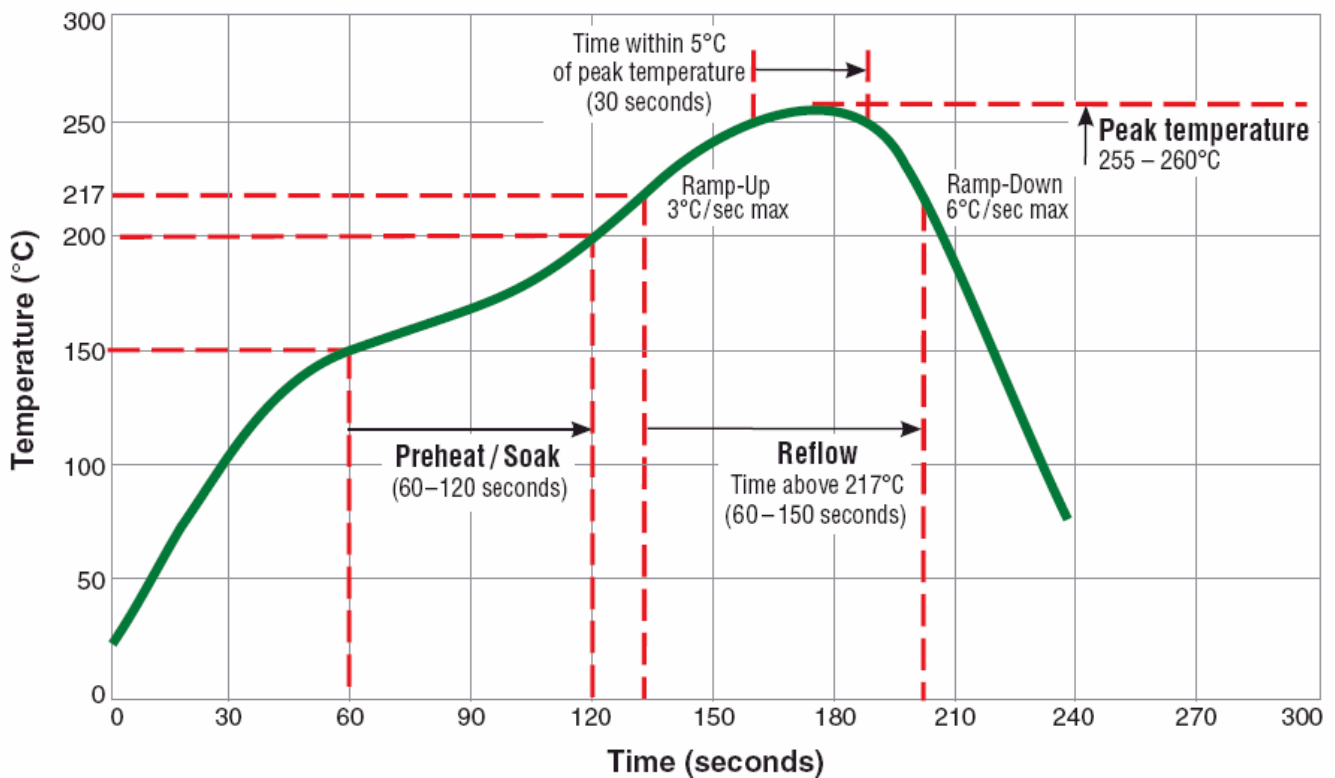

RELIABILITY PERFORMANCE

Reliability Experiment For Electrical

Test Item	Test Condition	Standard Source
Humidity Test	+40°C ± 2°C, humidity of 90% ± 5% (total 96 hours).	MIL-STD-202G Method 103B Test Condition B
High Temperature Test	1. Temperature: +125°C ± 2°C 2. Test time: 48 ± 2hrs	IEC 68-2 Test Condition B
Low Temperature Test	1. Temperature: -40°C ± 2°C 2. Test time: 48 ± 2hrs	IEC 68-2 Test Condition A
Thermal Shock	+125°C ± 5°C (30 minutes) ~ -40 ± 5°C (30 minutes), temperature switch time: 5 minutes (total 50 cycles).	MIL-STD-202G Method 107G Test Condition B-2
Life Test	+70°C ± 5°C (250Hours)	MIL-STD-202G Method 108A Test Condition B

Reliability Experiment For Physical

Test Item	Test Condition	Standard Source
Vibration Test	10-55-10HZ, amplitude: 1.5mm, direction: X, Y, Z axes, each axis 2 hours (total 6 hours).	MIL-STD-202G Method 201A
Solder Heat Resistance Test	IR/convection reflow: Peak Temp 250 ± 5°C for 5Sec in air, Through 2 Cycle. Temperature Ramp: +1~4°C/sec; Above 183°C, must keep 90 s - 120 s	MIL-STD-202G Method 210F Test Condition (Reflow)
Solder Ability Test	Soak in 245 °C solder pot of 3Sec, PAD must have 95% above coverage.	J-STD-003B

Tape & Reel Packaging Dimensions:

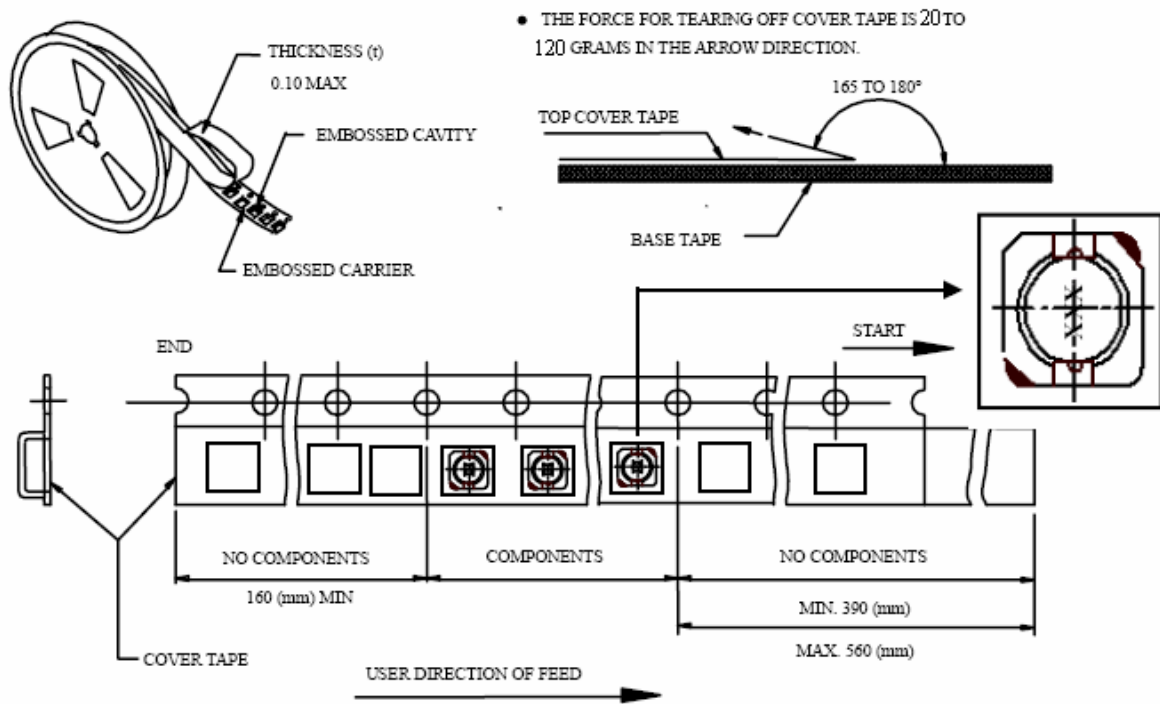

■ CARRIER TAPE REELS (mm)

MATERIAL: PLASTIC

■ DIMENSIONS OF CARRIER TAPE (mm)

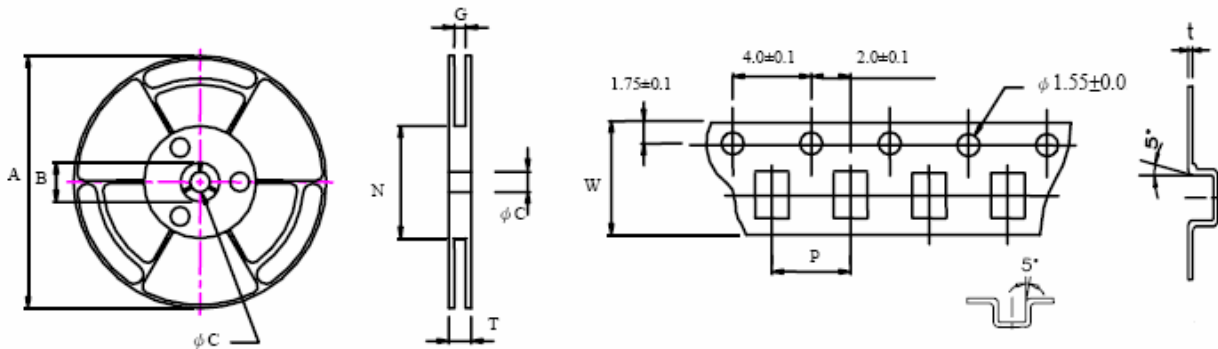

Unit : mm

	A	B	C	G	N	P	T	W	t
DIM.	340	20.2	13.0	24.4	100	16.0	30.5	24	0.35
TOL.	MAX	MIN	±0.5	±2.0	MIN	±0.1	MAX	±0.3	±0.05

Quantity per reel : 500 pcs