



## Multilayer Low Pass Filter

For 1880-2025MHz

DEA Series 1.6x0.8mm [EIA 0603] TYPE

P/N: **DEA162025LT-5046C1**

## DEA162025LT-5046C1

### ■ SHAPES AND DIMENSIONS

[Top View]

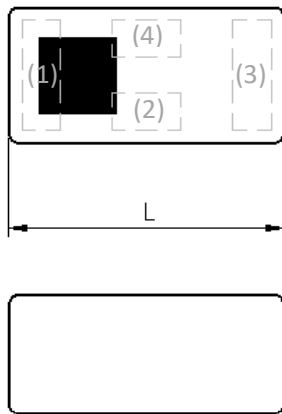

[Bottom View]

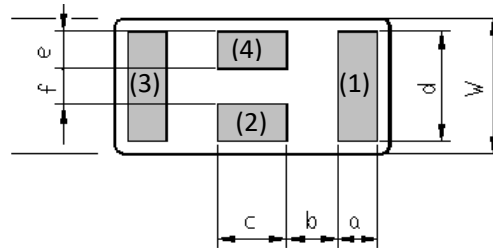

Dimensions (mm)

L	W	T	a	b	c	d	e	f
1.60	0.80	0.60	0.225	0.30	0.40	0.65	0.22	0.21
+/-0.10	+/-0.10	+/-0.10	+/-0.05	+/-0.05	+/-0.05	+/-0.05	+/-0.05	+/-0.05

Terminal functions

(1)	Input / Output Port
(2)	GND
(3)	Output / Input Port
(4)	GND

### ■ TERMINATION FINISH

Material
Au plate

## DEA162025LT-5046C1

### ■ ELECTRICAL CHARACTERISTICS

( Measurement )

Parameter	Frequency (MHz)	TDK Spec		
		Min.	Typ.	Max.
Insertion Loss (dB)	1880 to 2025	-	1.00	1.35
Insertion Loss (dB) ( -40 to +90 °C )	1880 to 2025	-	-	1.50
VSWR (Input Port)	1880 to 2025	-	1.2	1.7
VSWR (Output Port)	1880 to 2025	-	1.2	1.7
Attenuation (dB)	2400 to 2500	25	29	-
	3760 to 4050	27	31	-
	5150 to 5850	30	33	-
	5640 to 6075	27	30	-
	7520 to 8100	17	21	-
	9400 to 10125	12	17	-
Characteristic Impedance (ohm)		50 (Nominal)		

Ta = +25+/-5°C

### ■ MAXIMUM RATINGS

Parameter	TDK Spec	Conditions
Operating temperature (°C)	-40 to +90 °C	
Storage temperature (°C)	-40 to +90 °C	
Power Handling (dBm)	30	CW
Human Body Model : HBM @Each Port (V)	+/-1000	100pF / 1500ohm
Machine Model : MM @Each Port (V)	+/-150	200pF / 0ohm
Charged Device Model : CDM @Each Port (V)	+/-500	Humidity : 60%RH max

\*1 : Refer to 3GPP TS 38.101-1 V15.2.0

# DEA162025LT-5046C1

## FREQUENCY CHARACTERISTICS

Insertion Loss

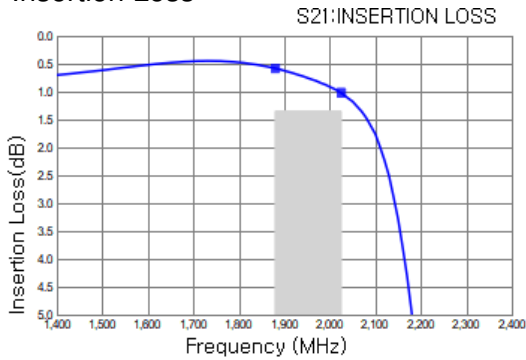

Attenuation

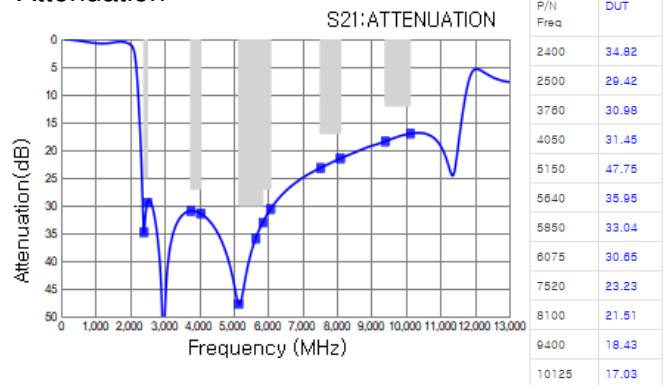

VSWR (Input Port)

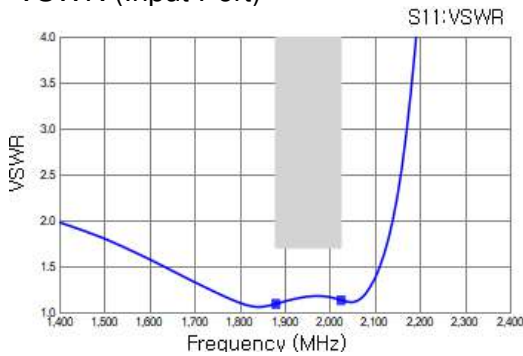

Smith Chart (Input Port)

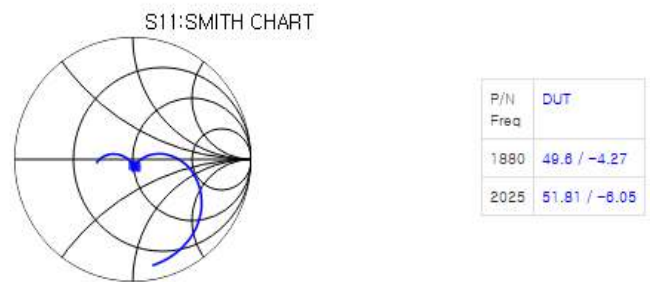

VSWR (Output Port)

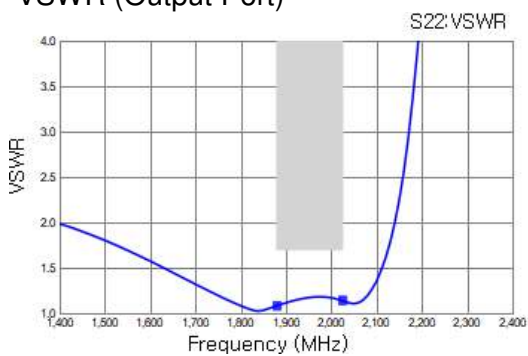

Smith Chart (Output Port)

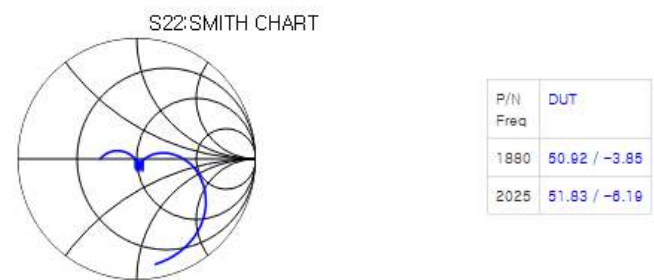

## DEA162025LT-5046C1

### RECOMMENDED LAND PATTERN

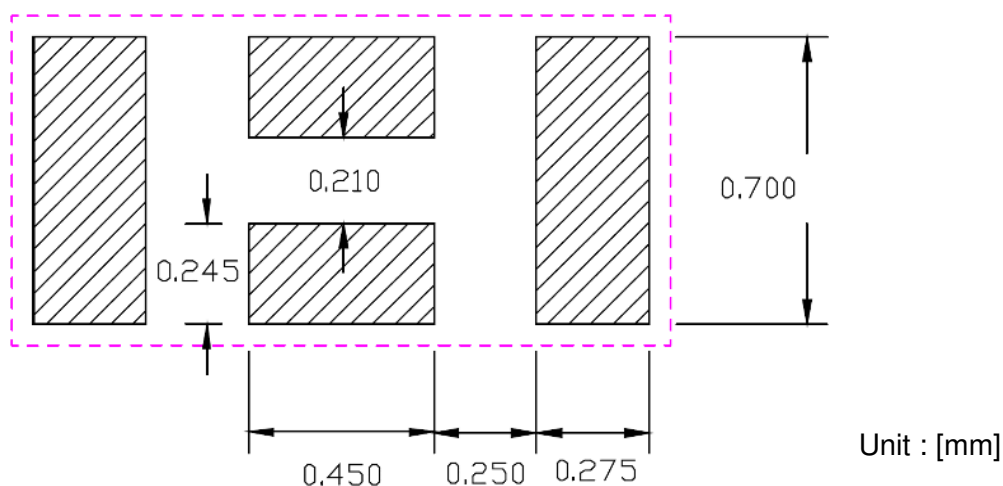

### EVALUATION BOARD

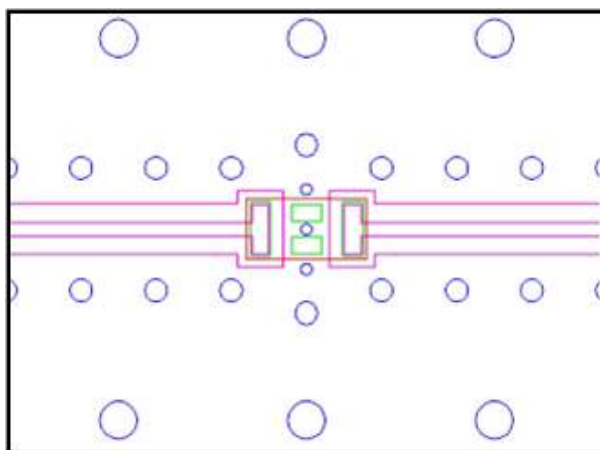

- Thru hole
- Resist
- Surface Pattern
- DUT (LPF)

Material & Layer	Thickness
Top Resist	-
Copper Surface Pattern	0.035 mm
FR-4	0.10 mm
Inner GND	0.018 mm
FR-4	0.30 mm
Copper Bottom GND	0.035 mm

\* Line width should be designed to match 50 ohm characteristic impedance depending on PCB material and thickness.

### ENVIRONMENT INFORMATION

RoHS Statement  
RoHS Compliance

## DEA162025LT-5046C1

### RECOMMENDED REFLOW PROFILE

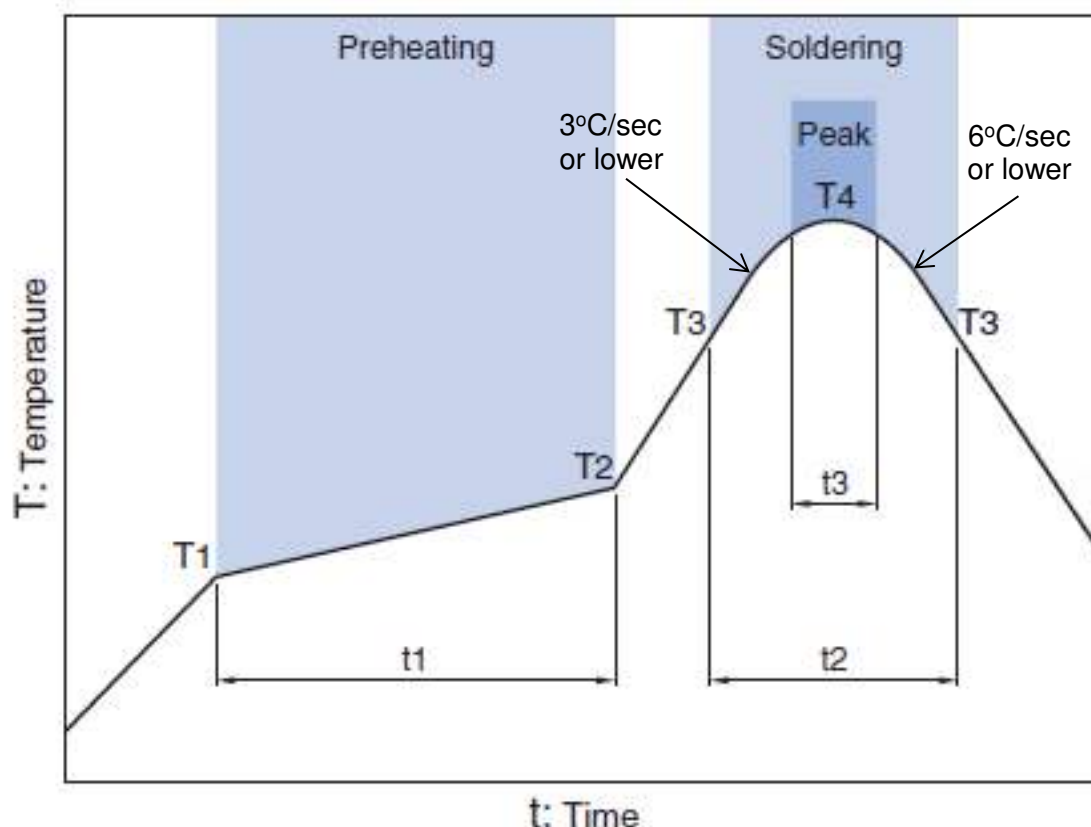

Preheating			Soldering			
Temp.		Time	Critical zone (T3 to T4)		Peak	
T1	T2	t1	T3	t2	T4	t3 *
150°C	200°C	60 to 120sec	217°C	60 to 120sec	240 to 260°C	30 sec Max

\* t3 : Time within 5°C of actual peak temperature

The maximum number of reflow is 3.

Note: Lead free solder is recommended.  
Recommended solder is Sn-3.0Ag-0.5Cu. (M705 by Senju Metal Industry)

### GENERAL TECHNICAL INFORMATION

[https://product.tdk.com/en/system/files?file=dam/doc/product/rf/rf/coupler/general\\_tech\\_info/rf\\_general-technical-info\\_02\\_en.pdf](https://product.tdk.com/en/system/files?file=dam/doc/product/rf/rf/coupler/general_tech_info/rf_general-technical-info_02_en.pdf)

**DEA162025LT-5046C1****PACKAGING STYLE**

## Reel Dimensions

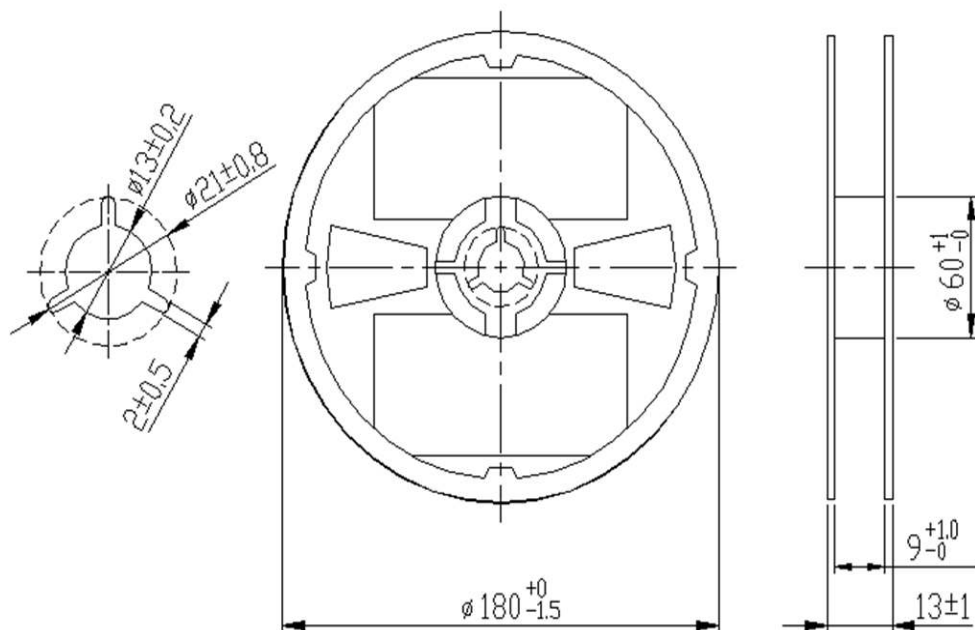

Dimensions in mm

## Carrier Tape

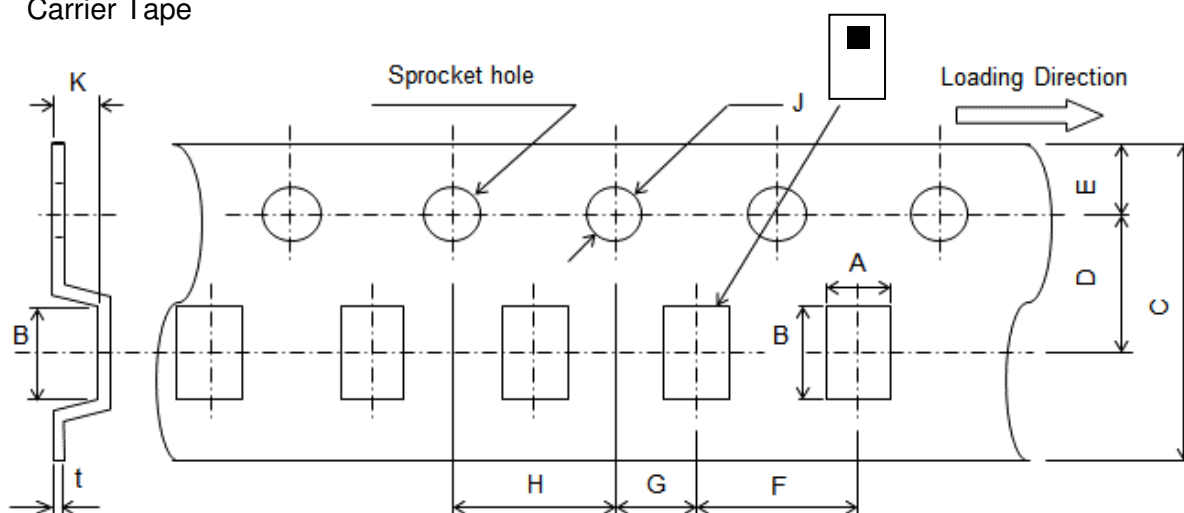

## Dimensions (mm)

A	B	C	D	E	F	G	H	J	K	t
0.97	1.8	8.0	3.5	1.75	4.0	2.0	4.0	1.5	0.8	0.25
+/-0.05	+/-0.05	+/-0.2	+/-0.05	+/-0.1	+/-0.1	+/-0.05	+/-0.1	+0.1/-0	MAX	+/-0.05

**STANDARD PACKAGE QUANTITY****( pieces/reel )**

4,000

## REMINDERS FOR USING THESE PRODUCTS

Before using these products, be sure to request the delivery specifications.

### SAFETY REMINDERS

Please pay sufficient attention to the warnings for safe designing when using these products.

#### REMINDERS

The products listed on this catalog are intended for use in general electronic equipment (AV equipment, telecommunications equipment, home appliances, amusement equipment, computer equipment, personal equipment, office equipment, measurement equipment, industrial robots) under a normal operation and use condition.

The products are not designed or warranted to meet the requirements of the applications listed below, whose performance and/or quality require a more stringent level of safety or reliability, or whose failure, malfunction or trouble could cause serious damage to society, person or property.

Please understand that we are not responsible for any damage or liability caused by use of the products in any of the applications below or for any other use exceeding the range or conditions set forth in this catalog.

- |                                                                   |                                                                              |
|-------------------------------------------------------------------|------------------------------------------------------------------------------|
| (1) Aerospace/Aviation equipment                                  | (8) Public information-processing equipment                                  |
| (2) Transportation equipment (cars, electric trains, ships, etc.) | (9) Military equipment                                                       |
| (3) Medical equipment                                             | (10) Electric heating apparatus, burning equipment                           |
| (4) Power-generation control equipment                            | (11) Disaster prevention/crime prevention equipment                          |
| (5) Atomic energy-related equipment                               | (12) Safety equipment                                                        |
| (6) Seabed equipment                                              | (13) Other applications that are not considered general-purpose applications |
| (7) Transportation control equipment                              |                                                                              |

When using this product in general-purpose applications, you are kindly requested to take into consideration securing protection circuit/equipment or providing backup circuits, etc., to ensure higher safety.