

# HERMETICALLY SEALED MICROSWITCH TYPES 83 151 (-55 °C TO 150 °C)

## BASIC CELL

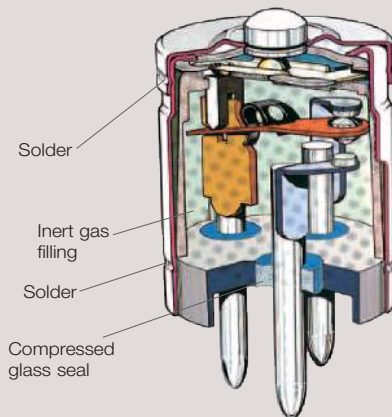

This is the basic component for our whole range of standard 1-pole and 2-poles hermetically-sealed limit switches plus the 3-poles version (special Limit Switches).

The Crouzet Aerospace hermetic microswitch combines a snap-action switching system with high resistance to shock and vibration in an hermetically sealed miniature case which encloses an atmosphere of inert gas around its contacts, ideal for switching very low level circuits and higher currents also.

The meticulous care taken in the manufacture of this hermetically sealed cell in terms of assembly processes, cleanliness of components as well as inspection procedures, result in a product which is ideal for operation in severe environments where a high level of reliability is essential.

The Crouzet Aerospace hermetically sealed cell is particularly well suited to sectors such as Aerospace, Armaments, Marine, Nuclear, etc.

## ESSENTIAL CHARACTERISTICS

- › Switching power from 1 mA to 7 A.
- › Operating temperature: -55 °C to +150 °C (Type 83 151 2: -55 °C to +250 °C).
- › Vibration resistant up to 80 G.
- › Shock resistant up to 200 G.
- › High level of hermetic sealing: Leakage <  $1 \times 10^{-6}$  cm<sup>3</sup> He/s
- › Long life: 200 000 cycles.
- › Small size:  $\varnothing 11 \times 16$ .
- › Numerous single pole and multipoles operating and fixing options.

## DISTINCTIVE CHARACTERISTICS

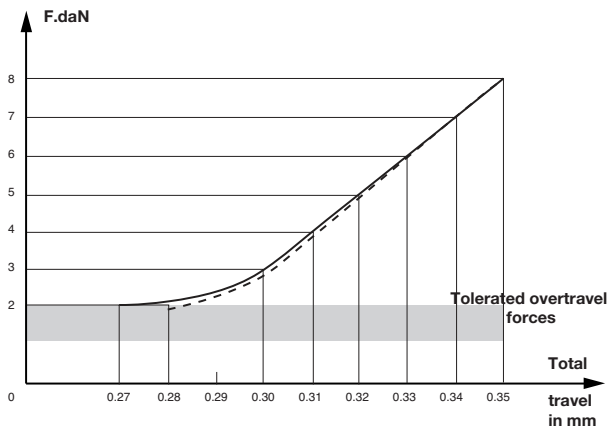

### Mechanical strength

There is no sudden increase in the total travel of the detector when overtravel forces rising to as much as 80 N are applied. If, after doing this, the overtravel force is altered back to its normal level of 20 N with the same detector, only a very slight change will be apparent in the total travel (low remanence).

The detector will suffer damage if the overtravel force is raised to as much as 150 N.

### Hermetic sealing

- › The microswitch is filled with inert gas (nitrogen-hydrogen mixture), the internal pressure being 1 bar.
- › The hermetic sealing (membrane-cap - cap-base) is achieved with a continuous seam welding bead.

Performance in qualification helium test condition. Qualification value:  $1 \times 10^{-8}$  atm cm<sup>3</sup>/s.

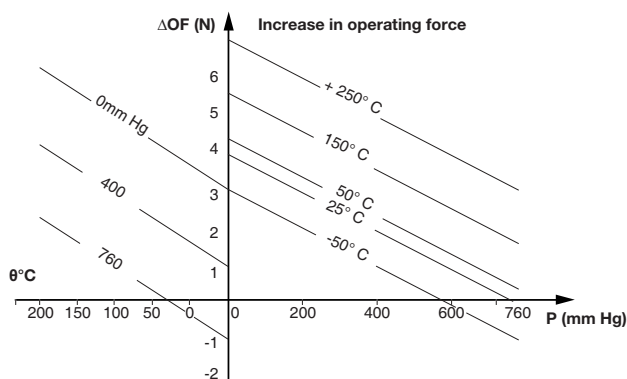

### Change in operating force as a function of temperature and ambient pressure.

The force levels required to operate our hermetically sealed microswitches are affected by ambient pressure and temperature.

Here we give a graph showing how the operating force increases ( $\Delta OF$ ) as a function of these two parameters.

The characteristics are given for standard temperature (23 °C) and atmospheric pressure at sea level (760 mm Hg).

Our hermetically sealed microswitches can be used at pressures ranging from atmospheric to absolute vacuum and there are variants for use at higher pressures.

# HERMETICALLY SEALED MICROSWITCH TYPES 83 151 (-55 °C TO 150 °C)

## Reliability of characteristics

Below are two test extracts showing the stability of the essential characteristics over time and as a function of temperature.

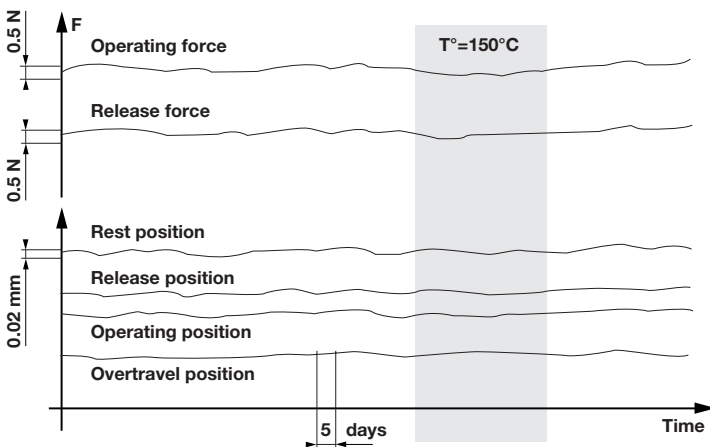

### Travels and forces

Change in the characteristics concerned under a constant load of 25 Newtons applied to the operating device.

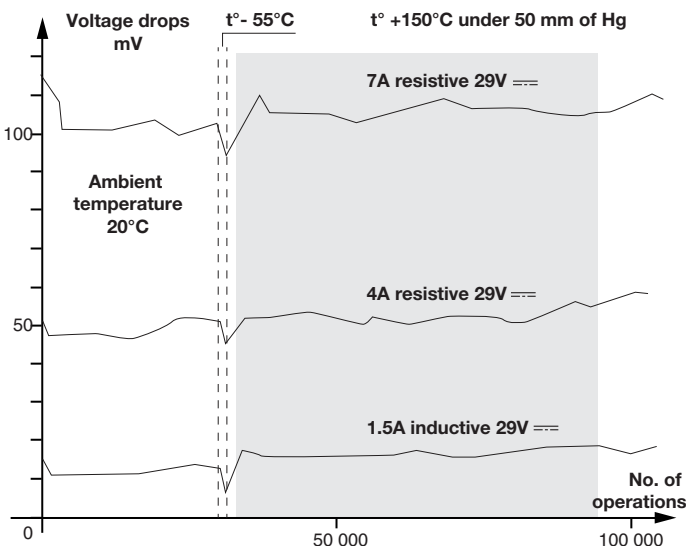

### Voltage drops

Change in this characteristic in accordance with Air 8459 method - for 1.5-4 and 7 Amp load.

# CONNECTIONS

Electrical connections are made through the base, by three ferronickel terminals, with copper core, sealed by compressed glass.

## Soldered

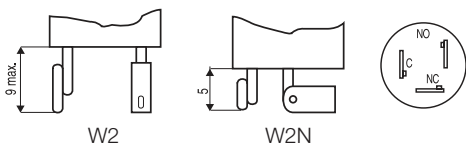

## Wired

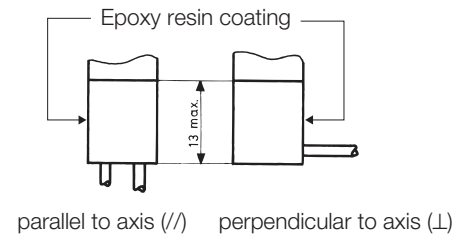

## Electrical diagram (actuator at rest position)



## Dimensions (mm)

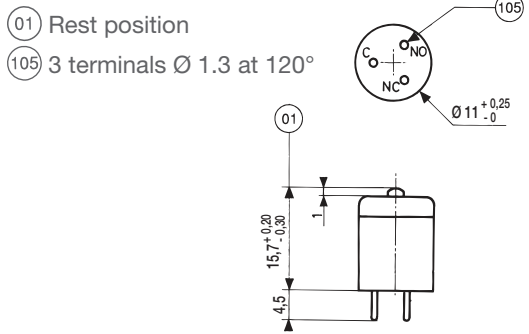

Wires: 0.38 mm<sup>2</sup> Air 4524 - length 0.50 m.  
 Category 140°C 170°C.

# PERFORMANCE DATA

Product characteristics	Value	Unit	Under
Min. Current	1	mA	5 V DC
Nominal Current			
Resistive	3	A	48 V DC <sup>(1)</sup>
Lamp	1	A	115 V - 400 Hz
Lamp	2	A	30 V DC <sup>(1)</sup>
Resistive	3	A	30 V DC <sup>(1)</sup>
Inductive L/R = 0.005 s	1.5	A	30 V DC <sup>(1)</sup>
Resistive	1	A	220 V AC
Inductive - cos φ 0.8	0.4	A	220 V AC
	200 000	Cycles	
Dielectric rigidity between connections and ground	1 200	V	
Rigidity between connections	1 000	V	
Insulation resistance (at 500 V DC)	100	MΩ	
Voltage drop at 1 A <sup>(2)</sup>	0.02	V	
Operating temperature	-55 to +150	°C	
Shock resistance <sup>(3)</sup>	200/11	G/ms	
Vibration resistance	80/20 → 2 000	G/Hz	

(1) for a service life of 100 000 cycles - Permitted current 4 A inductive 7 A resistive for normally open or normally closed contacts.  
 (2) Over soldered connections - for wired connections add 0.1 V per meter.  
 (3) Value for microswitch without auxiliary actuator

# HERMETICALLY SEALED MICROSWITCHES WITH ACCESSORIES

## BASIC CELL (-55°C TO +150°C) TYPE 83 151 001

Criteria	Connections	with lateral flange	with 90° flange	Threaded barrel fixing
Pole(s)		1	1	1
Soldered connections	W2	83 151 012	83 151 014	83 151 013
	W2N	83 151 042	83 151 044	83 151 043
Wire 0.38 mm <sup>2</sup> - 0.5 m long	with parallel wires	83 151 022	83 151 024	83 151 023
	with perpendicular wires	83 151 032	83 151 034	83 151 033

Characteristics	Unit			
Max. Operating force	N	10	10	10
Min. Release force	N	1.5	1.5	1.5
Permitted Overtravel force	N	20	20	20
Positive Overtravel stop				
Service life	Operations - min	200 000	200 000	200 000
Max. Pre-travel	mm	0.25	0.25	0.25
Max. Differential travel	mm	0.05	0.05	0.05
Min. Overtravel	mm	0.08	0.08	0.08
Weight (without wires)	g	5	5	13

### Dimensions (mm)

Add the dimensions of the various connections to find the total dimensions

► indicates the wire direction

① Tripping point

⑪ Nut h 2.5 x 17 / flat

### Panel cut-out

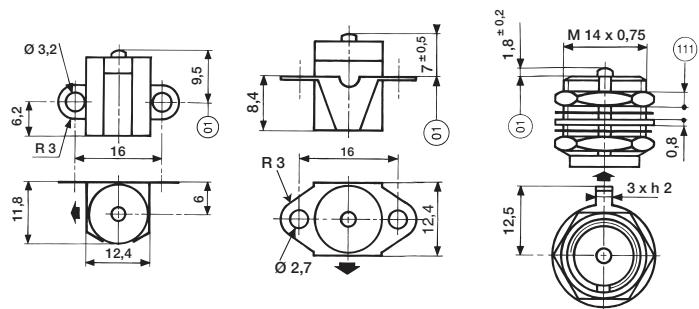
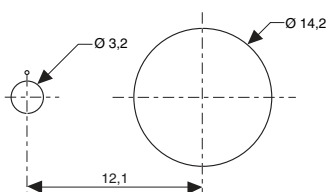

with lateral flange + lever	with lateral flange + roller lever	Housing + lever	with lateral flange + lever	with lateral flange + roller lever
1	1	1	2	2
83 560 011	83 560 012	83 560 014	83 560 311	83 560 312
83 560 041	83 560 042	83 560 049	83 560 341	83 560 342
83 560 021	83 560 022	83 560 030	83 560 321	83 560 322
83 560 031	83 560 032	83 560 039	83 560 331	83 560 332

5	5	2.5 → 8	15	15
0.5	0.5	1.5	1.5	1.5
		50		
		•		
100 000	100 000	100 000	100 000	100 000
6	6	0.3 → 0.75	6	6
0.8	0.8	0.3	1.5	1.5
0.4 → 0.8	0.4 → 0.8	0.3	0.4 → 0.8	0.4 → 0.8
6	7	21	12	13

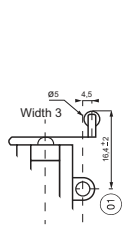
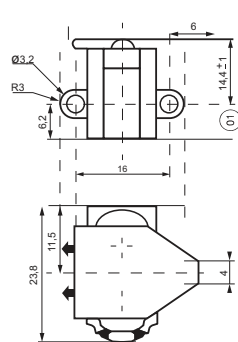
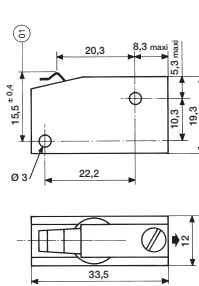
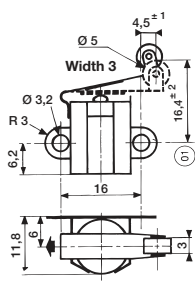
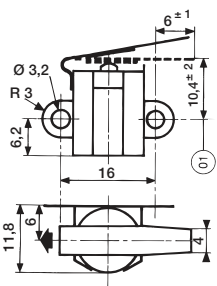
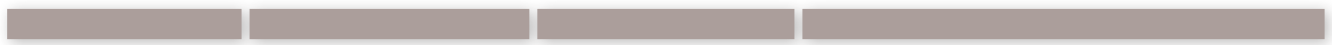

# HERMETICALLY SEALED MICROSWITCHES HIGH PRESSURE FROM 2 TO 6 BAR

## WITH BASIC CELL (-55 °C TO +150 °C)

These variants of the basic type 83 151 feature a compensating system which allow them to be used at pressures above atmospheric.

For other characteristics please refer to basic model type 83 151 0

Characteristics			
Permitted pressure	Bar	2	6
Max. Operating force *	N	25	47
Max. permitted Overtravel force *	N	45	80
Min. Release force *	N	11	22
Weight (without leads)	g	8,5	8,5

\* Figures at atmospheric pressure at ground level

### Dimensions (mm)

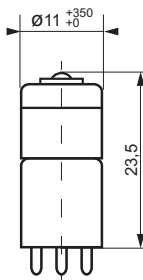

### Connections

W2 Ref. 83 151 504

W2N Ref. 83 151 503

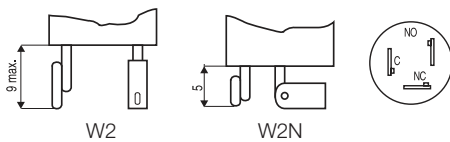

# HERMETICALLY SEALED MICROSWITCHES TYPES 83 151 (250 °C)

## WITHOUT ACCESSORIES (BASIC CELL -55°C TO +250 °C) TYPE 83 151 201

This basic component is the same design as the 83 151 001 standard cell but is adapted for operation in high temperatures up to 250°C.

Characteristics	Unit	Value
Nominal current at 30 VDC		
Resistive	A	1
Inductive L/R = 5 ms	A	1
Service life at nominal current	Min. operations	20 000/100 000
Voltage drop at 1 A <sup>(1)</sup>	V	0.06
Max. Operating force <sup>(2)</sup>	N	14
Min. Release force	N	1.5
Max. permitted Overtravel force	N	20
Max. Pre-travel	mm	0.25
Max. Differential travel	mm	0.05
Min. Overtravel	mm	0.08
Weight (without wires)	g	13

(1) On soldered connections. for wired connections add 0.18 V per meter. Category 250°, 280°.

(2) Characteristics at: θ = 250 °C atmospheric pressure at ground level.

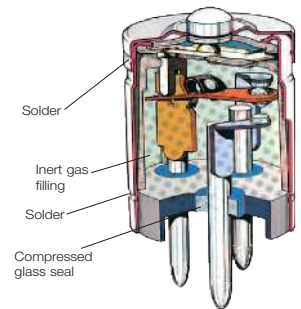

### Connections

with wires: 500 mm of length or soldered terminals

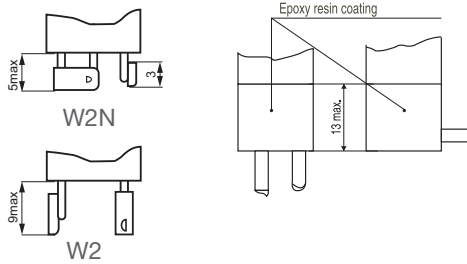

### Dimensions (mm)

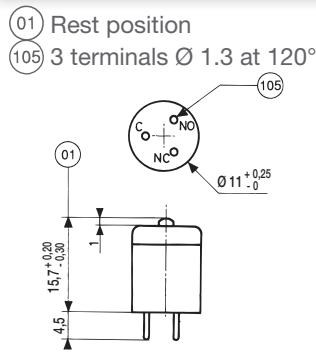

### Electrical diagram

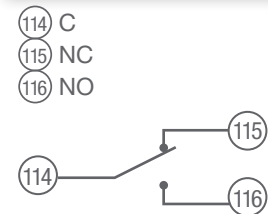

## WITH ACCESSORIES (BASIC CELL -55°C TO +250 °C) TYPE 83 151 201

Control accessories equipped with type 83 151 201 sensitive changeover

Criteria		
Pole(s)	1	1
W2 terminals output	83 151 212	83 151 213
// wires output	83 151 222	83 151 223
⊥ wires output	83 151 232	83 151 233
W2N terminals output	83 151 242	83 151 243
Weight (without wires)	6 g	13 g

Add the dimensions of the various connections for the total dimensions. The mechanical characteristics are those of the 83 151 201 changeover.

➤ indicates the direction of the wires.

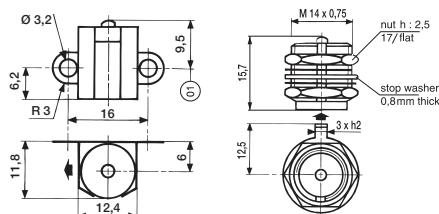

### Panel cut-out

