

# FMS CONNECTOR

1.0 mm pitch/Connectors for PC board/For FFC • Non-ZIF type

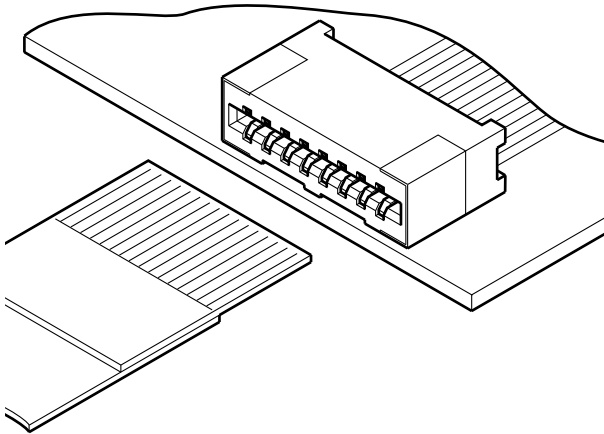

The FMS series connectors are designed for surface mounting (SMT) and to meet the demand for high-density packaging. They are miniature connectors with a height of only 2.8 mm, and can be supplied packaged in embossed tape to facilitate automatic mounting.

## ■ Features

### • Compact

This connector measures 1.0 mm in pitch, 2.8 mm in mounting height, and 6.3 mm in width.

### • Double-sided contact

This connector has highly resilient phosphor bronze contacts, each of which has two independent mating spring members that ensure continuity even when subjected to severe vibration. Because each of the contacts simultaneously mates with both sides of the FFC, the engineer has greater freedom in designing his circuitry.

### • Simple snap-in action

The FFC is securely connected by simply inserting its leads into the connector.

### • SMT configuration

Its housing is made of heat resistant resin so that it is not adversely affected during reflow soldering. Because of its tiny size and ability to be surface mounted, this connector meets the demand for high-density mounting of components inside electronic products.

### • Solder tabs

This connector also features reinforcing solder tabs to prevent lifting of the connector during mating and unmating.

## ■ Standards

Ⓜ : Recognized E60389

Ⓢ : Certified LR20812

## ■ Specifications

- Current rating: 0.5 A AC/DC
- Voltage rating: 50 V AC/DC
- Temperature range: -25°C to +85°C  
(including temperature rise in applying electrical current)
- Contact resistance: Initial value/20 mΩ max.  
After environmental tests/30 mΩ max.
- Insulation resistance: 800 MΩ min.
- Withstanding voltage: There shall be no breakdown or flashover while applying 500 VAC for one minute.
- Applicable FFC: Conductor pitch/1.0 mm  
Conductor width/0.7 mm  
Mating part thickness/0.30 ± 0.05 mm

\* In using the products, refer to "Handling Precautions for Terminals and Connectors" described on our website (Technical documents of Product information page).

\* RoHS2 compliance

\* Dimensional unit: mm

\* Contact JST for details.

# FMS CONNECTOR

## Connector

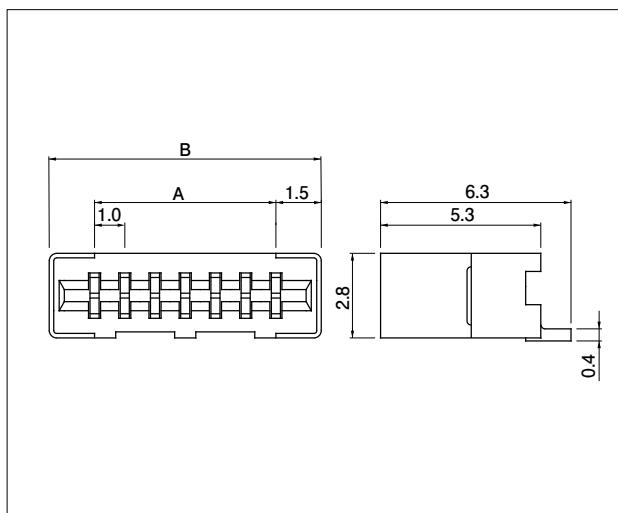

No. of circuits	Model No.	Dimensions (mm)		Q'ty / reel
		A	B	
3	03FMS-1.0SP-TF	2.0	5.0	2,500
4	04FMS-1.0SP-TF	3.0	6.0	2,500
5	05FMS-1.0SP-TF	4.0	7.0	2,500
6	06FMS-1.0SP-TF	5.0	8.0	2,500
8	08FMS-1.0SP-TF	7.0	10.0	2,500
10	10FMS-1.0SP-TF	9.0	12.0	2,000
12	12FMS-1.0SP-TF	11.0	14.0	2,000
14	14FMS-1.0SP-TF	13.0	16.0	2,000

Material and Surface finish, etc.

Contact: Phosphor bronze, copper-undercoated, tin-plated  
Housing: PPS, UL94V-0  
Solder tab: Brass, copper-undercoated, tin-plated

This product displays (LF)(SN) on a label.

Note: The products listed above are supplied on embossed tape.

## Dimensions of FFC lead section

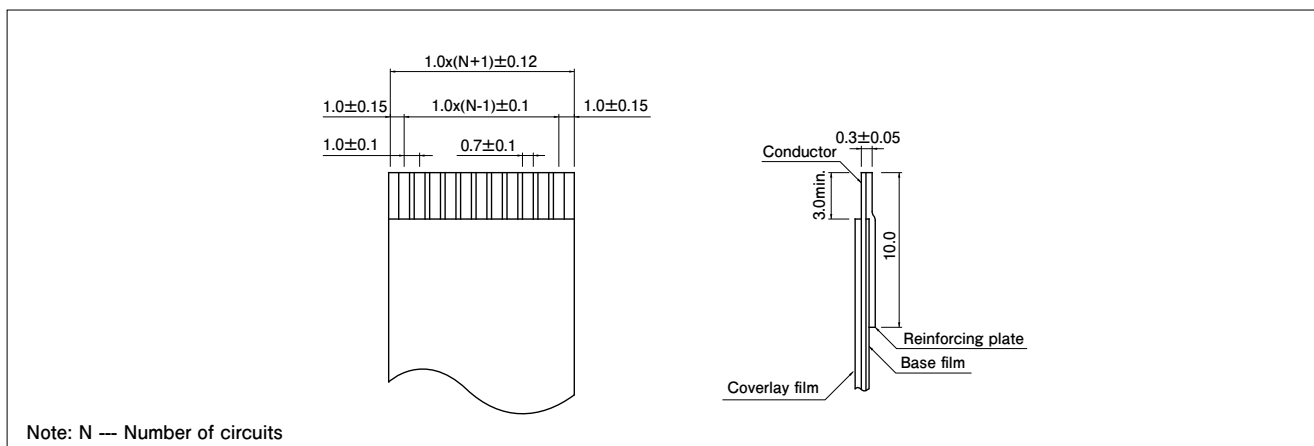

Note: N — Number of circuits

## PC board layout and Assembly layout

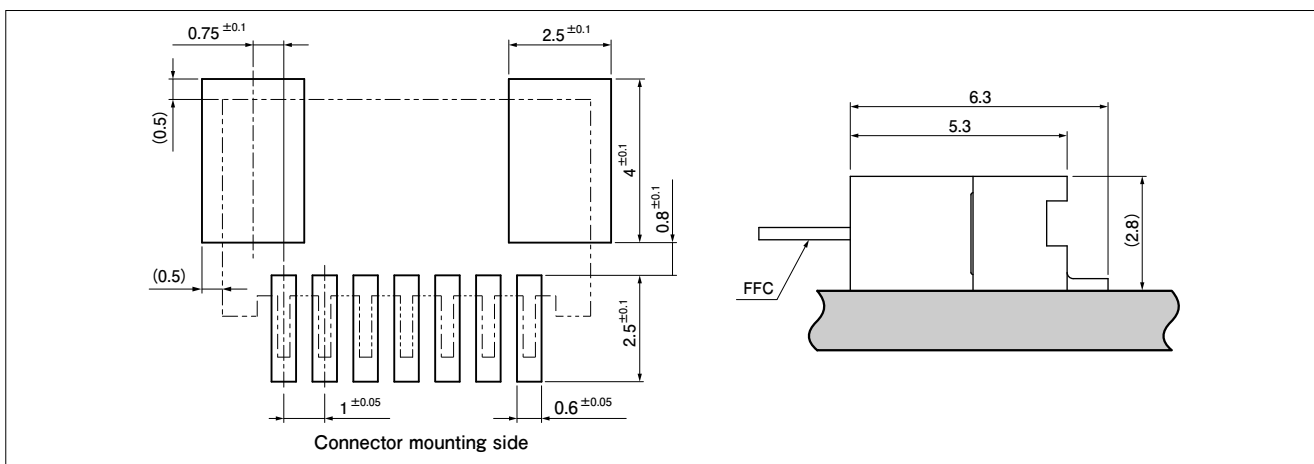

Note: 1. Tolerance for the PCB pattern pitch shall be  $\pm 0.05$  and shall not accumulate.  
2. The above dimensions are reference values. Please contact JST for details.