

PI3EQX1001

1-Channel USB3.1 GEN-2 ReDriver

Features

- 5 & 10Gbps serial link with linear equalizer.
- USB3.1 and USB3.0 Compatible
- Full Compliancy to USB3.1 Super Speed Standard
- Single 10Gbps differential signal pairs
- Pin Adjustable Receiver Equalization
- Pin Adjustable Flat Gain
- 100Ω Differential CML I/O's
- Automatic Receiver Detect
- Auto "Slumber" mode for adaptive power management
- Single Supply Voltage: 3.3V
- Packaging:
 - ◆ 18-pin, X2QFN 2x2 mm (XUA18)

Description

The PI3EQX1001 is a low power, high performance 10.0 Gbps 1-Channel USB 3.1 linear ReDriver™ designed specifically for the USB 3.1 protocol.

The device provides programmable equalization, and flat gain to optimize performance over a variety of physical mediums by reducing Inter-Symbol Interference. PI3EQX1001 supports one 100Ω Differential CML data I/O's between the Protocol ASIC to a switch fabric, over cable, or to extend the signals across other distant data pathways on the user's platform.

The integrated equalization circuitry provides flexibility with signal integrity of the signal before the ReDriver. The channels' input signal level determines whether the output is active.

The PI3EQX1001 also includes an automatic receiver detect function. The receiver detection loop will be active again if the corresponding channel's signal detector is idle for longer than 7.3mS. The channel will then move to Unplug Mode if load not detected, or it will return to Low Power Mode (Slumber Mode) due to inactivity.

Block Diagram

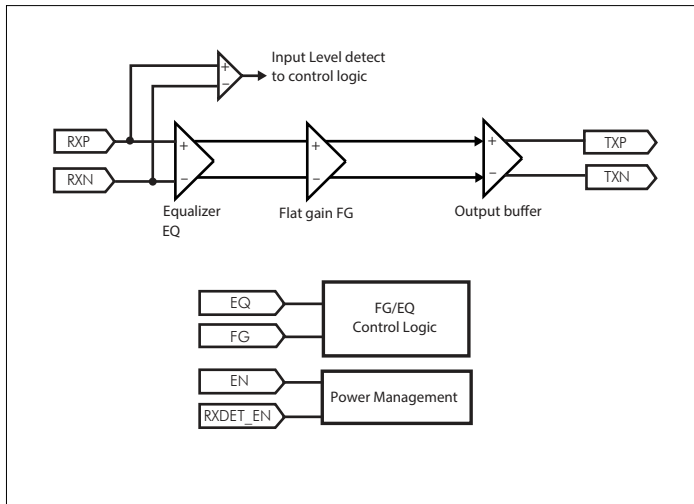
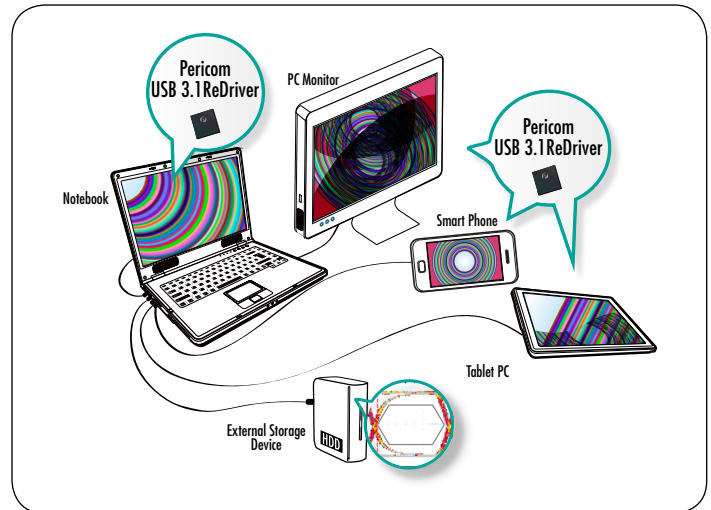
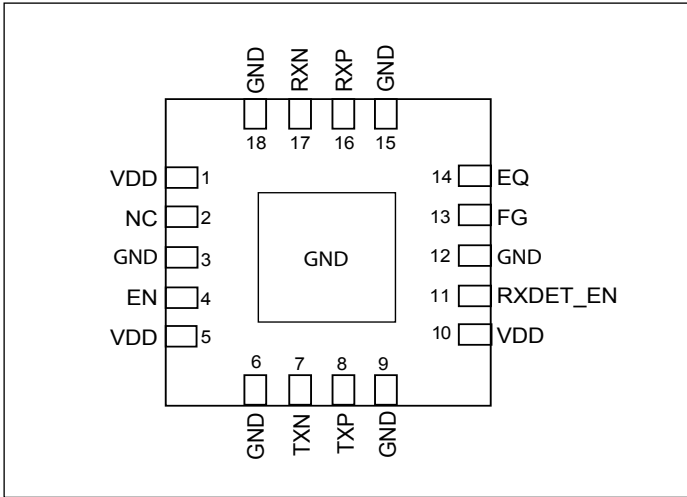

Figure 1



PI3EQX1001

Pin Diagram (18-pin, X2QFN 2x2mm) XUA18



Pin Description

Pin #	Pin Name	Type	Description
1, 5, 10	VDD	Power	3.3V power supply, +/-0.3V
13	FG	Input	The DC flat gain selection. 4-level input pins. With internal 100K Ω pull-up resistor and 200k Ω pull-down resistor.
14	EQ	Input	The EQ selection. 4-level input pins. With internal 100K Ω pull-up resistor and 200k Ω pull-down resistor.
16, 17	RXP, RXN	Input	CML input terminals. With selectable input termination between 50 Ω to VDD, 67k Ω to VbiasRx or 67k Ω to GND.
8, 7	TXP, TXN	Output	CML output terminals. With selectable output termination between 50 Ω to VDD, 4K to VDD, 4K to VbiasTx or Hi-Z
11	RXDET_EN	Input	Receiver detection Enable pin. With internal 300k Ω pull-up resistor. “High” – Receiver detection is enabled. “Low” – Receiver detection is disabled.
4	EN	Input	Channel Enable. With internal 300k Ω pull-up resistor. “High” – Channel is in normal operation. “Low” – Channel is in power down mode.
3, 6, 9, 12, 15, 18, Center Pad	GND	GND	Supply Ground
2	NC	NC	No Connect

Power Management

Notebooks, netbooks, and other power sensitive consumer devices require judicious use of power in order to maximize battery life. In order to minimize the power consumption of our devices, Diodes has added an additional adaptive power management feature. When a signal detector is idle for longer than 1.3ms, the corresponding channel will move to low power mode ONLY. (It means both channels will move to low power mode individually).

In the low power mode, the signal detector will still be monitoring the input channel. If a channel is in low power mode and the input signal is detected, the corresponding channel will wake-up immediately. If a channel is in low power mode and the signal detector is idle longer than 6ms, the receiver detection loop will be active again. If load is not detected, then the Channel will move to Device Unplug Mode and monitor the load continuously. If load is detected, it will return to Low Power Mode and receiver detection will be active again per 6ms.

Operating Modes

Mode	R_{IN}	R_{OUT}
PD	67K Ω to GND	HIZ
Unplug Mode	67K Ω to VbiasRx	4K Ω to VbiasTx
Deep Slumber Mode	50 Ω to Vdd	4K Ω to VbiasTx
Slumber Mode	50 Ω to Vdd	4K Ω to Vdd
Active Mode	50 Ω to Vdd	50 Ω to Vdd

Equalization Setting:

EQ is the selection pin for the equalization selection

<i>EQ</i>	Equalizer setting (dB)	
	@2.5GHz	@5GHz
0 (Tie 0Ω to GND)	5.1	10.9
R (Tie Rext to Gnd)	1.9	6.7
F (Leave Open)	3.5	8.9 (Default)
1 (Tie 0Ω to VDD)	6.8	13.1

Flat Gain Setting:

FG is the selection pin for the DC gain

<i>FG</i>	Flat Gain Settings <i>dB</i>
0 (Tie 0Ω to GND)	-3
R (Tie Rext to Gnd)	-1.5
F (Leave Open)	0 (Default)
1 (Tie 0Ω to VDD)	+2

Channel Enable Setting:

EN is the channel enable pin

<i>EN</i>	Channel Enable Setting <i>Setting</i>
0	Disabled
1	Enabled (Default)

Receiver Detection Setting:

RXDET_EN is the receiver detection pin

<i>RXDET_EN</i>	Receiver Detection Setting <i>Setting</i>
0	Disabled
1	Enabled (Default)

Maximum Ratings

(Above which useful life may be impaired. For user guidelines, not tested.)

Storage Temperature.....	-65°C to +150°C
Supply Voltage to Ground Potential.....	-0.5V to +4.6V
DC SIG Voltage.....	-0.5V to V _{DD} +0.5V
Output Current	-25mA to +25mA
Power Dissipation Continuous.....	0.5W
ESD, Human Body Model	-2kV to +2kV

Note:

Stresses greater than those listed under MAXIMUM RATINGS may cause permanent damage to the device. This is a stress rating only and functional operation of the device at these or any other conditions above those indicated in the operational sections of this specification is not implied. Exposure to absolute maximum rating conditions for extended periods may affect reliability.

Control pin Specifications (V_{DD} = 3.3 ± 0.3V TA = 0 to 70°C)

Symbol	Parameter	Min.	Typ.	Max.	Units
2-level control pins					
V _{IH}	DC input logic High	V _{DD} *0.65			V
V _{IL}	DC input logic Low			V _{DD} *0.35	V
I _{IH}	Input High current			25	uA
I _{IL}	Input Low current	-25			uA
4-level control pins					
V _{IH}	DC input logic "High"	0.92*V _{DD}	V _{DD}		V
V _{IF}	DC input logic "Float"	0.59*V _{DD}	0.67*V _{DD}	0.75*V _{DD}	V
V _{IR}	DC input logic "With Rext to GND"	0.25*V _{DD}	0.33*V _{DD}	0.41*V _{DD}	V
V _{IL}	DC input logic "Low"		GND	0.08*V _{DD}	V
I _{IH}	Input High current			50	uA
I _{IL}	Input Low current	-50			uA
Rext	External resistor connects to GND (±5%)	64.6	68	71.4	kΩ

AC/DC Electrical Characteristics (V_{DD} = 3.3 ± 0.3V TA = 0 to 70°C)

Power and Latency						
Symbol	Parameter	Conditions	Min.	Typ.	Max.	Units
V _{dd-3.3}	Supply voltage		3.0	3.3	3.6	V
I _{active}	Active mode current consumption	EN=1 (V _{DD} =3.3V, 10Gbps, compliance test pattern, RXDET_EN=High)		65	88	mA
I _{slumber}	Slumber mode current consumption	EN=1 (V _{DD} =3.3V, no input signal longer than T _{slumber} /RXDET_EN=High)		8	11	mA
I _{DeepSlumber}	Deep slumber mode current consumption	EN=1 (V _{DD} =3.3V, no input signal longer than T _{DeepSlumber} /RXDET_EN=High)		0.4	0.7	
I _{unplug}	Unplug mode current consumption	EN=1, no output load is detected		0.3	0.5	
I _{pd}	Power Down mode current consumption	EN=0		10	50	μA
t _{pd}	Latency	From input to output			2	ns

AC/DC Electrical Characteristics Cont.

Symbol	Parameter	Conditions	Min.	Typ.	Max.	Units
CML Receiver Input (100Ω differential)						
Receiver Electrical Specification						
$C_{RXparasitic}$	The parasitic capacitor for RX				1.0	pF
$R_{RX-DIFF-DC}$	DC Differential Input Impedance		72		120	Ω
$R_{RX-SINGLE-DC}$	DC single ended input impedance	DC impedance limits are need to guarantee RxDet. Measured with respect to GND over a voltage of 500mV max	18		30	
$Z_{RX-HIZ-DC-PD}$	DC input CM input impedance for $V > 0$ during reset or power down	($V_{cm}=0$ to 500mV)	25			kΩ
$C_{ac_coupling}$	AC coupling capacitance		75		265	nF
$V_{RX-CM-AC-P}$	Common mode peak voltage	AC up to 5GHz			150	mV-peak
$V_{RX-CM-DC-Active-Idle-Delta-P}$	Common mode peak voltage $ Avg_{u0}(V_{TX-D+} + V_{TX-D-})/2 - Avg_{u1}(V_{TX-D+} + V_{TX-D-})/2 $	Between U0 and U1. AC up to 5GHz			200	mV-peak
Transmitter Electrical Specification						
$V_{TX-DIFF-PP}$	Ouput differential p-p voltage swing	Differential Swing $ V_{TX-D+} - V_{TX-D-} $			1.2	Vppd
$R_{TX-DIFF-DC}$	DC Differential TX Impedance		72		120	Ω
$V_{TX-RCV-DET}$	The amount of voltage change allowed during RxDet				600	mV
$C_{ac_coupling}$	AC coupling capacitance		75		265	nF
$T_{TX-EYE(10Gbps)}$	Transmitter eye, Include all jittter	At the silicon pad. 10Gbps	0.646			UI
$T_{TX-EYE(5Gbps)}$	Transmitter eye, Include all jittter	At the silicon pad. 5Gbps	0.625			UI
$T_{TX-DJ-DD(10Gbps)}$	Transmitter deterministic jittter	At the silicon pad. 10Gbps			0.17	UI
$T_{TX-DJ-DD(5Gbps)}$	Transmitter deterministic jittter	At the silicon pad. 5Gbps			0.205	UI
$C_{txparasitic}$	The parasitic capacitor for TX				1.1	pF
$R_{TX-DC-CM}$	Common mode DC output Impedance		18		30	Ω
$V_{TX-DC-CM}$	The instantaneous allowed DC common mode voltage at the connector side of the AC coupling capacitors	$ V_{TX-D+} + V_{TX-D-} /2$	0		2.2	V
V_{TX-C}	Common-Mode Voltage	$ V_{TX-D+} + V_{TX-D-} /2$	VDD-1.5V		VDD	V
$V_{TX-CM-AC-PP-Active}$	Active mode TX AC common mode voltage	$V_{TX-D+} + V_{TX-D-}$ for both time and amplitude			100	mVpp

AC/DC Electrical Characteristics Cont.

Symbol	Parameter	Conditions	Min.	Typ.	Max.	Units
$V_{TX-CM-DC}$ Active_Idle-Delta	Common mode delta voltage $ Avg_{u0}(V_{TEX-D+} + V_{TX-D-})/2 - Avg_{u1}(V_{TX-D+} + V_{TX-D-})/2 $	Between U0 to U1			200	mV-peak
$V_{TX-Idle-Diff-AC-pp}$	Idle mode AC common mode delta voltage $ V_{TX-D+} - V_{TX-D-} $	Between Tx+ and Tx- in idle mode. Use the HPF to remove DC components. =1/LPF. No AC and DC signals are applied to Rx terminals .			10	mVppd
$V_{TX-Idle-Diff-DC}$	Idle mode DC common mode delta voltage $ V_{TX-D+} - V_{TX-D-} $	Between Tx+ and Tx- in idle mode. Use the LPF to remove DC components. =1/HPF. No AC and DC signals are applied to Rx terminals.			10	mV
Channel Performance						
G_p	Peaking gain (Compensation at 5GHz, relative to 100MHz, 100mV _{p-p} sine wave input, FG=F)	EQ=0		10.9		dB
		EQ=R		6.7		
		EQ=F		8.9		
		EQ=1		13.1		
		Variation around typical	-3		+3	dB
G_F	Flat gain (100MHz, EQ=F)	FG=0		-3		dB
		FG=R		-1.5		
		FG=F		0		
		FG=1		+2		
		Variation around typical	-3		+3	dB
V_{SW_100M}	-1dB compression point output swing (at 100MHz)			1000		mVppd
V_{SW_5G}	-1dB compression point output swing (at 5GHz)			750		mVppd
$V_{noise-input}$	Input-referred noise	100MHz to 5GHz, FG=1, EQ=R, Figure 2		0.6		mV _{RMS}
		100MHz to 5GHz, FG=1, EQ=1, Figure 2		0.5		
$V_{noise-output}$	Output-referred noise ¹	100MHz to 5GHz, FG=1, EQ=R, Figure 2		0.8		mV _{RMS}
		100MHz to 5GHz, FG=1, EQ=1, Figure 2		1		
Signal and Frequency Detectors						
V_{th_upm}	Unplug mode detector threshold	Threshold of LFPS when the input impedance of the redriver is 67kohm to Vbi-asRx only. Used in the unplug mode.	200		800	mVppd
V_{th_dsm}	Deep slumber mode detector threshold	LFPS signal threshold in Deep slumber mode	100		600	mVppd
V_{th_am}	Active mode detector threshold	Signal threshold in Active and slumber mode	45		175	mVppd
F_{th}	LFPS frequency detector	Detect the frequency of the input CLK pattern	100		400	MHz

Note: 1. Guaranteed by design and characterization.

PI3EQX1001

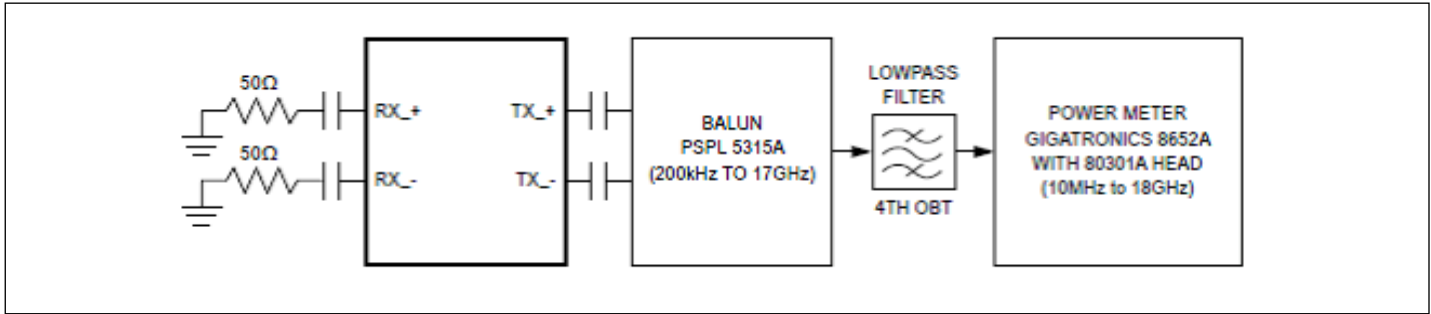

Figure2. Noise test configuration

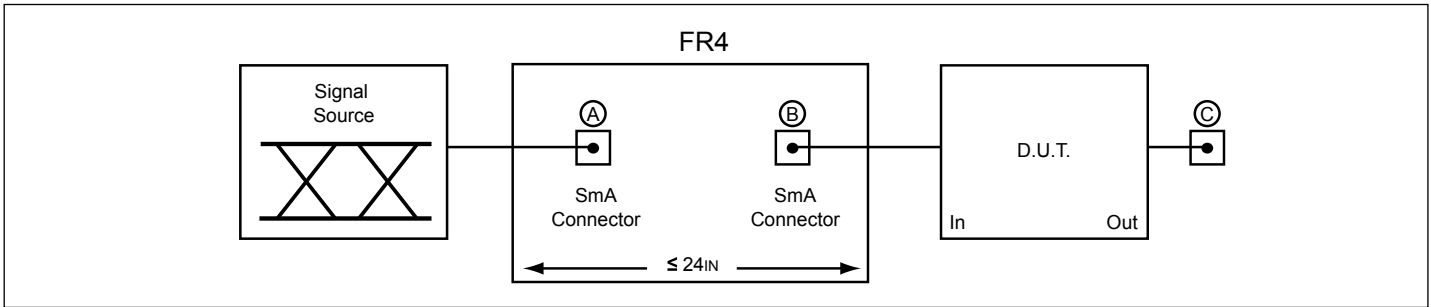

Figure3. Test Condition Referenced in the Electrical Characteristic Table

PI3EQX1001

Packaging Mechanical: 18-pin X2QFN

SYMBOLS	MIN.	NOM.	MAX.
A	0.30	0.35	0.40
A1	0.00	0.02	0.05
A3	0.127 REF.		
b	0.15	0.20	0.25
D	1.95	2.00	2.05
E	1.95	2.00	2.05
e	0.40 BSC		
L	0.15	0.25	0.35
D2	0.95	1.00	1.05
E2	0.95	1.00	1.05

NOTE :
 1. ALL DIMENSIONS ARE IN mm. ANGLES IN DEGREES.
 2. REFER JEDEC MO-288
 3. RECOMMENDED LAND PATTERN IS FOR REFERENCE ONLY. MESH STENCIL DESIGN IS RECOMMENDED.

		DATE: 03/31/14
DESCRIPTION: 18-Pin, X2QFN 2X2mm		
PACKAGE CODE: XUA (XUA18)		
DOCUMENT CONTROL #: PD-2184		REVISION: -

14-0039

For latest package info.

please check: <http://www.diodes.com/design/support/packaging/pericom-packaging/packaging-mechanicals-and-thermal-characteristics/>

Ordering Information

Ordering Number	Package Code	Package Description
PI3EQX1001XUAEX	XUA	18-Pin, 2X2mm (X2QFN)

Notes:

- Thermal characteristics can be found on the company web site at www.diodes.com/design/support/packaging/
- E = Pb-free and Green
- X suffix = Tape/Reel

IMPORTANT NOTICE

DIODES INCORPORATED MAKES NO WARRANTY OF ANY KIND, EXPRESS OR IMPLIED, WITH REGARDS TO THIS DOCUMENT, INCLUDING, BUT NOT LIMITED TO, THE IMPLIED WARRANTIES OF MERCHANTABILITY AND FITNESS FOR A PARTICULAR PURPOSE (AND THEIR EQUIVALENTS UNDER THE LAWS OF ANY JURISDICTION).

Diodes Incorporated and its subsidiaries reserve the right to make modifications, enhancements, improvements, corrections or other changes without further notice to this document and any product described herein. Diodes Incorporated does not assume any liability arising out of the application or use of this document or any product described herein; neither does Diodes Incorporated convey any license under its patent or trademark rights, nor the rights of others. Any Customer or user of this document or products described herein in such applications shall assume all risks of such use and will agree to hold Diodes Incorporated and all the companies whose products are represented on Diodes Incorporated website, harmless against all damages.

Diodes Incorporated does not warrant or accept any liability whatsoever in respect of any products purchased through unauthorized sales channel.

Should Customers purchase or use Diodes Incorporated products for any unintended or unauthorized application, Customers shall indemnify and hold Diodes Incorporated and its representatives harmless against all claims, damages, expenses, and attorney fees arising out of, directly or indirectly, any claim of personal injury or death associated with such unintended or unauthorized application.

Products described herein may be covered by one or more United States, international or foreign patents pending. Product names and markings noted herein may also be covered by one or more United States, international or foreign trademarks.

This document is written in English but may be translated into multiple languages for reference. Only the English version of this document is the final and definitive format released by Diodes Incorporated.

LIFE SUPPORT

Diodes Incorporated products are specifically not authorized for use as critical components in life support devices or systems without the express written approval of the Chief Executive Officer of Diodes Incorporated. As used herein:

A. Life support devices or systems are devices or systems which:

1. are intended to implant into the body, or

2. support or sustain life and whose failure to perform when properly used in accordance with instructions for use provided in the labeling can be reasonably expected to result in significant injury to the user.

B. A critical component is any component in a life support device or system whose failure to perform can be reasonably expected to cause the failure of the life support device or to affect its safety or effectiveness.

Customers represent that they have all necessary expertise in the safety and regulatory ramifications of their life support devices or systems, and acknowledge and agree that they are solely responsible for all legal, regulatory and safety-related requirements concerning their products and any use of Diodes Incorporated products in such safety-critical, life support devices or systems, notwithstanding any devices- or systems-related information or support that may be provided by Diodes Incorporated. Further, Customers must fully indemnify Diodes Incorporated and its representatives against any damages arising out of the use of Diodes Incorporated products in such safety-critical, life support devices or systems.

Copyright © 2016, Diodes Incorporated

www.diodes.com