

THIS DRAWING IS UNPUBLISHED. RELEASED FOR PUBLICATION  
 © COPYRIGHT - By - ALL RIGHTS RESERVED.

LOC	DIST	REVISIONS			
P	LTR	DESCRIPTION	DATE	DWN	APVD
AF	50	E	REVISED PER ECR-12-013518	23NOV2012	KH PD

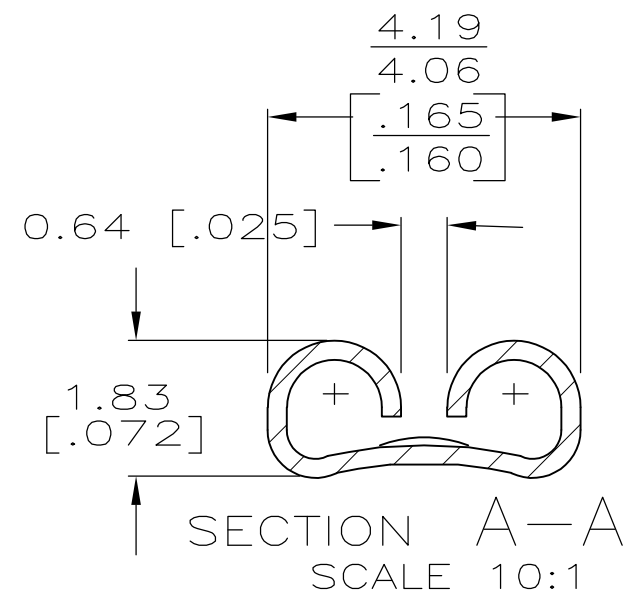

- CONTINUOUS STRIP ON REELS
  - WIRE SIZE IS #22-#18 AWG
  - INSULATION RANGE IS 2.29-2.79 [.090-.110] DIA.
  - MATING TAB THK IS 0.51±0.025 [.020±.001].
- ⚠ PRELIMINARY - NOT FOR PRODUCTION

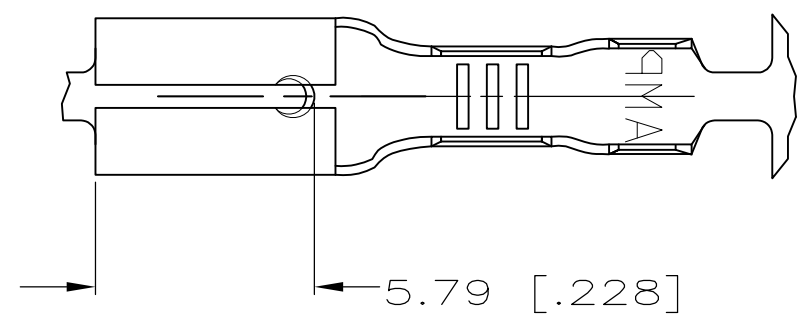
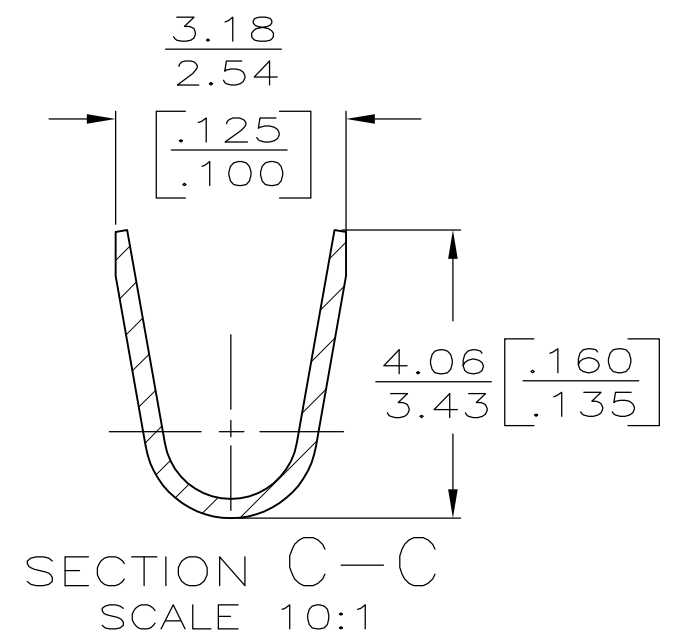
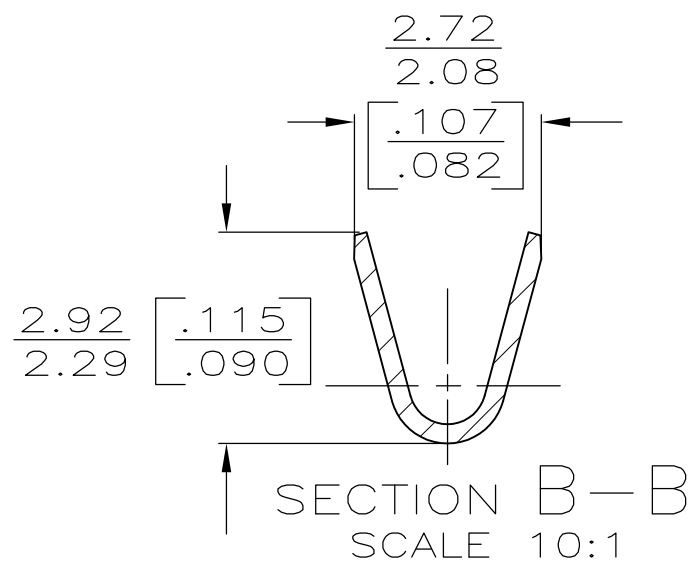
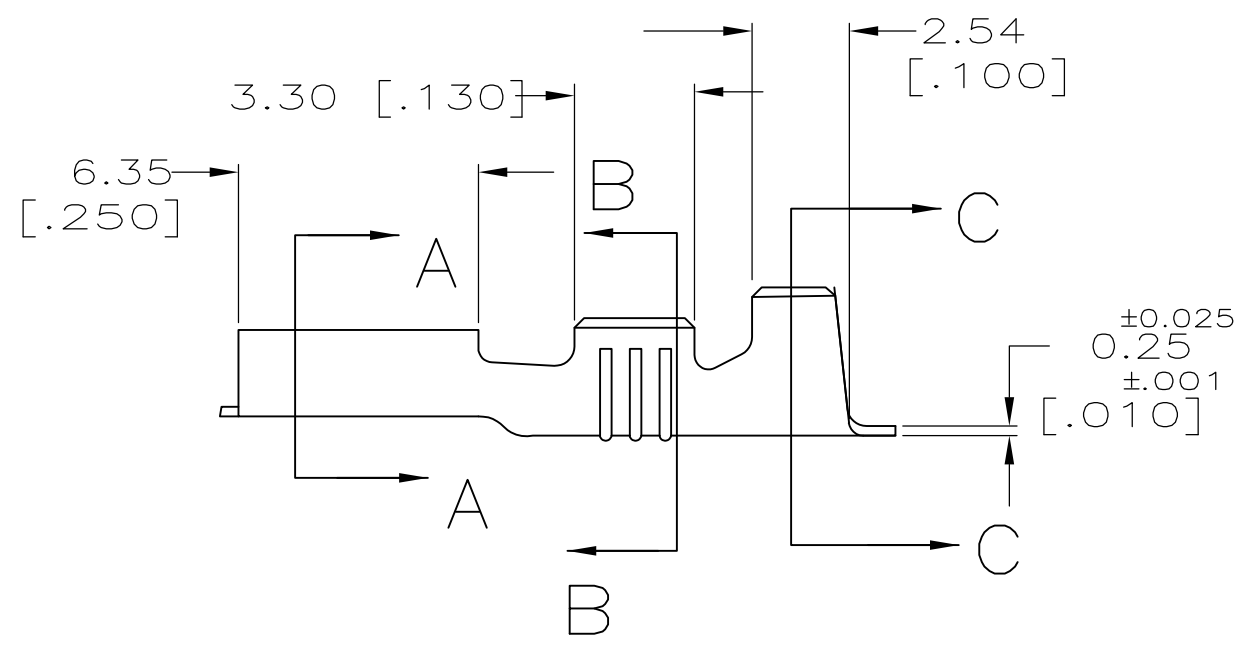

H04 PHOS BRONZE	⚠ 63705-3
BRASS	⚠ 63705-2
BRASS	63705-1
MATERIAL	PART NO.

THIS DRAWING IS A CONTROLLED DOCUMENT.		DWN	JR RUTH	3/31/93	<b>STE</b> TE Connectivity		
DIMENSIONS: mm [INCHES]		CHK	MS FEHER	3/31/93			
TOLERANCES UNLESS OTHERWISE SPECIFIED:		APVD	J GILLISPIE	3/31/93	NAME		
0 PLC ± -		PRODUCT SPEC		RECEPTACLE, FASTON, 3.18 [.125] SERIES			
1 PLC ± -		APPLICATION SPEC		SIZE	CAGE CODE	DRAWING NO	RESTRICTED TO
2 PLC ± 0.25 [.010]		MATERIAL		A3 00779 C-63705			-
3 PLC ± -		FINISH		CUSTOMER DRAWING			SCALE 5:1
4 PLC ± -		SEE TABLE		SCALE 5:1			SHEET 1 OF 1
ANGLES ± -		-		SCALE 5:1			REV E