

Evaluating the **ADPD4000/ADPD4001** Multimodal Front End

FEATURES

- Board supports **ADPD4000** and **ADPD4001** population
- ADPD4000** (SPI) is the default board population
- All inputs and outputs are accessible to the user
- 3 separately driven green LEDs included
- 1 red and 1 IR LED included
- Metal baffle to block optical crosstalk
- Works with the **Wavetool Evaluation Software** allowing
 - Time domain graphing and logging
 - Frequency domain graphing
 - Statistical analysis
 - Data streaming to other applications

EVALUATION KIT CONTENTS

- EVAL-ADPD4000Z-PPG evaluation board
- Ribbon cable
- Wrist strap, with hook and loop fastener

ADDITIONAL EQUIPMENT NEEDED

- PC running Windows® 7 or Windows 10 operating system
- EVAL-ADPDUZ**, Cortex-M4 microcontroller motherboard
- Optional: **EVAL-ADPDM3Z**, alternative Cortex-M3 microcontroller motherboard (available from the **EVAL-ADPD2140Z** product page)

ONLINE RESOURCES

- ADPD4000/ADPD4001** data sheet
- Wavetool Evaluation Software** package

GENERAL DESCRIPTION

The EVAL-ADPD4000Z-PPG evaluation board provides users with a simple means of evaluating the **ADPD4000/ADPD4001** photometric front end.

The EVAL-ADPD4000Z-PPG evaluation board implements a simple discrete optical design for vital signs monitoring applications, specifically wrist-based photoplethysmography (PPG).

The EVAL-ADPD4000Z-PPG has three green light emitting diodes (LEDs), one infrared (IR), and one red LED, all separately driven. A single 7 mm² photodiode (PD) is populated on the board. The PD has no optical filter coating. However, a pin for pin alternative device with an IR block filter is available.

The full evaluation system includes the **Wavetool Evaluation Software** graphical user interface (GUI) that provides users with low level register access and high level system configurability. Raw data streamed to this tool can be displayed in real time with limited latency. Views are provided for both frequency and time domain analysis.

A user datagram protocol (UDP) transfer capability from the **Wavetool Evaluation Software** (available for download on the **EVAL-ADPD4000Z-PPG** product page) allows data stream connections and register configurability to external analysis programs, such as LabVIEW® or MATLAB®, in real time.

The EVAL-ADPD4000Z-PPG board is powered by the **EVAL-ADPDUZ** microcontroller board (obtained from the **EVAL-ADPD4000Z-PPG** product page). In addition to the power requirements, serial port interface (SPI) (default) or I²C data streams are received from the **ADPD4000** by the microcontroller. A ribbon cable connects the two boards. The microcontroller repackages the data, sending it to a virtual serial port over the USB to the PC, displayed on the **Wavetool Evaluation Software**. The EVAL-ADPD4000Z-PPG can also be connected directly to the microcontroller development system of the user, using the SPI for the **ADPD4000** (or I²C for the **ADPD4001**).

The **ADPD4000/ADPD4001** data sheet, available at www.analog.com, provides full specifications for the **ADPD4000/ADPD4001**. Consult the **ADPD4000/ADPD4001** data sheet in conjunction with this user guide when using the EVAL-ADPD4000Z-PPG.

TABLE OF CONTENTS

Features	1	Connecting the EVAL-ADPDUCZ to the EVAL-ADPD4000Z-PPG Board	4
Evaluation Kit Contents.....	1	Starting the Wavetool Evaluation Software	5
Additional Equipment Needed	1	USB UART Connection.....	5
Online Resources	1	Select the Proper View.....	5
General Description	1	Loading the Device Configuration	6
Revision History	2	Starting Real-Time Graphing	7
Evaluation Board Photographs	3	Optimizing and Running the ADPD4000 and ADPD4001	7
Getting Started	4	Evaluation Board Schematics and Artwork.....	8
Install the Wavetool Evaluation Software.....	4		

REVISION HISTORY

6/2019—Revision 0: Initial Version

EVALUATION BOARD PHOTOGRAPHS

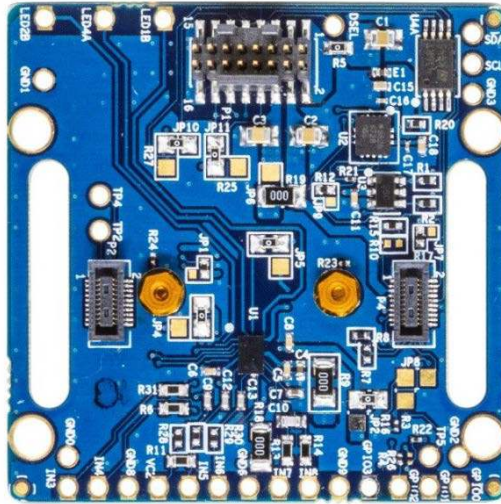

20180-001

Figure 1. EVAL-ADPD4000Z-PPG Top Side

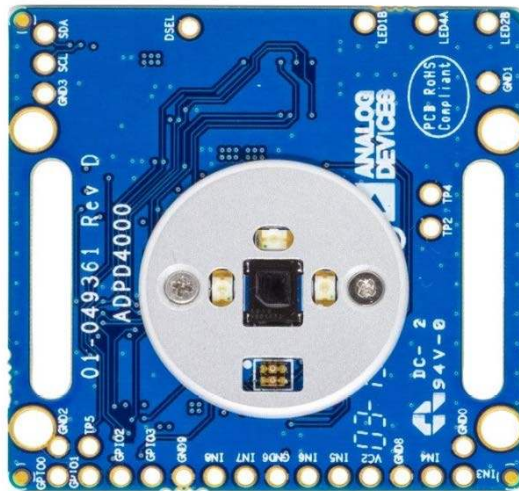

20180-002

Figure 2. EVAL-ADPD4000Z-PPG Bottom Side, Optical

GETTING STARTED

INSTALL THE WAVETOOL EVALUATION SOFTWARE

Download the [Wavetool Evaluation Software](#) package from the [EVAL-ADPD4000Z-PPG](#) product page.

Version 2.1.x or later of the [Wavetool Evaluation Software](#) is required to work with this evaluation board. It is recommended to download the latest version from the [Wavetool Evaluation Software](#) link.

Unzip the downloaded folder, if required, and run the [Wavetool Evaluation Software](#) executable file. Some users have found that they must install the tool as the administrative user or run Windows in elevated mode to ensure drivers are properly downloaded during the installation.

Follow the prompts, beginning with the setup window shown in Figure 3 for software installation.

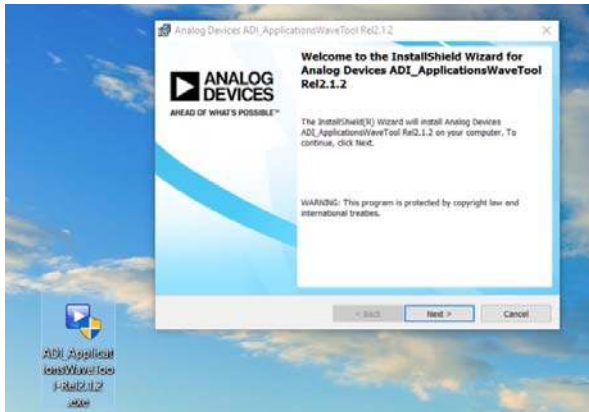

Figure 3. *Wavetool Evaluation Software, Installer Window*

A click through licensing window appears during installation of the [Wavetool Evaluation Software](#) package. The terms of the license must be read and accepted to install the package.

If the default directory was selected in the installation, for example, `C:\Analog Devices\ADI_ApplicationsWaveTool-Rel2.1.5`, the executable file is then found in the top level directory (note that the version number may be different) and named **Applications Wavetool.exe**. Run this file directly, or create and place a shortcut on the desktop.

Note that there is a full help utility included in the [Wavetool Evaluation Software](#), as well as links to videos and other documentation in the [Wavetool Evaluation Software](#) library showing how to use the tool (see Figure 4).

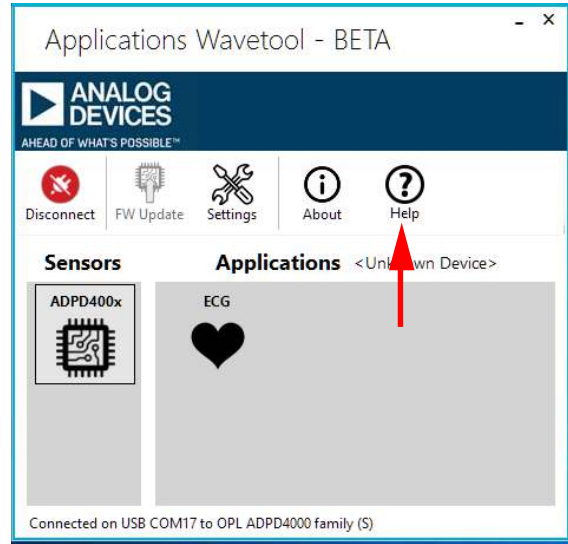

Figure 4. *Wavetool Evaluation Software, Getting Help*

CONNECTING THE EVAL-ADPUCZ TO THE EVAL-ADPD4000Z-PPG BOARD

Connect the keyed gray ribbon cable between the EVAL-ADPD4000Z-PPG board and the [EVAL-ADPUCZ](#) Cortex-M4 micro-controller motherboard.

Connect the USB cable between the [EVAL-ADPUCZ](#) evaluation motherboard and the PC. Use the USB miniconnector on the short side of the board as shown in Figure 5. After connection, turn the white slider power switch to the on position (see Figure 5). If the switch is already on, toggle the power switch to off, wait 3 sec, then toggle the switch back on again.

When the USB cable is connected from the [EVAL-ADPUCZ](#) back to the PC, the second LED below the power switch illuminates, indicating that the on-board battery is being charged from the PC. When the power switch is turned to the on position, the LED immediately below the power switch illuminates, indicating that the [EVAL-ADPUCZ](#) Cortex-M4 microcontroller is also on.

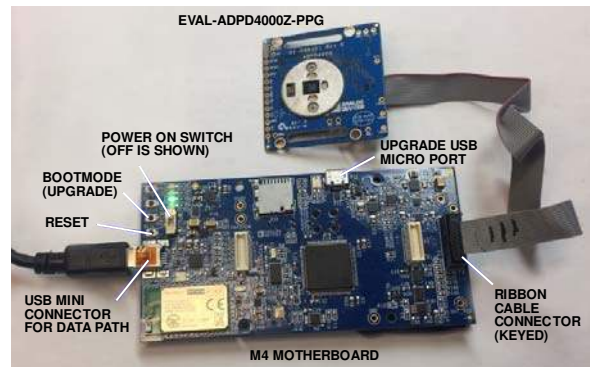

Figure 5. *Connect the EVAL-ADPUCZ to the EVAL-ADPD4000Z-PPG*

The USB microconnector on the long side of the board is only used for firmware upgrades for the EVAL-ADPDUZC board.

Figure 6 shows the stretch wrist strap that is shipped with the EVAL-ADPD4000Z-PPG board.

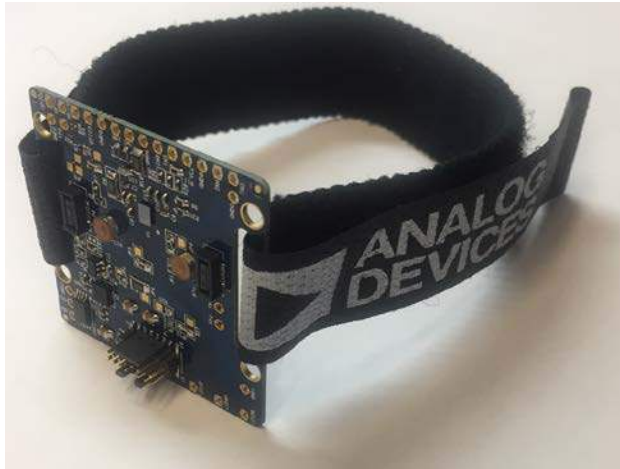

Figure 6. Optional Wrist Strap on EVAL-ADPD4000Z-PPG

Figure 7 shows the connectivity of the EVAL-ADPD4000Z-PPG board to the EVAL-ADPDM3Z Cortex-M3 microcontroller motherboard. The EVAL-ADPDM3Z is an alternative microcontroller typically used for demonstration purposes in smaller form factor situations.

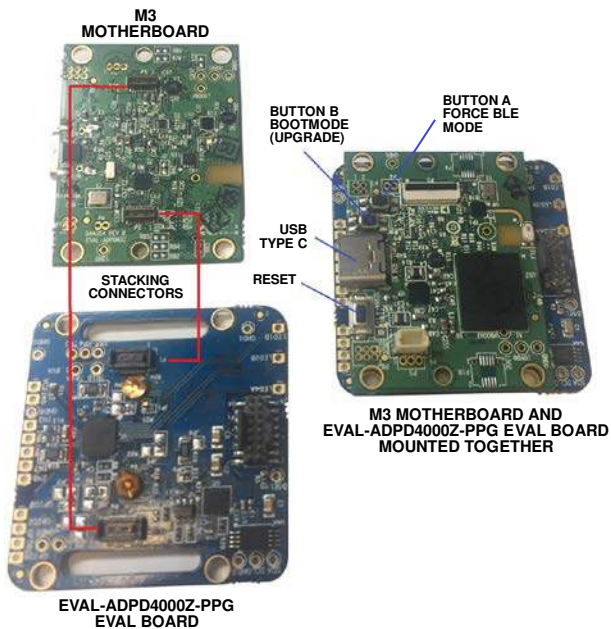

Figure 7. Connecting the EVAL-ADPDM3Z to the EVAL-ADPD4000Z-PPG

STARTING THE WAVETOOL EVALUATION SOFTWARE

After the [Wavetool Evaluation Software](#) is installed and the EVAL-ADPDUZC Cortex-M4 microcontroller motherboard and the EVAL-ADPD4000Z-PPG board are connected to the PC, the user can start the [Wavetool Evaluation Software](#).

The executable file is **Applications Wavetool.exe** found in the appropriate installation directory as described in the [Install the Wavetool Evaluation Software](#) section.

USB UART CONNECTION

To establish the software connection between the [Wavetool Evaluation Software](#) and the evaluation board firmware, select a connection to the specific UART port used by the EVAL-ADPDUZC Cortex-M4 microcontroller.

Click the green circular **Connect** icon (see Figure 8) and choose the specific COM port from the list.

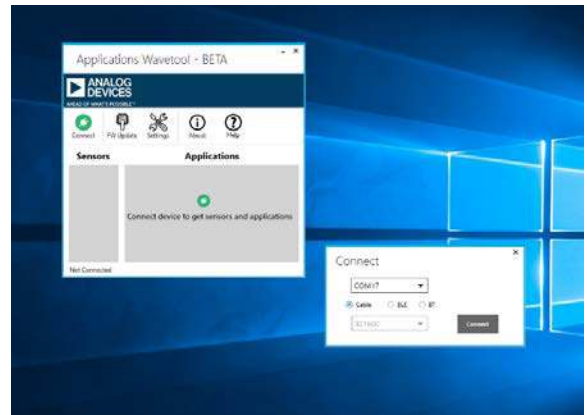

Figure 8. Connect to the PC COMx Port

For this example, the PC running the [Wavetool Evaluation Software](#) is connected via the USB cable to the evaluation setup. Select the proper COM port found in the dropdown list to connect the [Wavetool Evaluation Software](#) to the device.

If connection via Bluetooth® or Bluetooth low energy (BLE) is required, or if there are any other connection issues, refer to the [Wavetool Evaluation Software](#) user guide that is provided via the **Help** icon from within the software package (see Figure 4).

SELECT THE PROPER VIEW

After the COM port connection is established, an EEPROM on the evaluation board is read so that the [Wavetool Evaluation Software](#) can determine what type of evaluation board it is communicating to. Look at the bottom line of the window in Figure 9.

The text states: **Connected on USB COM17 to OPL ADPD4000 family (S)**. The **(S)** indicates SPI connection, whereas the **(I)** indicates an I²C connection.

For a specific evaluation board, various application modes and sensor devices are displayed (see Figure 9).



Figure 9. Select Sensor to Open **ADPD Device** Window

In the **Sensors** section, select the **ADPD400x** sensor to open the window shown in Figure 10 for the EVAL-ADPD400Z-PPG. If ECG leads are connected to this evaluation board, select the ECG application within the **Applications** section, which is a specific mode of operation for the EVAL-ADPD400Z-PPG.

If more information is required about any of the demonstration applications, refer to the [Wavetool Evaluation Software](#) user guide provided via the **Help** icon from within the software package.

LOADING THE DEVICE CONFIGURATION

In the upper left corner of the **ADPD Device** window, click the gear icon (see the red box in Figure 10) to open the **ADPD Config** window (see Figure 10 insert).

Load the device configuration file for the **ADPD4000** or **ADPD4001** device. The [Wavetool Evaluation Software](#) provides specific device configurations that may be suitable for the experimental requirements of a user. These device configuration files are ***.dcfg** extension files.

Select the file from one of two file folder icons in the upper left of the **ADPD Config** window. The first folder (see the blue box in Figure 10) shows local copies of the device configuration file. The folder in the green box shows consistently updated files found remotely in the cloud.

For this example of PPG measurements, select the configuration file that can be found in both the remote and local folders.

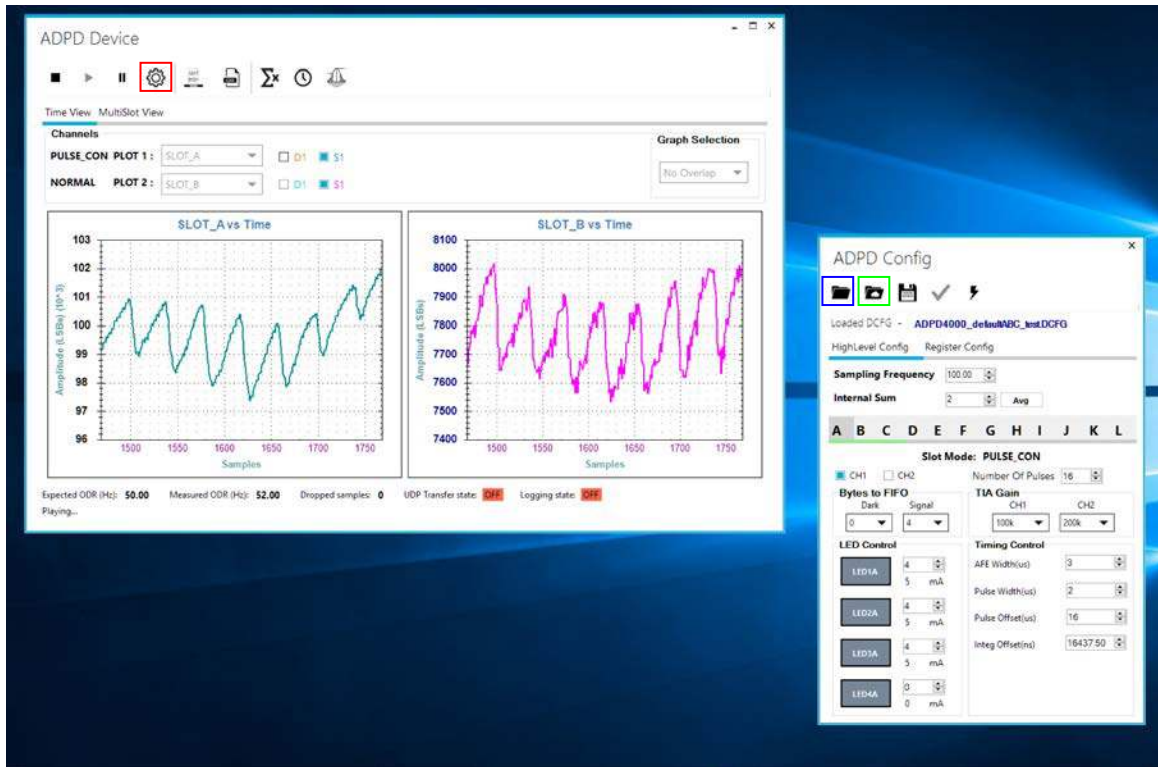

Figure 10. Connect to the PC COMx Port

STARTING REAL-TIME GRAPHING

When the [ADPD4000](#) or [ADPD4001](#) device is configured, data can be read from the EVAL-ADPD4000Z-PPG. The [ADPD4000](#) and [ADPD4001](#) allow data to be collected in sequential, time division multiplex (TDM). To observe the data, select the appropriately configured time slot.

In this example, the configuration loaded is [ADPD4000_defaultABC_test.dcfg](#) and configures three separate time slots. **SLOT_A** uses the three green LEDs, **SLOT_B** uses the red LED, and **SLOT_C** uses the IR LED. All the slots are configured to run and use the same photodiode input.

Select two of the time slots to display from the slot selection dropdown menus in the **ADPD Device** window. Figure 10 shows the data for **SLOT_A** and **SLOT_B**. After selecting the appropriate slots, click the play button (the small triangular black icon) in the menu bar in the upper left side of the **ADPD Device** window.

Clicking play causes data from the selected slots to be streamed to the PC and displayed. The red and green LEDs on the EVAL-ADPD4000Z-PPG are now lit (the IR LED is also lit, but cannot be seen).

Shown in the graphs of Figure 10 is an example of a PPG signal measured from a finger pressed lightly to the metal disk surface covering the photodiode and the LEDs. Note that a wait of several seconds may be needed for the waveform to stabilize while maintaining a light but consistent finger contact.

It is possible, using the [Wavetool Evaluation Software](#), to save the raw data to a comma separated values (.csv) file that can be read easily into Excel®. Explore the icons in the **ADPD Device** window. Pop up tool tips text provide explanations of icon functions

OPTIMIZING AND RUNNING THE [ADPD4000](#) AND [ADPD4001](#)

After the configuration file is loaded, the settings can be further optimized using the **ADPD Config** window shown in the insert in Figure 10. Typically, the device is set up under conditions, for example, measuring the response from a fixed reflector or measuring a PPG signal from the wrist or finger.

Settings can be optimized for any set of conditions by manipulating LED drive currents, transimpedance amplifier (TIA) gain, and analog front-end (AFE) timing, or by using different operating modes that may be more optimal for a specific set of measurements, for example, using float mode for very low current transfer ratio (CTR).

For information on optimization of the [ADPD4000](#) and [ADPD4001](#), refer to the [ADPD4000/ADPD4001](#) data sheet.

For functional descriptions of the [Wavetool Evaluation Software](#), and some of the application demonstration modes, refer to the [Wavetool Evaluation Software](#) itself. The wavetool provides links to videos and additional software documentation within its help utility (see Figure 4).

EVALUATION BOARD SCHEMATICS AND ARTWORK

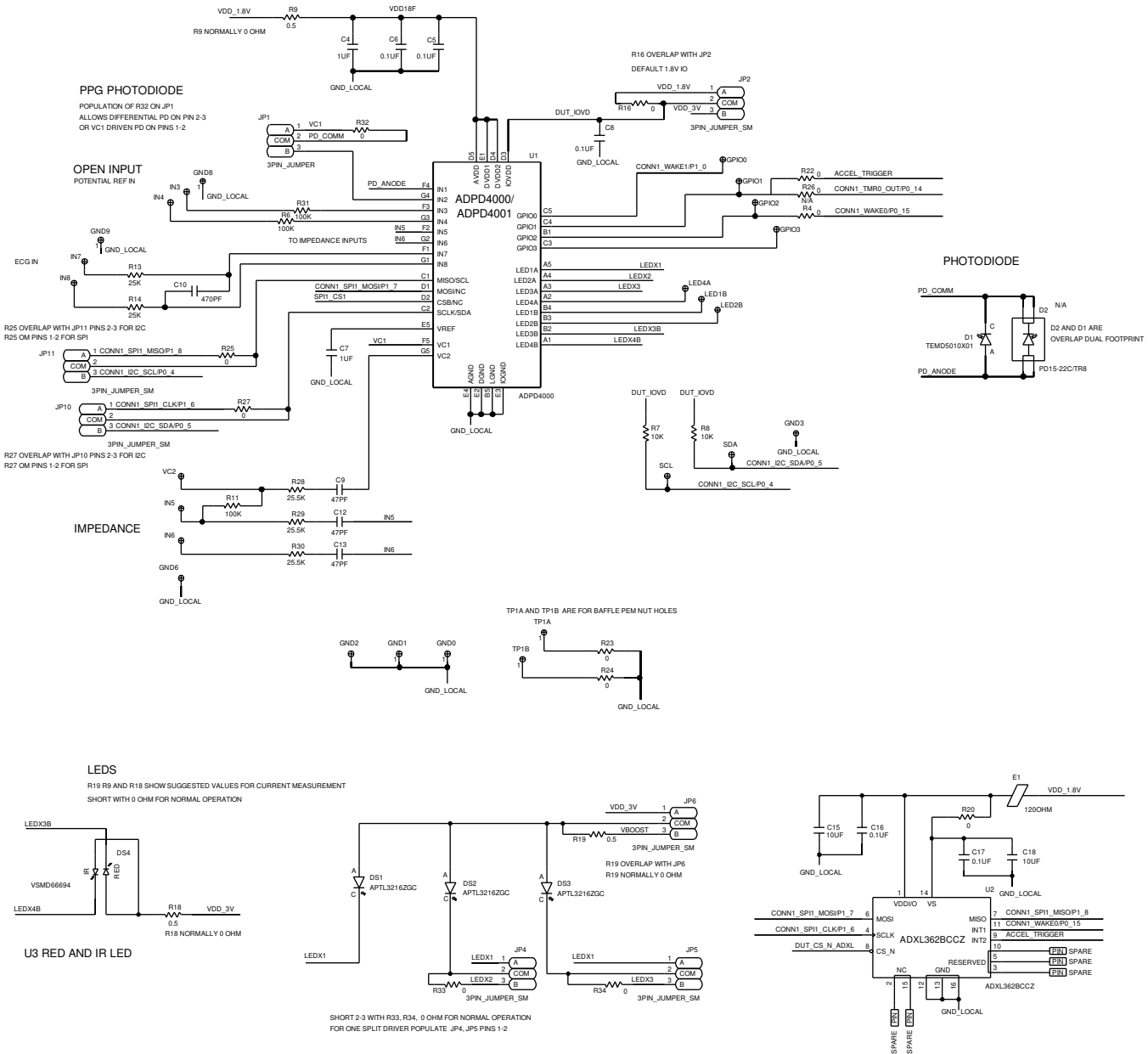
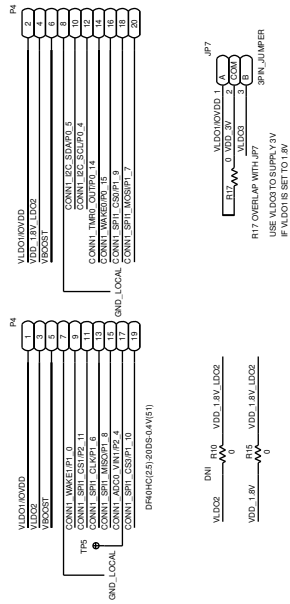

Figure 11. EVAL-ADPD400Z-PPG Schematic, Page 1

20180-01

STACKING CONNECTOR TO M3 "WATCH" STYLE MOTHERBOARD CONNECTOR 1: 1.8V INTERFACE CONNECTOR 1



PIN HEADER FOR RIBBON CABLE CONNECTION TO M4 MOTHERBOARD 1.8V INTERFACE

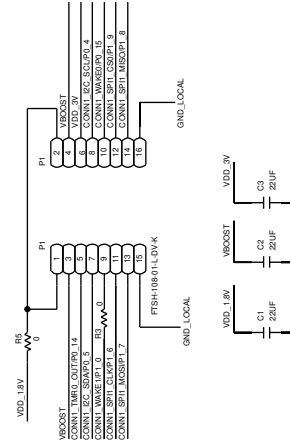

EXTRA POWER BYPASS CAPS FOR RIBBON CABLE

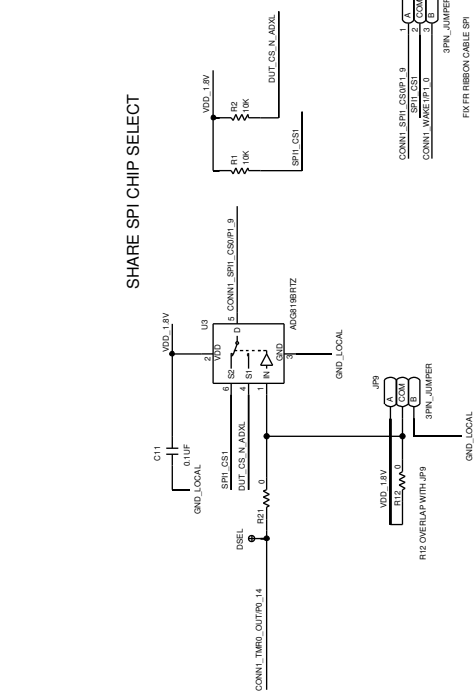

SHARE SPI CHIP SELECT

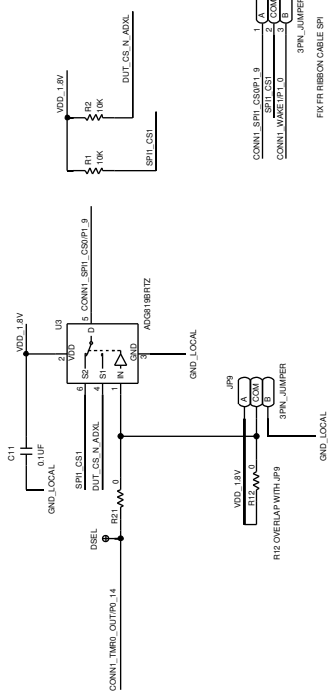

Figure 12. EVAL-ADPD400Z-PPG Schematic, Page 2

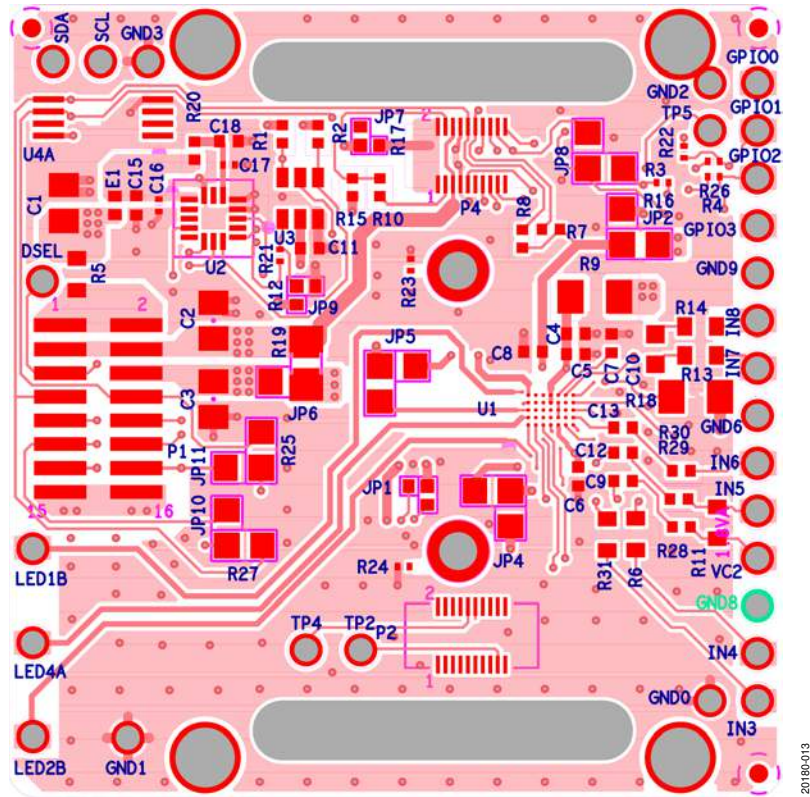

Figure 13. Component: Top Layer and Silkscreen

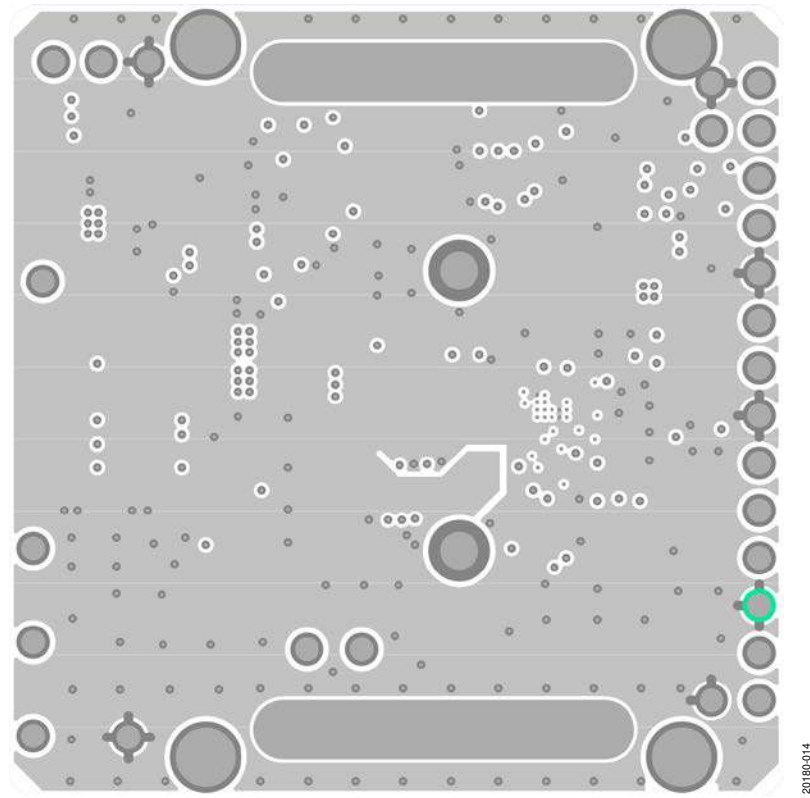

Figure 14. Layer 2, Ground

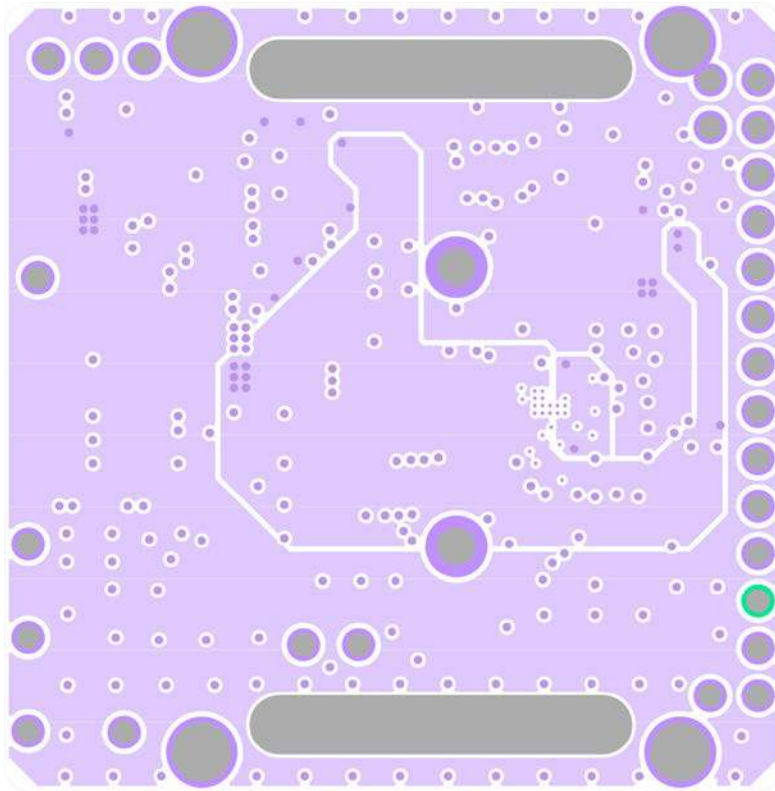

Figure 15. Layer 3, Power

20180-015

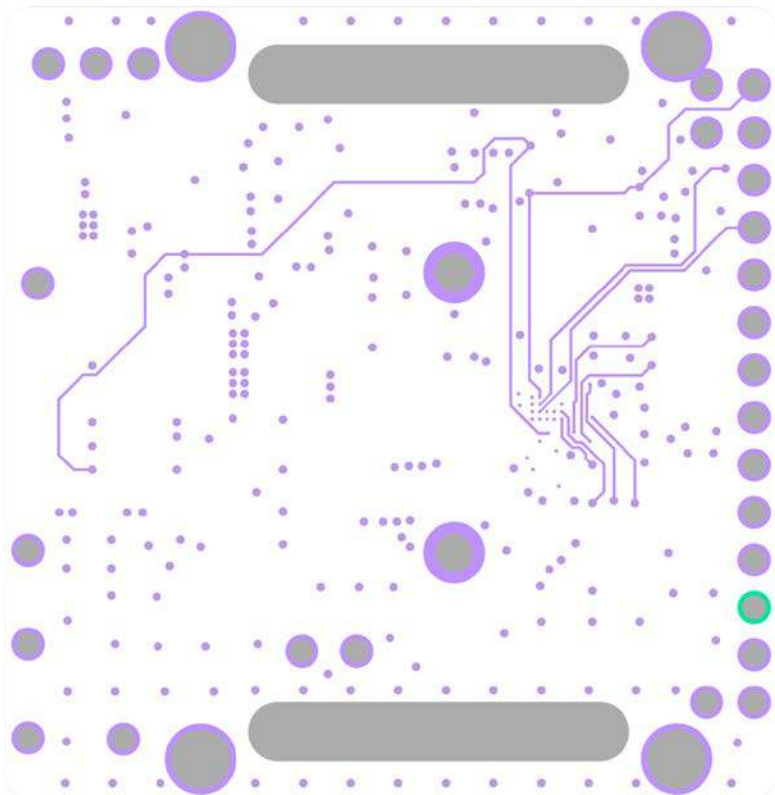
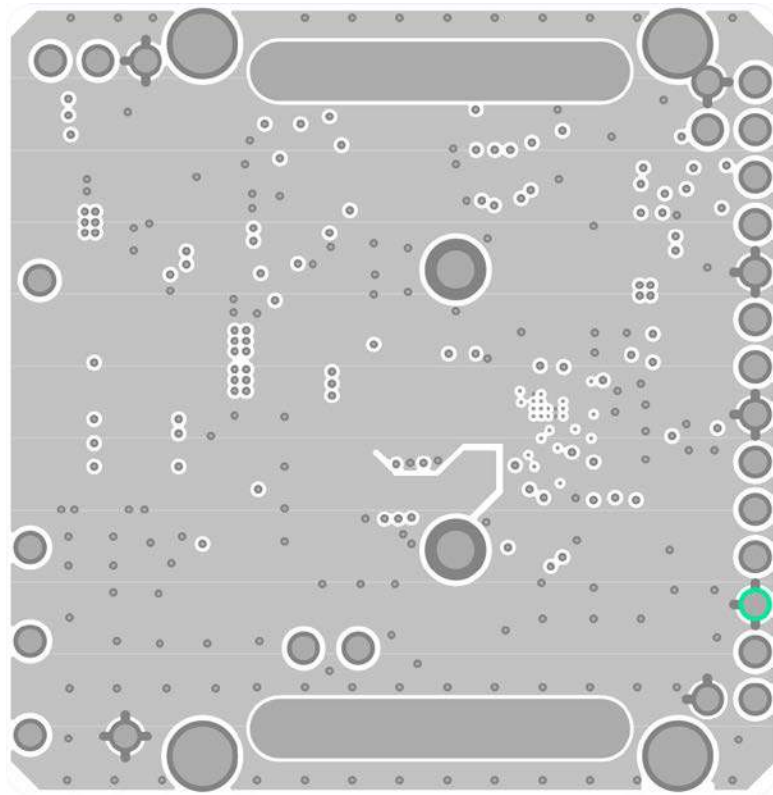

Figure 16. Layer 4, Inner Signal

20180-016



20180-017

Figure 17. Layer 5, Ground

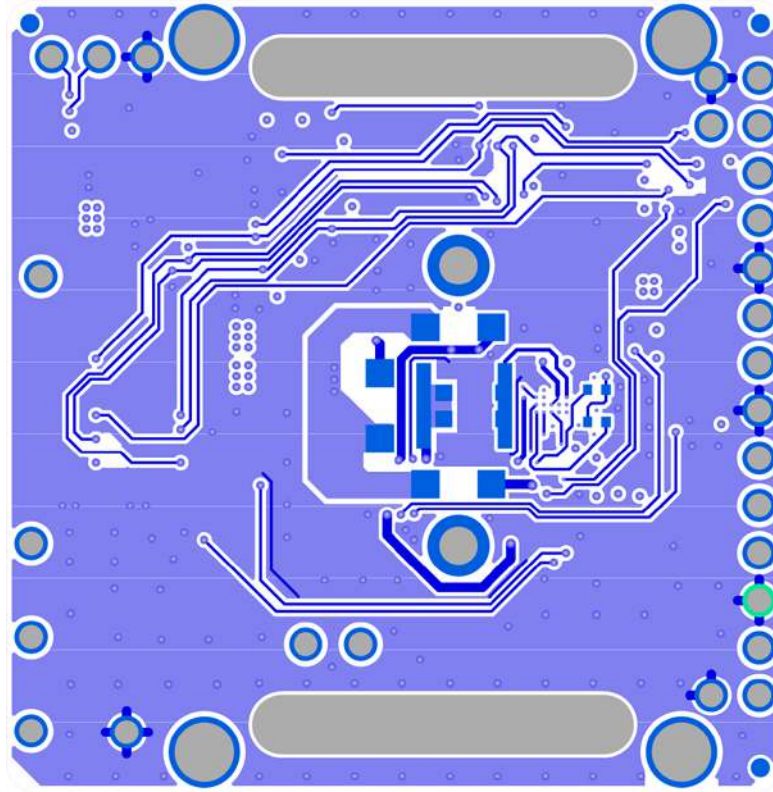

20180-018

Figure 18. Bottom Layer, Optical

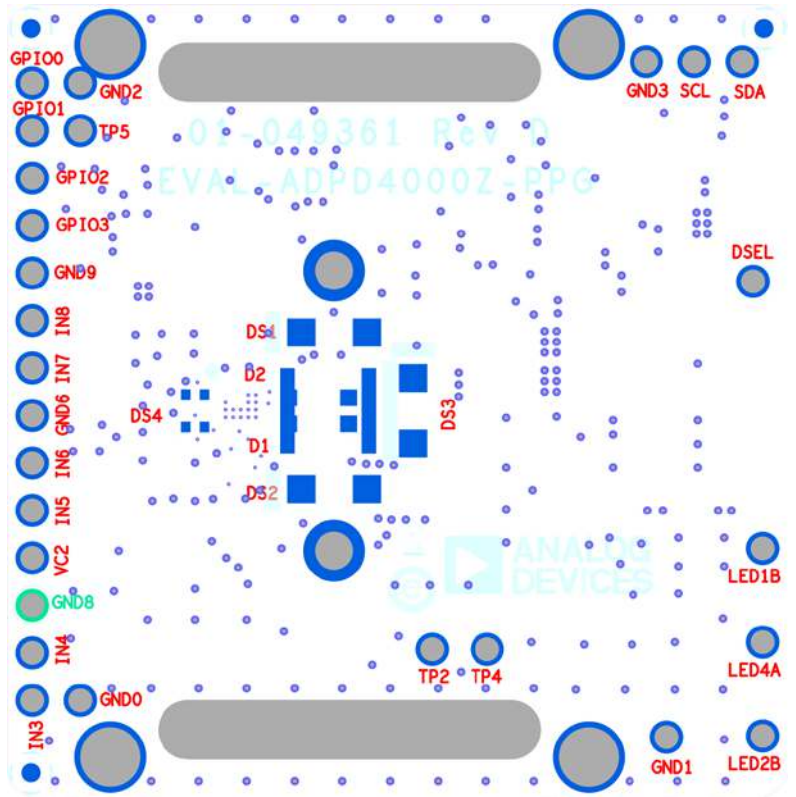
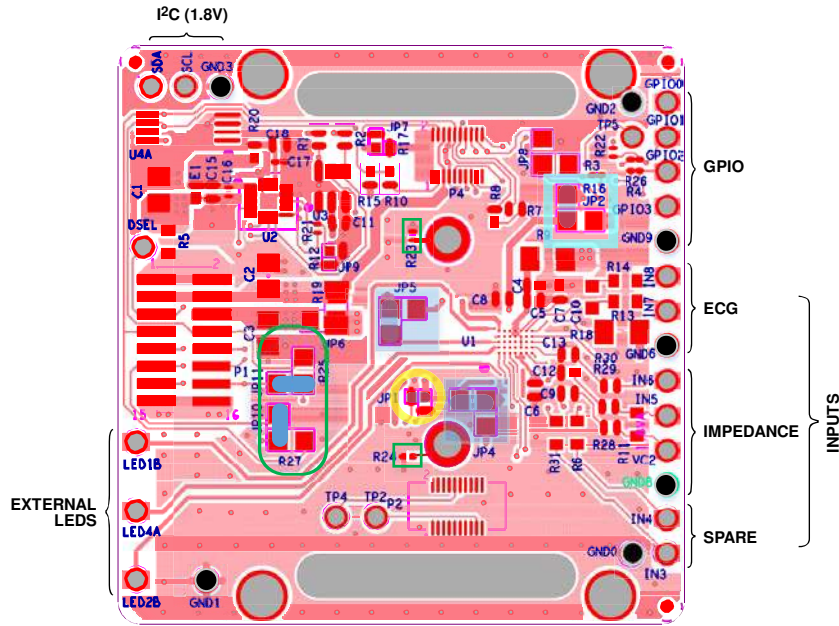

Figure 19. EVAL-ADPD4000Z-PPG Layout, Bottom Layer, Inverted Silkscreen View



- GROUND POINTS
- GROUND CONNECTION FOR METAL BAFFLEPOINTS
- DATA CONFIGURATION JUMPERS
 - SPI SELECTED
- GREEN LED DRIVER CHOICE
 - SEPARATE DRIVES SELECTED
- 3.3V OR 1.8V IO VOLTAGE CHOICE
 - 1.8V SELECTED
- PHOTODIODE CONNECT VC1 OR DIFFERENTIAL
 - VC1 SHOWN SELECTED
- MOUNTING HOLES AND STRAP SLOTS

Figure 20. EVAL-ADPD400Z-PPG, Jumpers and Connectors

20180-020

I²C refers to a communications protocol originally developed by Philips Semiconductors (now NXP Semiconductors).



ESD Caution

ESD (electrostatic discharge) sensitive device. Charged devices and circuit boards can discharge without detection. Although this product features patented or proprietary protection circuitry, damage may occur on devices subjected to high energy ESD. Therefore, proper ESD precautions should be taken to avoid performance degradation or loss of functionality.

Legal Terms and Conditions

By using the evaluation board discussed herein (together with any tools, components documentation or support materials, the "Evaluation Board"), you are agreeing to be bound by the terms and conditions set forth below ("Agreement") unless you have purchased the Evaluation Board, in which case the Analog Devices Standard Terms and Conditions of Sale shall govern. Do not use the Evaluation Board until you have read and agreed to the Agreement. Your use of the Evaluation Board shall signify your acceptance of the Agreement. This Agreement is made by and between you ("Customer") and Analog Devices, Inc. ("ADI"), with its principal place of business at One Technology Way, Norwood, MA 02062, USA. Subject to the terms and conditions of the Agreement, ADI hereby grants to Customer a free, limited, personal, temporary, non-exclusive, non-sublicensable, non-transferable license to use the Evaluation Board FOR EVALUATION PURPOSES ONLY. Customer understands and agrees that the Evaluation Board is provided for the sole and exclusive purpose referenced above, and agrees not to use the Evaluation Board for any other purpose. Furthermore, the license granted is expressly made subject to the following additional limitations: Customer shall not (i) rent, lease, display, sell, transfer, assign, sublicense, or distribute the Evaluation Board; and (ii) permit any Third Party to access the Evaluation Board. As used herein, the term "Third Party" includes any entity other than ADI, Customer, their employees, affiliates and in-house consultants. The Evaluation Board is NOT sold to Customer; all rights not expressly granted herein, including ownership of the Evaluation Board, are reserved by ADI. CONFIDENTIALITY. This Agreement and the Evaluation Board shall all be considered the confidential and proprietary information of ADI. Customer may not disclose or transfer any portion of the Evaluation Board to any other party for any reason. Upon discontinuation of use of the Evaluation Board or termination of this Agreement, Customer agrees to promptly return the Evaluation Board to ADI. ADDITIONAL RESTRICTIONS. Customer may not disassemble, decompile or reverse engineer chips on the Evaluation Board. Customer shall inform ADI of any occurred damages or any modifications or alterations it makes to the Evaluation Board, including but not limited to soldering or any other activity that affects the material content of the Evaluation Board. Modifications to the Evaluation Board must comply with applicable law, including but not limited to the RoHS Directive. TERMINATION. ADI may terminate this Agreement at any time upon giving written notice to Customer. Customer agrees to return to ADI the Evaluation Board at that time. LIMITATION OF LIABILITY. THE EVALUATION BOARD PROVIDED HEREUNDER IS PROVIDED "AS IS" AND ADI MAKES NO WARRANTIES OR REPRESENTATIONS OF ANY KIND WITH RESPECT TO IT. ADI SPECIFICALLY DISCLAIMS ANY REPRESENTATIONS, ENDORSEMENTS, GUARANTEES, OR WARRANTIES, EXPRESS OR IMPLIED, RELATED TO THE EVALUATION BOARD INCLUDING, BUT NOT LIMITED TO, THE IMPLIED WARRANTY OF MERCHANTABILITY, TITLE, FITNESS FOR A PARTICULAR PURPOSE OR NON-INFRINGEMENT OF INTELLECTUAL PROPERTY RIGHTS. IN NO EVENT WILL ADI AND ITS LICENSORS BE LIABLE FOR ANY INCIDENTAL, SPECIAL, INDIRECT, OR CONSEQUENTIAL DAMAGES RESULTING FROM CUSTOMER'S POSSESSION OR USE OF THE EVALUATION BOARD, INCLUDING BUT NOT LIMITED TO LOST PROFITS, DELAY COSTS, LABOR COSTS OR LOSS OF GOODWILL. ADI'S TOTAL LIABILITY FROM ANY AND ALL CAUSES SHALL BE LIMITED TO THE AMOUNT OF ONE HUNDRED US DOLLARS (\$100.00). EXPORT. Customer agrees that it will not directly or indirectly export the Evaluation Board to another country, and that it will comply with all applicable United States federal laws and regulations relating to exports. GOVERNING LAW. This Agreement shall be governed by and construed in accordance with the substantive laws of the Commonwealth of Massachusetts (excluding conflict of law rules). Any legal action regarding this Agreement will be heard in the state or federal courts having jurisdiction in Suffolk County, Massachusetts, and Customer hereby submits to the personal jurisdiction and venue of such courts. The United Nations Convention on Contracts for the International Sale of Goods shall not apply to this Agreement and is expressly disclaimed.