

**NOTES:**

- PLACE (1) ONE OF EACH KIT, IN A BAG WITH INSTRUCTION SHEET AND SEAL.
- LABEL WITH CONXALL, PART NUMBER, DATE CODE AND P/N BARCODE IS PLACED ON BAG.

ASSY P/N	I.D. FOR CABLE
SF3282-XESG-520	Ø 0.200
SF3282-XESG-530	Ø 0.300
SF3282-XESG-540	Ø 0.400

NO. OF CONTACTS: 4-12

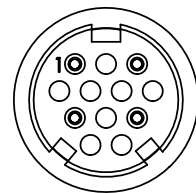

**SF3282-4ESG-5XX**  
FACE VIEW  
POS 2, 4, 6, 7, 9, 10,  
11 & 12 MOLDED  
HALF CLOSED

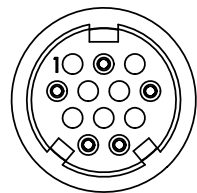

**SF3282-5ESG-5XX**  
FACE VIEW  
POS 1, 3, 5, 8, 10,  
11 & 12 MOLDED  
HALF CLOSED

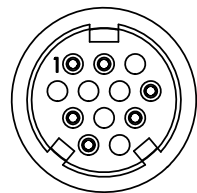

**SF3282-6ESG-5XX**  
FACE VIEW  
POS 3, 6, 9, 10,  
11 & 12 MOLDED  
HALF CLOSED

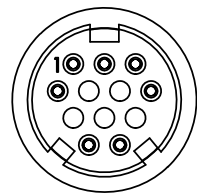

**SF3282-7ESG-5XX**  
FACE VIEW  
POS 5, 8, 10, 11  
& 12 MOLDED  
HALF CLOSED

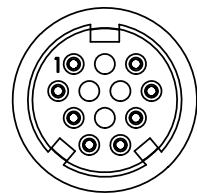

**SF3282-8ESG-5XX**  
FACE VIEW  
POS 2, 10, 11 & 12  
MOLDED HALF CLOSED

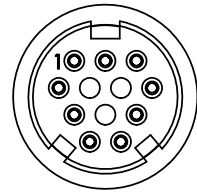

**SF3282-9ESG-5XX**  
FACE VIEW  
POS 10, 11 & 12  
MOLDED HALF CLOSED

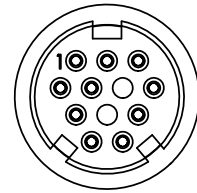

**SF3282-10ESG-5XX**  
FACE VIEW  
POS 11 & 12 MOLDED  
HALF CLOSED

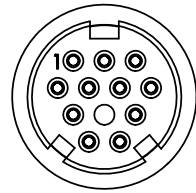

**SF3282-11ESG-5XX**  
FACE VIEW  
POS 12 MOLDED  
HALF CLOSED

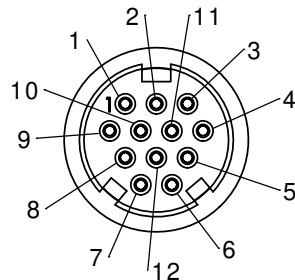

**SF3282-12ESG-5XX**  
FACE VIEW

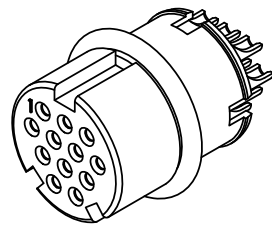
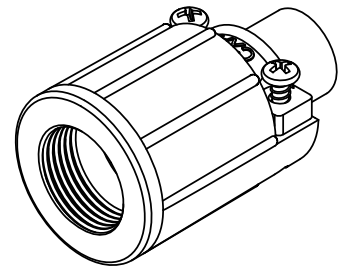

Ⓢ

**4-12 POSITION E-KEYING INSERT KIT**

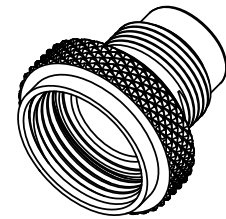
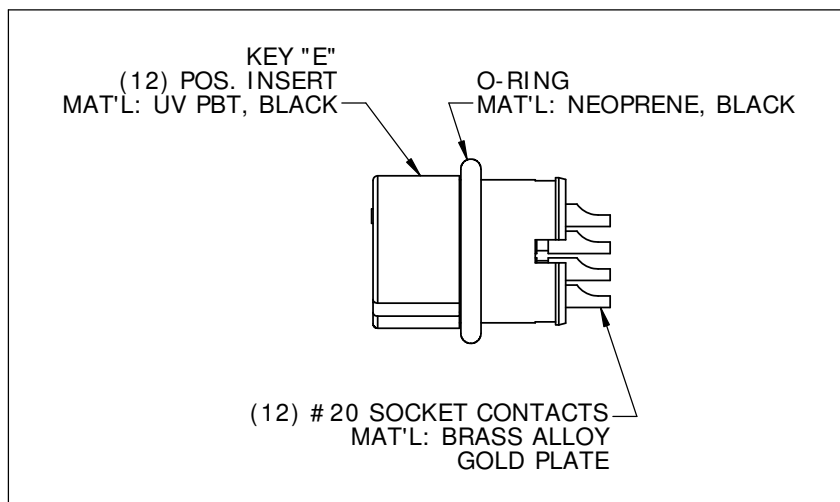

**HOUSING KIT**

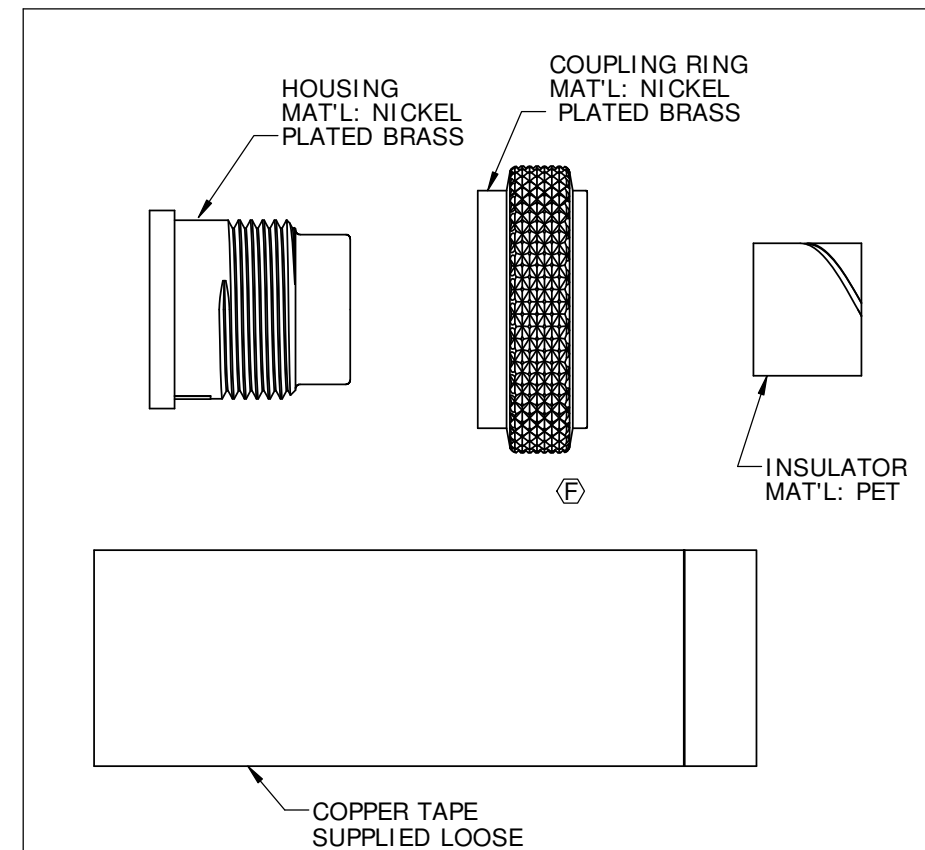

**BACKSHELL KIT**

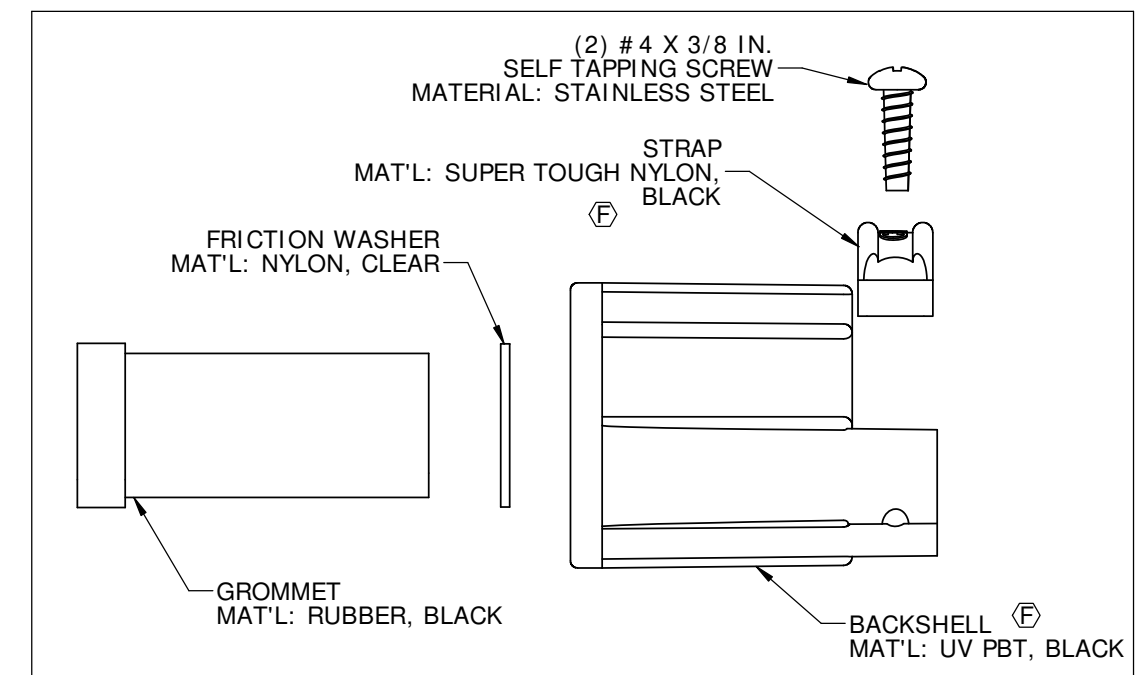

CUSTOMER PRINT

PART NUMBER: SF3282-XESG-5XX

**CUSTOMER APPROVAL**

THIS DOCUMENT CONTAINS CONFIDENTIAL INFORMATION PROPRIETARY TO CONXALL CORPORATION. ANY REPRODUCTION, DISCLOSURE, OR USE OF THIS DOCUMENT / INFORMATION IS EXPRESSLY PROHIBITED UNLESS AUTHORIZED IN WRITING BY CONXALL CORPORATION.

APPROVED BY: \_\_\_\_\_  
DATE: \_\_\_\_\_

F	MA	10-03-19	SUPERSEDES SF3282-12ESG-5XX. ADDED SF3282-XESG-530 TO CHART. UPDATED BACKSHELL, STRAP, INSERT AND INSULATOR MATERIALS. ADDED FACE VIEWS FOR INSERT PER ECR 9439
E	MA	08-28-17	UPDATED PACKAGING PER ECR 9013
D	AN	01-26-15	INSERT MATERIAL COLOR WAS DARK GRAY PER ECR 8811
C	PD	12-14-12	KITS WERE BULK PACKED PER ECR 8361, UPDATE MANUFACTURING DRAWING PER ECR 8385
REV.	INIT.	DATE	DESCRIPTION
	AN	08-17-11	ALL INFORMATION ILLUSTRATED IS THE PROPERTY OF CONXALL CORPORATION. UNAUTHORIZED DUPLICATION OR DISTRIBUTION OF THIS DOCUMENT IS PROHIBITED.
			ALL UNITS ARE IN FEET, INCHES, FRACTION OF INCHES AND DECIMALS.
SCALE		SIZE	SHEET
NTS		B	1 OF 1
FILE:	DIRECTORY:	PART NUMBER:	REV
SF3282-XESG-5XX	SLW	SF3282-XESG-5XX	F

**RoHS COMPLIANT**



601 E. WILDWOOD VILLA PARK, IL 60181  
TITLE: CONNECTOR ASSEMBLY KIT  
(4-12) SOCKET CONTACTS  
SHIELDED MULTI-CON-X  
STANDARD PRODUCT