



MICROCHIP

MCP1711
Demonstration Board
User's Guide

Note the following details of the code protection feature on Microchip devices:

- Microchip products meet the specification contained in their particular Microchip Data Sheet.
- Microchip believes that its family of products is one of the most secure families of its kind on the market today, when used in the intended manner and under normal conditions.
- There are dishonest and possibly illegal methods used to breach the code protection feature. All of these methods, to our knowledge, require using the Microchip products in a manner outside the operating specifications contained in Microchip's Data Sheets. Most likely, the person doing so is engaged in theft of intellectual property.
- Microchip is willing to work with the customer who is concerned about the integrity of their code.
- Neither Microchip nor any other semiconductor manufacturer can guarantee the security of their code. Code protection does not mean that we are guaranteeing the product as "unbreakable."

Code protection is constantly evolving. We at Microchip are committed to continuously improving the code protection features of our products. Attempts to break Microchip's code protection feature may be a violation of the Digital Millennium Copyright Act. If such acts allow unauthorized access to your software or other copyrighted work, you may have a right to sue for relief under that Act.

Information contained in this publication regarding device applications and the like is provided only for your convenience and may be superseded by updates. It is your responsibility to ensure that your application meets with your specifications. MICROCHIP MAKES NO REPRESENTATIONS OR WARRANTIES OF ANY KIND WHETHER EXPRESS OR IMPLIED, WRITTEN OR ORAL, STATUTORY OR OTHERWISE, RELATED TO THE INFORMATION, INCLUDING BUT NOT LIMITED TO ITS CONDITION, QUALITY, PERFORMANCE, MERCHANTABILITY OR FITNESS FOR PURPOSE. Microchip disclaims all liability arising from this information and its use. Use of Microchip devices in life support and/or safety applications is entirely at the buyer's risk, and the buyer agrees to defend, indemnify and hold harmless Microchip from any and all damages, claims, suits, or expenses resulting from such use. No licenses are conveyed, implicitly or otherwise, under any Microchip intellectual property rights unless otherwise stated.

Trademarks

The Microchip name and logo, the Microchip logo, dsPIC, FlashFlex, flexPWR, JukeBlox, KEELOQ, KEELOQ logo, Kleer, LANCheck, MediaLB, MOST, MOST logo, MPLAB, OptoLyzer, PIC, PICSTART, PIC³² logo, RightTouch, SpyNIC, SST, SST Logo, SuperFlash and UNI/O are registered trademarks of Microchip Technology Incorporated in the U.S.A. and other countries.

The Embedded Control Solutions Company and mTouch are registered trademarks of Microchip Technology Incorporated in the U.S.A.

Analog-for-the-Digital Age, BodyCom, chipKIT, chipKIT logo, CodeGuard, dsPICDEM, dsPICDEM.net, ECAN, In-Circuit Serial Programming, ICSP, Inter-Chip Connectivity, KleerNet, KleerNet logo, MiWi, motorBench, MPASM, MPF, MPLAB Certified logo, MPLIB, MPLINK, MultiTRAK, NetDetach, Omniscient Code Generation, PICDEM, PICDEM.net, PICkit, PICtail, RightTouch logo, REAL ICE, SQI, Serial Quad I/O, Total Endurance, TSHARC, USBCheck, VariSense, ViewSpan, WiperLock, Wireless DNA, and ZENA are trademarks of Microchip Technology Incorporated in the U.S.A. and other countries.

SQTP is a service mark of Microchip Technology Incorporated in the U.S.A.

Silicon Storage Technology is a registered trademark of Microchip Technology Inc. in other countries.

GestIC is a registered trademark of Microchip Technology Germany II GmbH & Co. KG, a subsidiary of Microchip Technology Inc., in other countries.

All other trademarks mentioned herein are property of their respective companies.

© 2015, Microchip Technology Incorporated, Printed in the U.S.A., All Rights Reserved.

ISBN: 978-1-63277-728-7

**QUALITY MANAGEMENT SYSTEM
CERTIFIED BY DNV
= ISO/TS 16949 =**

Microchip received ISO/TS-16949:2009 certification for its worldwide headquarters, design and wafer fabrication facilities in Chandler and Tempe, Arizona; Gresham, Oregon and design centers in California and India. The Company's quality system processes and procedures are for its PIC[®] MCUs and dsPIC[®] DSCs, KEELOQ[®] code hopping devices, Serial EEPROMs, microperipherals, nonvolatile memory and analog products. In addition, Microchip's quality system for the design and manufacture of development systems is ISO 9001:2000 certified.

Object of Declaration: MCP1711 Demonstration Board

EU Declaration of Conformity

Manufacturer: Microchip Technology Inc.
2355 W. Chandler Blvd.
Chandler, Arizona, 85224-6199
USA

This declaration of conformity is issued by the manufacturer.

The development/evaluation tool is designed to be used for research and development in a laboratory environment. This development/evaluation tool is not a Finished Appliance, nor is it intended for incorporation into Finished Appliances that are made commercially available as single functional units to end users under EU EMC Directive 2004/108/EC and as supported by the European Commission's Guide for the EMC Directive 2004/108/EC (8th February 2010).

This development/evaluation tool complies with EU RoHS2 Directive 2011/65/EU.

This development/evaluation tool, when incorporating wireless and radio-telecom functionality, is in compliance with the essential requirement and other relevant provisions of the R&TTE Directive 1999/5/EC and the FCC rules as stated in the declaration of conformity provided in the module datasheet and the module product page available at www.microchip.com.

For information regarding the exclusive, limited warranties applicable to Microchip products, please see Microchip's standard terms and conditions of sale, which are printed on our sales documentation and available at www.microchip.com.

Signed for and on behalf of Microchip Technology Inc. at Chandler, Arizona, USA

Derek Carlson
VP Development Tools

12-Sep-14
Date

NOTES:



MCP1711 DEMONSTRATION BOARD USER'S GUIDE

Table of Contents

Preface	7
Chapter 1. Product Overview	
1.1 Introduction	11
1.2 MCP1711 Short Overview	11
1.2.1 MCP1711 Key Features	11
1.2.2 MCP1711 Overview	11
1.3 What is the MCP1711 Demo Board?	12
1.4 MCP1711 Demo Board Kit Contents	14
Chapter 2. Installation and Operation	
2.1 Getting Started	15
2.2 Power Input and Output Connections	15
2.2.1 Powering the MCP1711 Demo Board	15
2.3 Board Testing	16
Appendix A. Schematics and Layouts	
A.1 Introduction	17
A.2 Board - Schematic (5-Lead SOT-23 Part)	18
A.3 Board - Schematic (4-Lead 1x1 UQFN Part)	18
A.4 Board - Top Silk	19
A.5 Board - Top Copper and Silk	19
A.6 Board - Top Copper	20
A.7 Board - Bottom Copper	20
A.8 Board - Bottom Copper and Silk	21
A.9 Board - Bottom Silk	21
Appendix B. Bill of Materials (BOM)	23
Worldwide Sales and Service	24

MCP1711 Demonstration Board User's Guide

NOTES:



MCP1711 DEMONSTRATION BOARD USER'S GUIDE

Preface

NOTICE TO CUSTOMERS

All documentation becomes dated, and this manual is no exception. Microchip tools and documentation are constantly evolving to meet customer needs, so some actual dialogs and/or tool descriptions may differ from those in this document. Please refer to our web site (www.microchip.com) to obtain the latest documentation available.

Documents are identified with a “DS” number. This number is located on the bottom of each page, in front of the page number. The numbering convention for the DS number is “DSXXXXXXXXA”, where “XXXXXXXX” is the document number and “A” is the revision level of the document.

For the most up-to-date information on development tools, see the MPLAB® IDE online help. Select the Help menu, and then Topics to open a list of available online help files.

INTRODUCTION

This chapter contains general information that will be useful to know before using the MCP1711 Demo Board. Items discussed in this chapter include:

- Document Layout
- Conventions Used in this Guide
- Recommended Reading
- The Microchip Web Site
- Customer Support
- Document Revision History

DOCUMENT LAYOUT

This document describes how to use the MCP1711 Demo Board as a development tool to emulate and debug firmware on a target board, as well as how to program devices. The document is organized as follows:

- **Chapter 1. “Product Overview”** – Provides important information about the MCP1711 Demo Board and shows the hardware details of its components.
- **Chapter 2. “Installation and Operation”** – Includes instructions on how to use, power and test the MCP1711 Demo Board.
- **Appendix A. “Schematics and Layouts”** – Shows the schematic and layout diagrams for the MCP1711 Demo Board.
- **Appendix B. “Bill of Materials (BOM)”** – Lists the parts used to build the MCP1711 Demo Board.

MCP1711 Demonstration Board User's Guide

CONVENTIONS USED IN THIS GUIDE

This manual uses the following documentation conventions:

DOCUMENTATION CONVENTIONS

Description	Represents	Examples
Arial font:		
Italic characters	Referenced books	<i>MPLAB[®] IDE User's Guide</i>
	Emphasized text	...is the <i>only</i> compiler...
Initial caps	A window	the Output window
	A dialog	the Settings dialog
	A menu selection	select Enable Programmer
Quotes	A field name in a window or dialog	"Save project before build"
Underlined, italic text with right angle bracket	A menu path	<u><i>File>Save</i></u>
Bold characters	A dialog button	Click OK
	A tab	Click the Power tab
N'Rnnnn	A number in verilog format, where N is the total number of digits, R is the radix and n is a digit.	4'b0010, 2'hF1
Text in angle brackets < >	A key on the keyboard	Press <Enter>, <F1>
Courier New font:		
Plain Courier New	Sample source code	<code>#define START</code>
	Filenames	<code>autoexec.bat</code>
	File paths	<code>c:\mcc18\h</code>
	Keywords	<code>_asm, _endasm, static</code>
	Command-line options	<code>-Opa+, -Opa-</code>
	Bit values	<code>0, 1</code>
	Constants	<code>0xFF, 'A'</code>
Italic Courier New	A variable argument	<i>file.o</i> , where <i>file</i> can be any valid filename
Square brackets []	Optional arguments	<code>mcc18 [options] file [options]</code>
Curly brackets and pipe character: { }	Choice of mutually exclusive arguments; an OR selection	<code>errorlevel {0 1}</code>
Ellipses...	Replaces repeated text	<code>var_name [, var_name...]</code>
	Represents code supplied by user	<code>void main (void) { ... }</code>

RECOMMENDED READING

This user's guide describes how to use the MCP1711 Demo Board. Another useful document is listed below. The following Microchip document is available and recommended as a supplemental reference resource:

- **MCP1711 Data Sheet – “150 mA Ultra-Low Quiescent Current, Capacitorless LDO Regulator” (DS20005415)**

THE MICROCHIP WEB SITE

Microchip provides online support via our web site at www.microchip.com. This web site is used as a means to make files and information easily available to customers. Accessible by using your favorite Internet browser, the web site contains the following information:

- **Product Support** – Data sheets and errata, application notes and sample programs, design resources, user's guides and hardware support documents, latest software releases and archived software
- **General Technical Support** – Frequently Asked Questions (FAQs), technical support requests, online discussion groups, Microchip consultant program member listing
- **Business of Microchip** – Product selector and ordering guides, latest Microchip press releases, listing of seminars and events, listings of Microchip sales offices, distributors and factory representatives

CUSTOMER SUPPORT

Users of Microchip products can receive assistance through several channels:

- Distributor or Representative
- Local Sales Office
- Field Application Engineer (FAE)
- Technical Support

Customers should contact their distributor, representative or field application engineer (FAE) for support. Local sales offices are also available to help customers. A listing of sales offices and locations is included in the back of this document.

Technical support is available through the web site at:

<http://www.microchip.com/support>.

DOCUMENT REVISION HISTORY

Revision A (September 2015)

- Initial release of this document.

MCP1711 Demonstration Board User's Guide

NOTES:

Chapter 1. Product Overview

1.1 INTRODUCTION

This chapter provides an overview of the MCP1711 Demo Board and covers the following topics:

- MCP1711 Short Overview
- What is the MCP1711 Demo Board?
- MCP1711 Demo Board Kit Contents

1.2 MCP1711 SHORT OVERVIEW

1.2.1 MCP1711 Key Features

The key features of the MCP1711 include:

- Input operating voltage range: 1.4V to 6V
- Ultra-low 0.6 μ A (typical) quiescent current
- Ultra-low Shutdown supply current: 10 nA (typical)
- 150 mA output current capability for all input operating voltage range
- Standard output voltages (V_R): 1.2V, 1.8V, 2.5V, 3.3V, 4.2V, 5.0V
- Stable with no output capacitor (1.0 μ F or more recommended for better transient response)
- Protection circuits: current limiter, short circuit, foldback
- Available packages:
 - 4-Lead 1 x 1 mm UQFN
 - 5-Lead SOT-23

1.2.2 MCP1711 Overview

The MCP1711 device has been developed to provide ultra-low power applications with a precise, regulated rail. It is a highly-accurate CMOS low dropout (LDO) voltage regulator that can deliver up to 150 mA of current while consuming only 0.6 μ A of quiescent current (typical). The input operating range is specified from 1.4V to 6.0V, making it an ideal choice for mobile applications and one-cell Li-Ion-powered applications.

The MCP1711 is capable of delivering 150 mA output current with only 0.32V (typical) for $V_R = 5.0V$, and 1.41V (typical) for $V_R = 1.2V$ of input-to-output voltages differential. The output voltage accuracy of the MCP1711 is typically $\pm 0.02V$ for $V_R < 2.0V$ and $\pm 1\%$ for $V_R > 2.0V$ at $+25^\circ C$. The temperature stability is about ± 50 ppm/ $^\circ C$. Line regulation is $\pm 0.01\%/V$ typical at $+25^\circ C$.

MCP1711 Demonstration Board User's Guide

The output voltages available for the MCP1711 device range from 1.2V to 5.0V. The LDO output is stable even if an output capacitor is not connected, due to an excellent internal phase compensation. However, for better transient responses, the output capacitor should be used. The MCP1711 is compatible with low equivalent series resistance (ESR) ceramic output capacitors.

Overcurrent limit and short circuit protection embedded into the device provide a robust solution for any application.

The MCP1711 has a true current foldback feature. When the load increases beyond the MCP1711 load rating, the output current and output voltage will foldback toward 80 mA (typical) at about 0V output. When the load impedance increases and returns to the rated load, the MCP1711 will follow the same foldback curve as the device comes out of current foldback.

If the device is in Shutdown mode, by inputting a low-level signal to the $\overline{\text{SHDN}}$ pin, the current consumption is reduced to less than 0.1 μA (typically 0.01 μA). In Shutdown mode, if the output capacitor is used, it will be discharged via the internal dedicated switch and, as a result, the output voltage quickly returns to 0V.

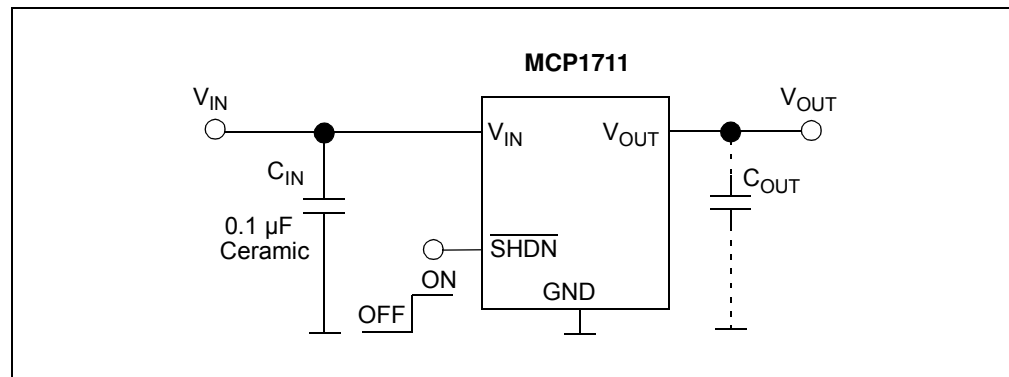

FIGURE 1-1: Typical Application Circuit.

1.3 WHAT IS THE MCP1711 DEMO BOARD?

The MCP1711 Demo Board has been developed to demonstrate the capabilities of the MCP1711 device with two voltage options and two package options:

- 1.8V in 5-Lead SOT-23
- 3.3V in 4-Lead 1x1 UQFN

Two circuits have been developed on the same board; they are electrically isolated and can be tested independently. Thus the MCP1711 Demo Board is meant to show how the MCP1711 device operates over a wide input voltage and load range.

Test points for input voltage and output voltage are provided to demonstrate the capability of the demo board over the entire range, allowing the board to be connected directly to a system.

The MCP1711 device can also be used without any input and output capacitors. To test the capacitorless feature, remove the C_{IN} and C_{OUT} capacitors from the desired circuit using a soldering iron set to 400°C or a hot-air gun set to the same temperature. Take care not to damage the LDOs in the process.

CAUTION

Removing the capacitors can damage them. For further usage, it is recommended to resolder untouched capacitors.

The board is equipped with a 3-pin 2.54 mm male header to allow the MCP1711 to be shut down or enabled with a jumper. To enable the device without an external signal, connect a jumper between the pins indicated by the EN silkscreen.

The MCP1711 can also be enabled and disabled by applying an external voltage (V_{EN}) between the second and the third terminals of this header.

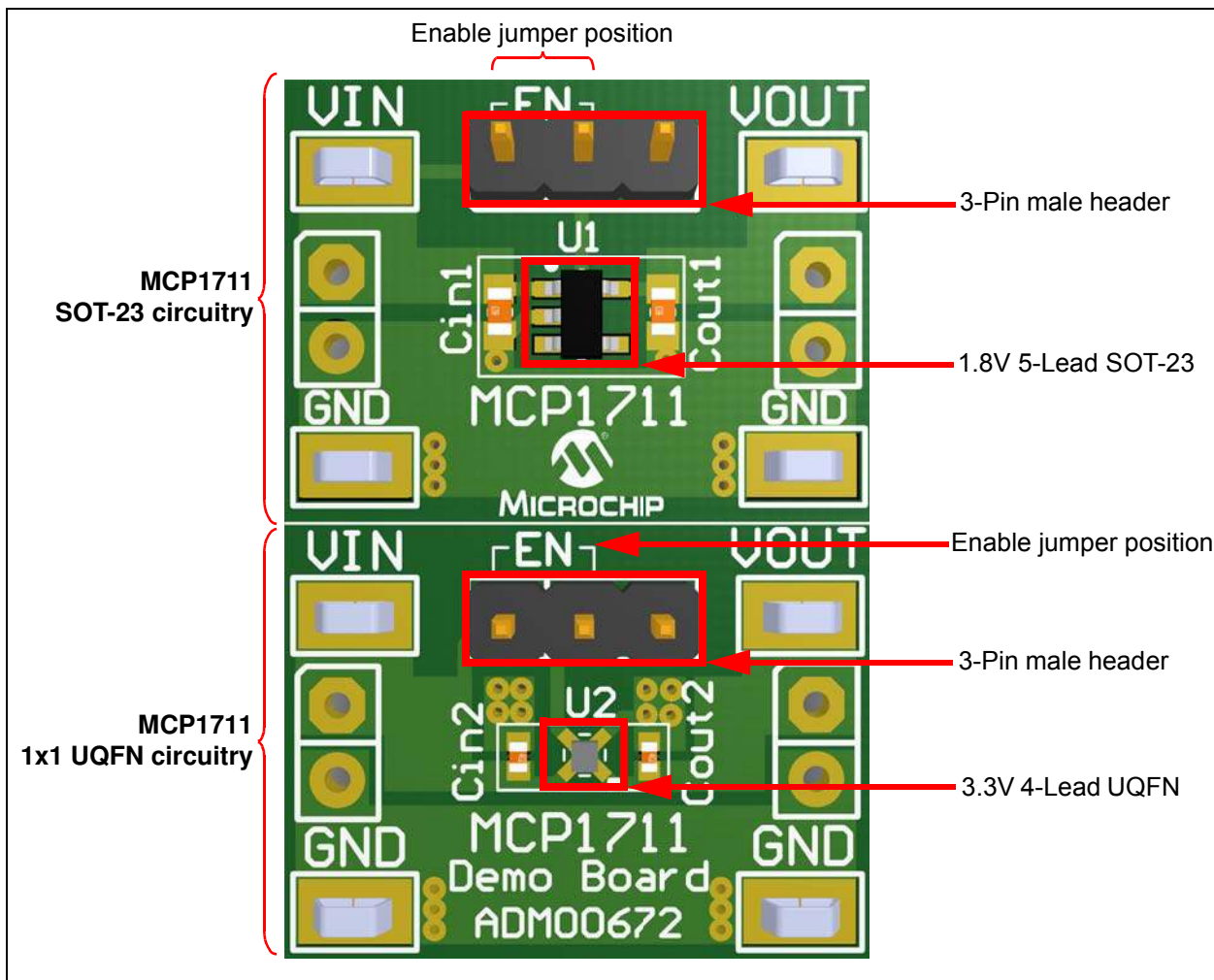

FIGURE 1-2: MCP1711 Demo Board - 3D Top View.

When V_{EN} is higher than 0.91V, the MCP1711 is turned on. When the V_{EN} voltage is less than 0.38V, the device output is turned off.

It is strongly recommended not to leave the \overline{SHDN} pin floating as this will cause output voltage instability.

The MCP1711 Demo Board is designed to operate from 3.2V to 6.0V input voltage when $V_R = 1.8V$ (SOT-23) and from 4.0V to 6.0V input voltage when $V_R = 3.3V$ (1x1 UQFN) and regulate the output voltage to the specified value over the entire current and temperature range.

The MCP1711 Demo Board was designed using small surface-mount components to show power supply size for ultra-low power, high-current applications.

If space-saving is a priority, the MCP1711 is stable even if an output capacitor is not present, reducing cost and board area.

MCP1711 Demonstration Board User's Guide

1.4 MCP1711 DEMO BOARD KIT CONTENTS

This MCP1711 Demo Board kit includes the following items:

- MCP1711 Demo Board (ADM00672)
- Important Information Sheet

Chapter 2. Installation and Operation

2.1 GETTING STARTED

The following sections describe how to use the MCP1711 Demo Board to fully evaluate and demonstrate the capabilities of the MCP1711 device.

2.2 POWER INPUT AND OUTPUT CONNECTIONS

2.2.1 Powering the MCP1711 Demo Board

The MCP1711 Demo Board is fully assembled, tested and ready to begin evaluating the MCP1711 device.

Apply positive input voltage to the desired V_{IN} terminal on the demonstration board and its return to the corresponding GND terminal. The maximum input voltage should not exceed 6.0V.

An electronic load or resistive load can be used to evaluate the MCP1711 Demo Board or the intended system load can be connected. Electronic loads can attempt to sink current at 0V during start-up, therefore a resistive load or constant resistance electronic load is recommended for start-up evaluation. **Do not use** the electronic load in Constant Current mode.

Connect the positive voltage terminal of the load at the V_{OUT} terminal on the demonstration board, and connect the negative, or return side of the load, to the corresponding GND terminal.

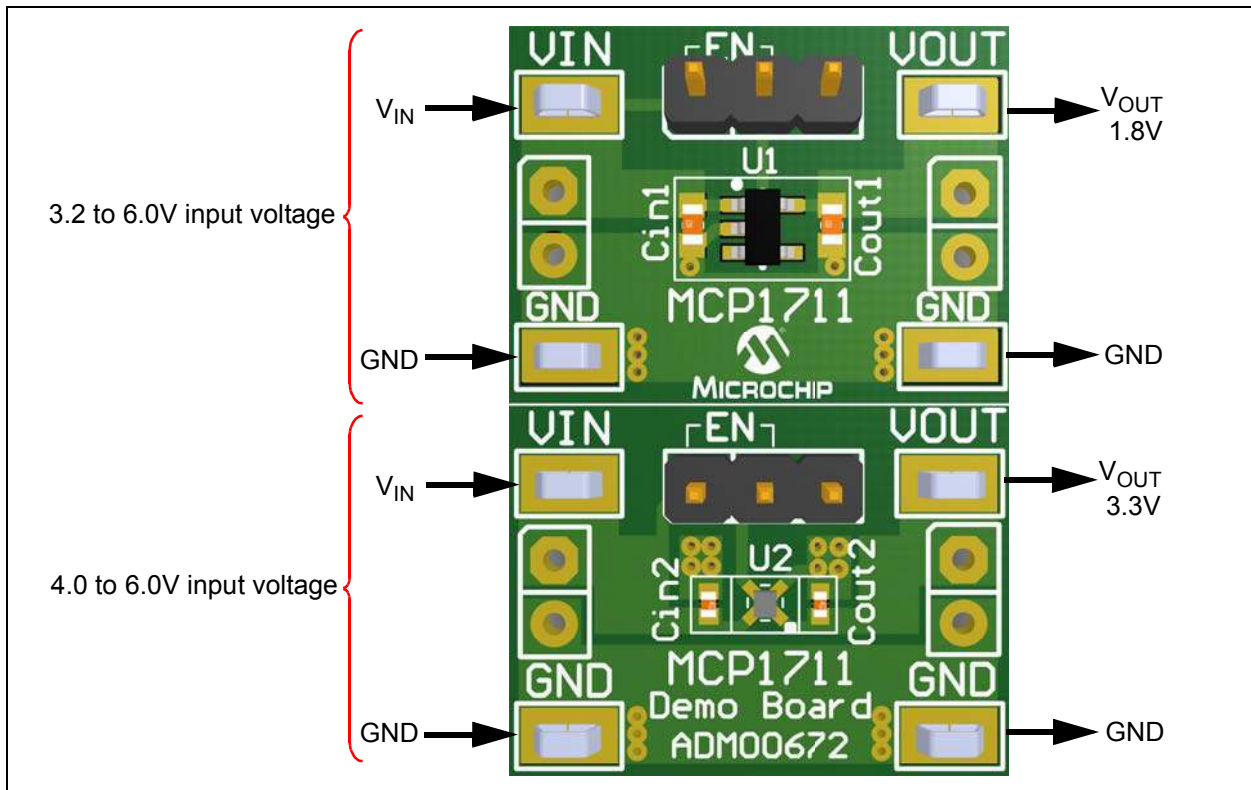

FIGURE 2-1: MCP1711 Demo Board - Powering Sequence.

2.3 BOARD TESTING

To test the board, follow these steps:

1. Apply input voltage.
2. If the EN jumper is connected as indicated in [Figure 1-2](#) in [Chapter 1. "Product Overview"](#), the output voltage of MCP1711 will start to rise and it will stabilize after some time, depending on the output current.
3. Adjusting the input voltage and load should not cause the output to vary over the operating range of the linear regulator by more than a few tens of mV, in a steady state condition.



MCP1711 DEMONSTRATION BOARD USER'S GUIDE

Appendix A. Schematics and Layouts

A.1 INTRODUCTION

This Appendix contains the following schematics and layouts for the MCP1711 Demo Board (ADM00672):

- Board - Schematic (5-Lead SOT-23 Part)
- Board - Schematic (4-Lead 1x1 UQFN Part)
- Board - Top Silk
- Board - Top Copper and Silk
- Board - Top Copper
- Board - Bottom Copper
- Board - Bottom Copper and Silk
- Board - Bottom Silk

MCP1711 Demonstration Board User's Guide

A.2 BOARD - SCHEMATIC (5-LEAD SOT-23 PART)

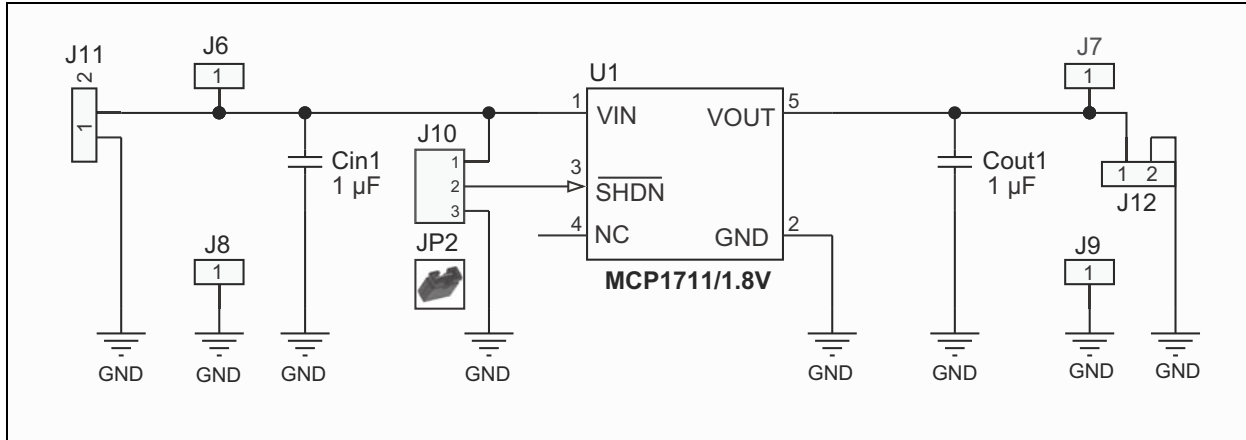

A.3 BOARD - SCHEMATIC (4-LEAD 1X1 UQFN PART)

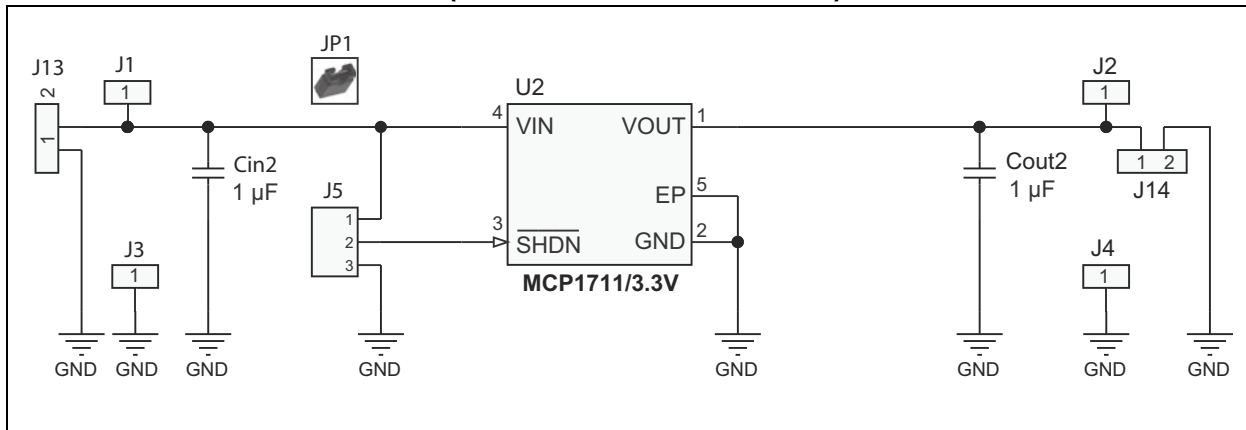

A.4 BOARD - TOP SILK

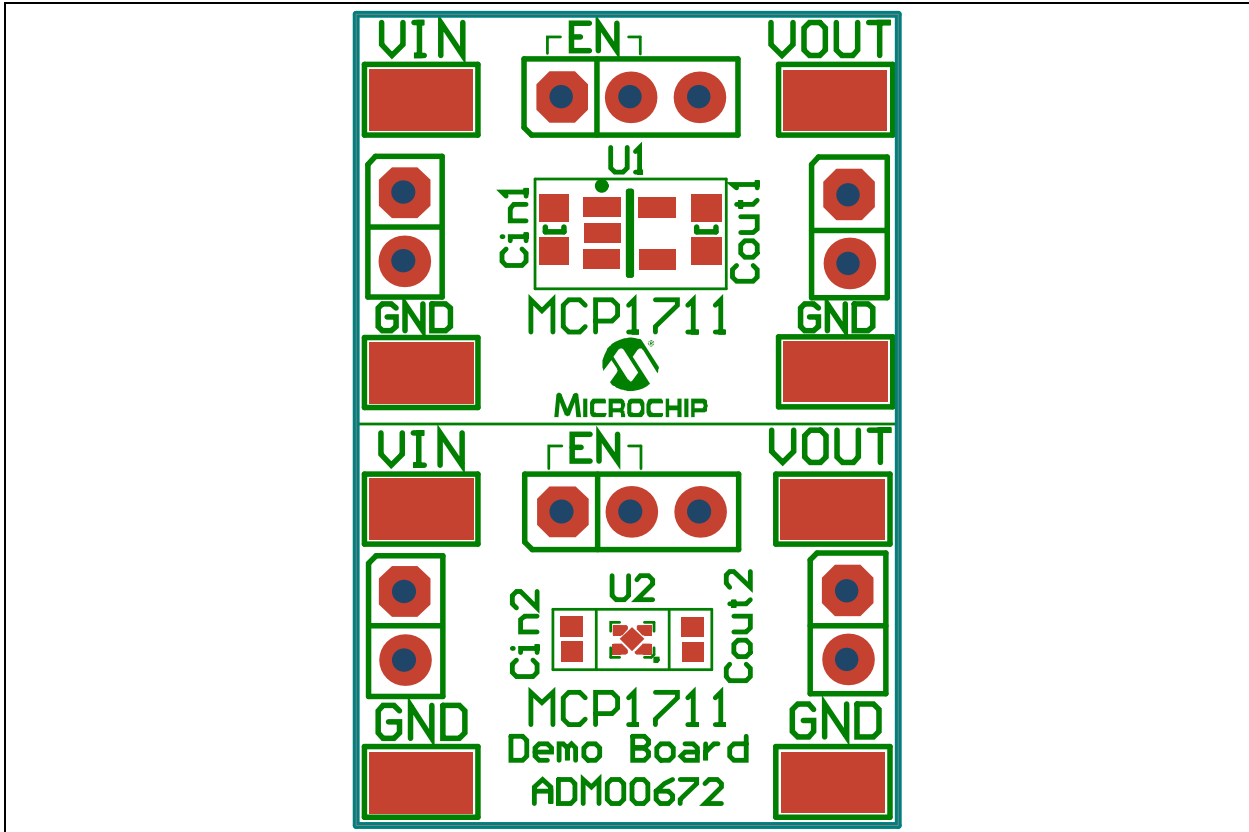

A.5 BOARD - TOP COPPER AND SILK

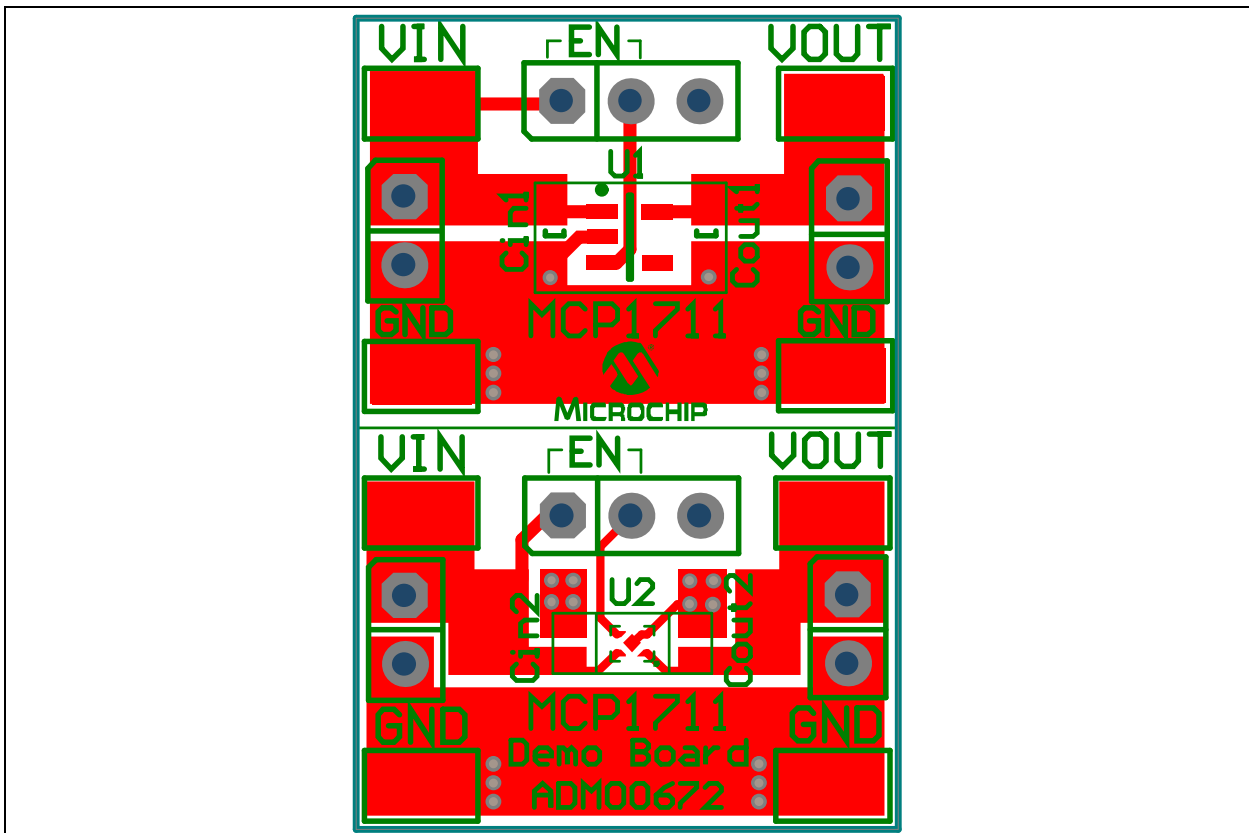

MCP1711 Demonstration Board User's Guide

A.6 BOARD - TOP COPPER

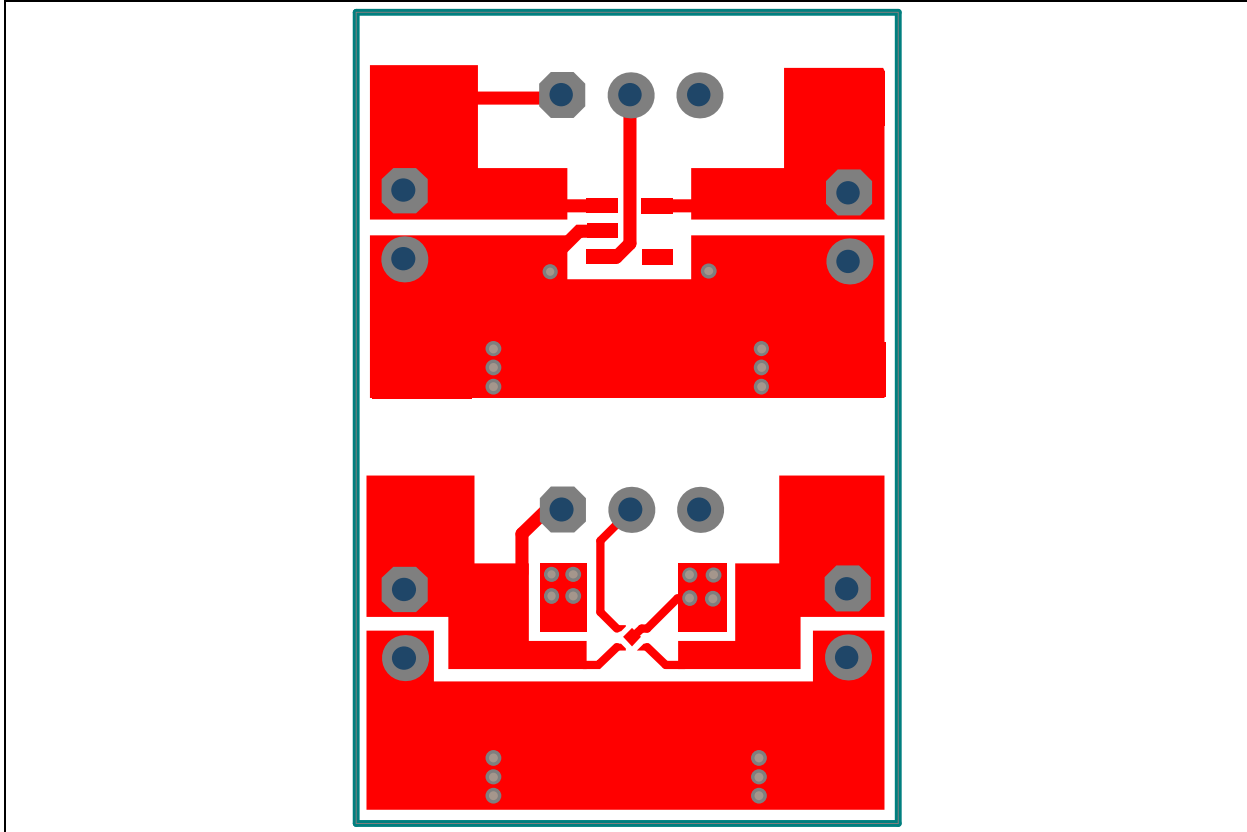

A.7 BOARD - BOTTOM COPPER

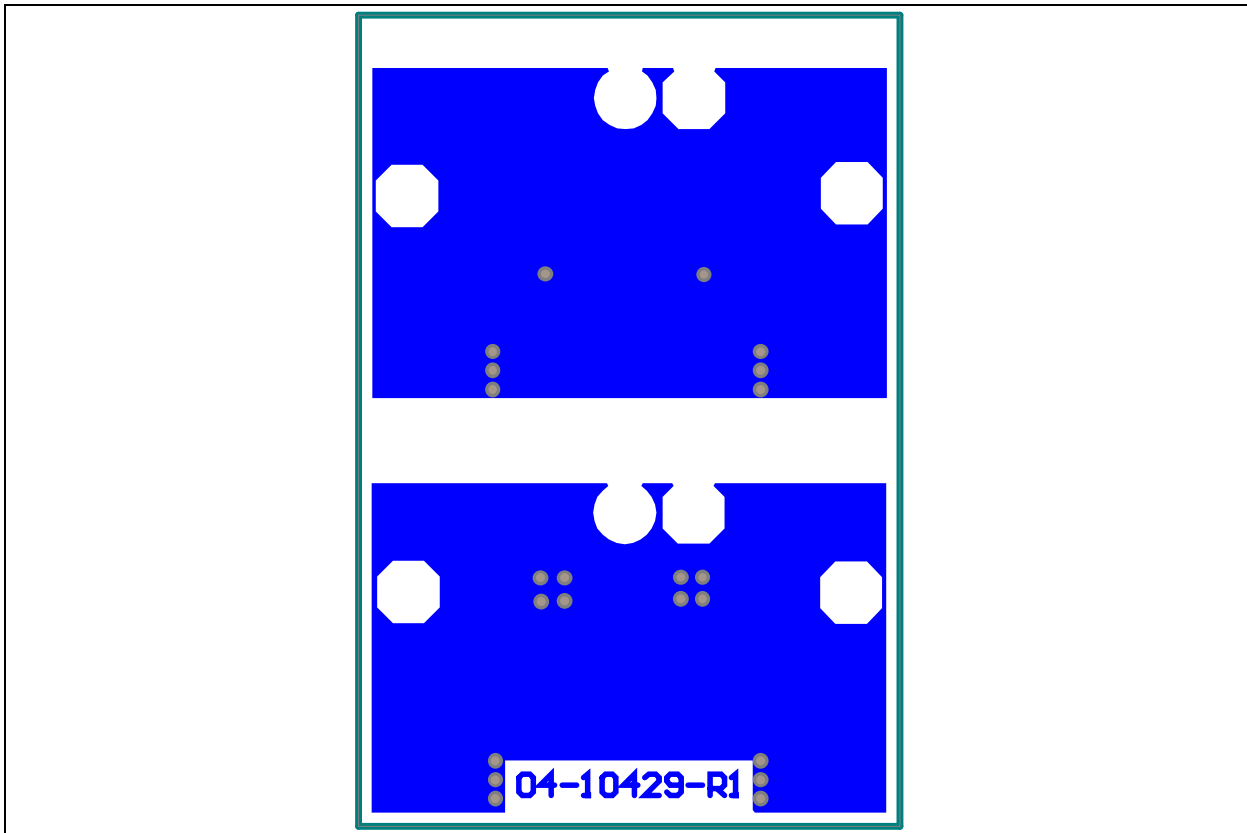

A.8 BOARD - BOTTOM COPPER AND SILK

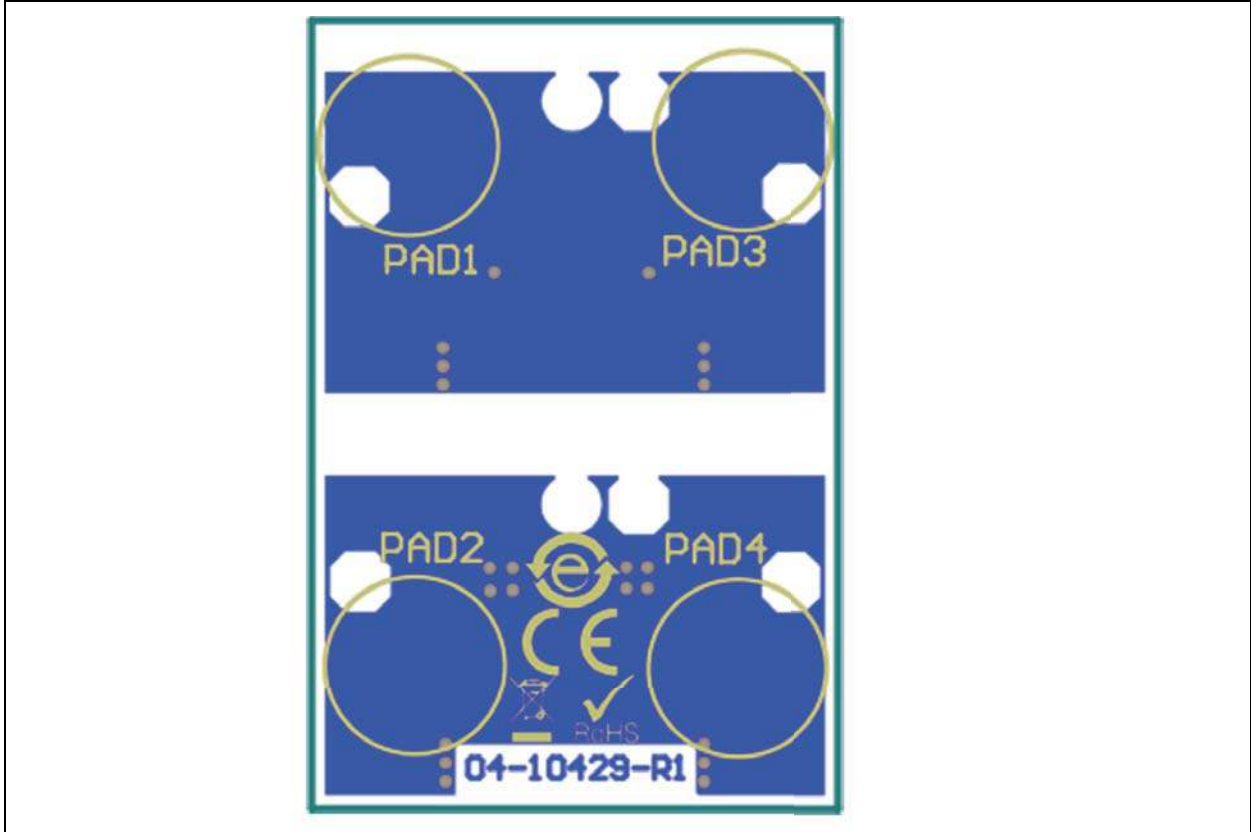

A.9 BOARD - BOTTOM SILK

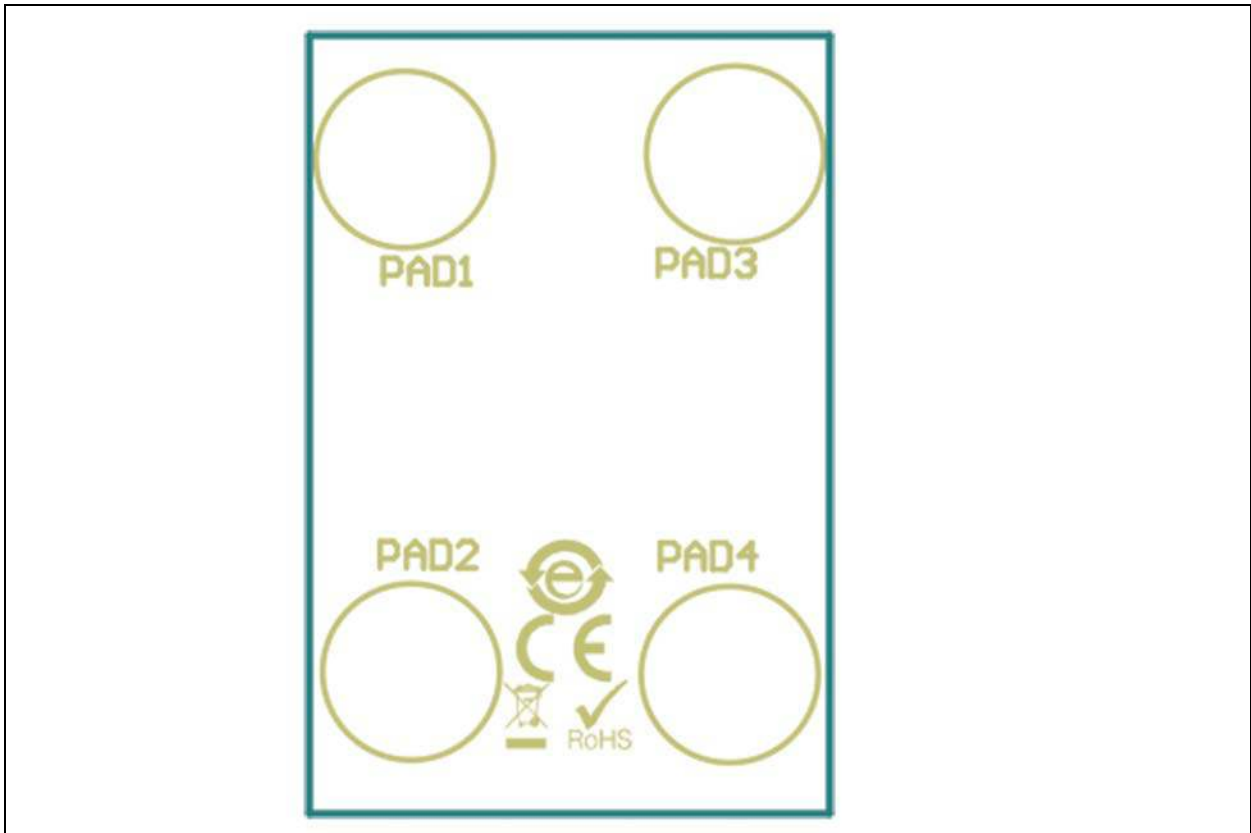

MCP1711 Demonstration Board User's Guide

NOTES:



MCP1711 DEMONSTRATION BOARD USER'S GUIDE

Appendix B. Bill of Materials (BOM)

TABLE B-1: BILL OF MATERIALS (BOM)

Qty.	Reference	Description	Manufacturer	Part Number
2	Cin1, Cout1	Cap. ceramic 1 μ F 16V 10% X5R SMD 0402	TDK Corporation	C1005X5R1C105K
2	Cin2, Cout2	Cap. ceramic 1 μ F 25V 10% X7R SMD 0603	TDK Corporation	C1608X7R1E105K
8	J1, J2, J3, J4, J6, J7, J8, J9	Conn. TP Loop Tin SMD	Harwin Plc.	S1751-46R
2	J5, J10	Conn. header-2.54 male 1x3 Tin 5.84 MH TH vert.	Samtec, Inc.	TSW-103-07-T-S
0	J11, J13	DO NOT POPULATE	—	—
0	J12, J14	DO NOT POPULATE	—	—
2	JP1, JP2	Mech. HW jumper 2.54 mm 1x2	3M	969102-0000-DA
1	PCB	MCP1711 1.8 VOUT /3.3VOUT Printed Circuit Board	—	04-10429-R1
1	U1	150 mA Capacitorless Ultra-low Quiescent Current LDO 5-Lead SOT-23	Microchip Technology Inc.	MCP1711T-18I/OT
1	U2	150 mA Capacitorless Ultra-low Quiescent Current LDO 4-Lead UQFN	Microchip Technology Inc.	MCP1711T-33I/5X
4	PAD1, PAD2, PAD3, PAD4	Mech. HW Rubber Pad Hemisphere D6.4 H1.9 Clear	3M	SJ5382

Note: The components listed in this Bill of Materials are representative of the PCB assembly. The released BOM used in manufacturing uses all RoHS-compliant components.



MICROCHIP

Worldwide Sales and Service

AMERICAS

Corporate Office
2355 West Chandler Blvd.
Chandler, AZ 85224-6199
Tel: 480-792-7200
Fax: 480-792-7277
Technical Support:
<http://www.microchip.com/support>
Web Address:
www.microchip.com

Atlanta
Duluth, GA
Tel: 678-957-9614
Fax: 678-957-1455

Austin, TX
Tel: 512-257-3370

Boston
Westborough, MA
Tel: 774-760-0087
Fax: 774-760-0088

Chicago
Itasca, IL
Tel: 630-285-0071
Fax: 630-285-0075

Cleveland
Independence, OH
Tel: 216-447-0464
Fax: 216-447-0643

Dallas
Addison, TX
Tel: 972-818-7423
Fax: 972-818-2924

Detroit
Novi, MI
Tel: 248-848-4000

Houston, TX
Tel: 281-894-5983

Indianapolis
Noblesville, IN
Tel: 317-773-8323
Fax: 317-773-5453

Los Angeles
Mission Viejo, CA
Tel: 949-462-9523
Fax: 949-462-9608

New York, NY
Tel: 631-435-6000

San Jose, CA
Tel: 408-735-9110

Canada - Toronto
Tel: 905-673-0699
Fax: 905-673-6509

ASIA/PACIFIC

Asia Pacific Office
Suites 3707-14, 37th Floor
Tower 6, The Gateway
Harbour City, Kowloon

Hong Kong
Tel: 852-2943-5100
Fax: 852-2401-3431

Australia - Sydney
Tel: 61-2-9868-6733
Fax: 61-2-9868-6755

China - Beijing
Tel: 86-10-8569-7000
Fax: 86-10-8528-2104

China - Chengdu
Tel: 86-28-8665-5511
Fax: 86-28-8665-7889

China - Chongqing
Tel: 86-23-8980-9588
Fax: 86-23-8980-9500

China - Dongguan
Tel: 86-769-8702-9880

China - Hangzhou
Tel: 86-571-8792-8115
Fax: 86-571-8792-8116

China - Hong Kong SAR
Tel: 852-2943-5100
Fax: 852-2401-3431

China - Nanjing
Tel: 86-25-8473-2460
Fax: 86-25-8473-2470

China - Qingdao
Tel: 86-532-8502-7355
Fax: 86-532-8502-7205

China - Shanghai
Tel: 86-21-5407-5533
Fax: 86-21-5407-5066

China - Shenyang
Tel: 86-24-2334-2829
Fax: 86-24-2334-2393

China - Shenzhen
Tel: 86-755-8864-2200
Fax: 86-755-8203-1760

China - Wuhan
Tel: 86-27-5980-5300
Fax: 86-27-5980-5118

China - Xian
Tel: 86-29-8833-7252
Fax: 86-29-8833-7256

ASIA/PACIFIC

China - Xiamen
Tel: 86-592-2388138
Fax: 86-592-2388130

China - Zhuhai
Tel: 86-756-3210040
Fax: 86-756-3210049

India - Bangalore
Tel: 91-80-3090-4444
Fax: 91-80-3090-4123

India - New Delhi
Tel: 91-11-4160-8631
Fax: 91-11-4160-8632

India - Pune
Tel: 91-20-3019-1500

Japan - Osaka
Tel: 81-6-6152-7160
Fax: 81-6-6152-9310

Japan - Tokyo
Tel: 81-3-6880-3770
Fax: 81-3-6880-3771

Korea - Daegu
Tel: 82-53-744-4301
Fax: 82-53-744-4302

Korea - Seoul
Tel: 82-2-554-7200
Fax: 82-2-558-5932 or
82-2-558-5934

Malaysia - Kuala Lumpur
Tel: 60-3-6201-9857
Fax: 60-3-6201-9859

Malaysia - Penang
Tel: 60-4-227-8870
Fax: 60-4-227-4068

Philippines - Manila
Tel: 63-2-634-9065
Fax: 63-2-634-9069

Singapore
Tel: 65-6334-8870
Fax: 65-6334-8850

Taiwan - Hsin Chu
Tel: 886-3-5778-366
Fax: 886-3-5770-955

Taiwan - Kaohsiung
Tel: 886-7-213-7828

Taiwan - Taipei
Tel: 886-2-2508-8600
Fax: 886-2-2508-0102

Thailand - Bangkok
Tel: 66-2-694-1351
Fax: 66-2-694-1350

EUROPE

Austria - Wels
Tel: 43-7242-2244-39
Fax: 43-7242-2244-393

Denmark - Copenhagen
Tel: 45-4450-2828
Fax: 45-4485-2829

France - Paris
Tel: 33-1-69-53-63-20
Fax: 33-1-69-30-90-79

Germany - Dusseldorf
Tel: 49-2129-3766400

Germany - Karlsruhe
Tel: 49-721-625370

Germany - Munich
Tel: 49-89-627-144-0
Fax: 49-89-627-144-44

Italy - Milan
Tel: 39-0331-742611
Fax: 39-0331-466781

Italy - Venice
Tel: 39-049-7625286

Netherlands - Drunen
Tel: 31-416-690399
Fax: 31-416-690340

Poland - Warsaw
Tel: 48-22-3325737

Spain - Madrid
Tel: 34-91-708-08-90
Fax: 34-91-708-08-91

Sweden - Stockholm
Tel: 46-8-5090-4654

UK - Wokingham
Tel: 44-118-921-5800
Fax: 44-118-921-5820

07/14/15