

THESE DRAWINGS ARE THE PROPERTY OF QUALTEK ELECTRONICS AND NOT TO BE REPRODUCED FOR OR COMMUNICATED TO A THIRD PARTY WITHOUT THE EXPRESS WRITTEN PERMISSION OF AN OFFICER OF QUALTEK ELECTRONICS.

REVISION			
REV.	DESCRIPTION	DATE	APPROVED

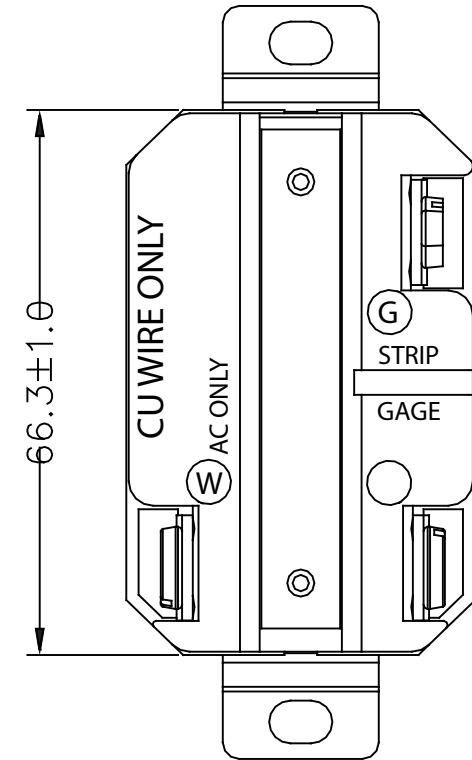
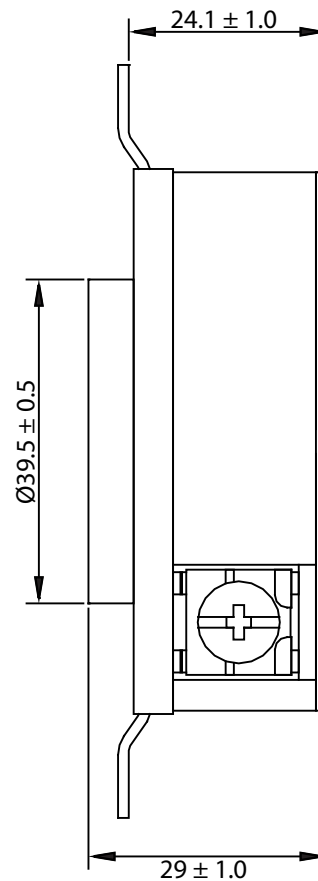
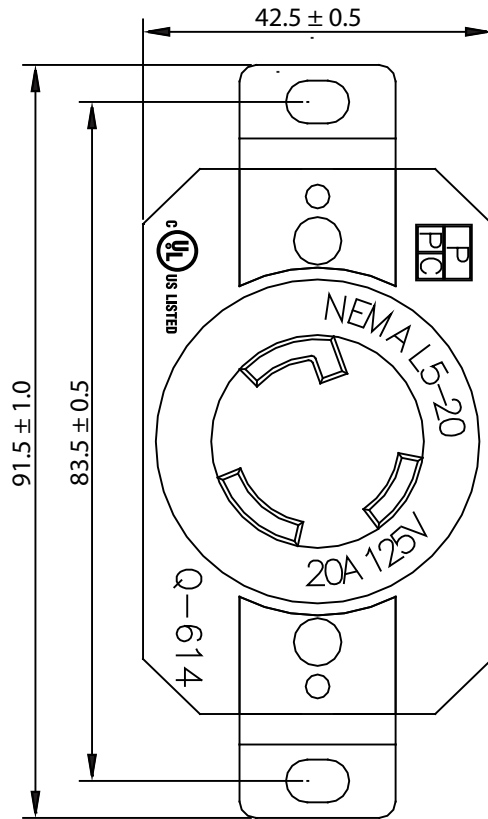

CONTROLLED

NOTES:

1. RATING: 20A 125VAC
2. COLOR: BLACK
3. ACCEPTS #10-#14 AWG COPPER WIRE
4. APPROVALS: UL/cUL LISTED
5. ROHS COMPLIANT

Dim range (mm)		Tolerance +/- (mm)	Qualtek Electronics Corp. PPC DIVISION		
0-1		0.15	Part Number: Q-614		
1-6		0.20	Description: NEMA L5-20R TWIST-LOCK RECEPTACLE		
6-18		0.30	UNIT: mm		
18-50		0.50	Drawn / Date	Checked / Date	Approved / Date
50-120		0.70	R.Nuti	08-25-09	LY / 08-25-09
120-250		0.90			
250-500		1.20			