

10 9 8 7 6 5 4 3 2 1

F

E

D

C

B

A

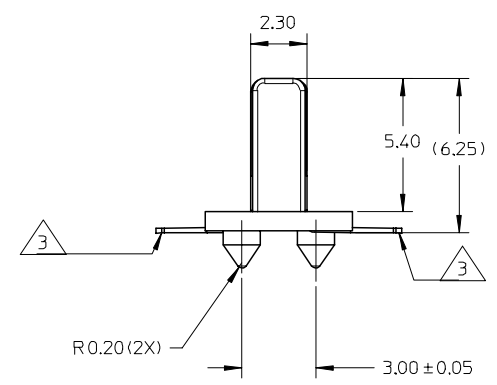
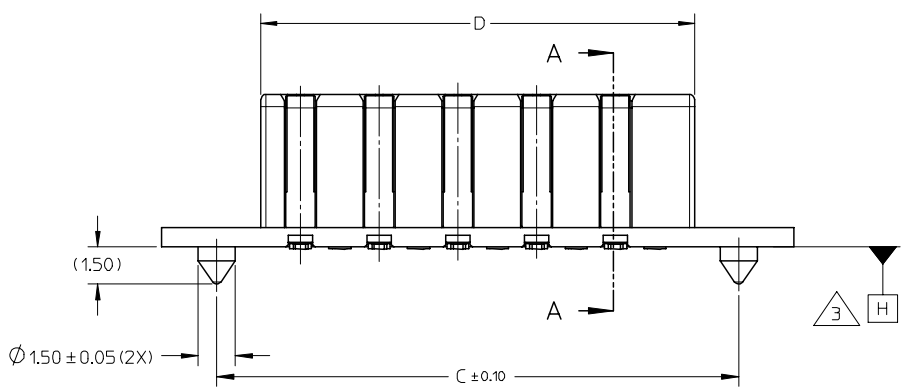
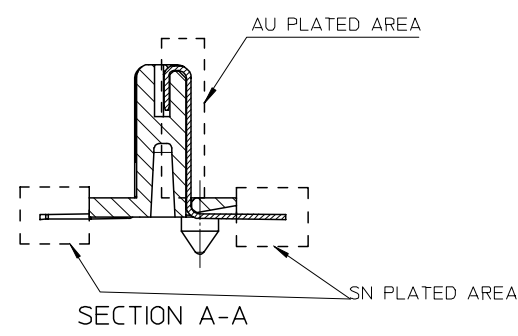
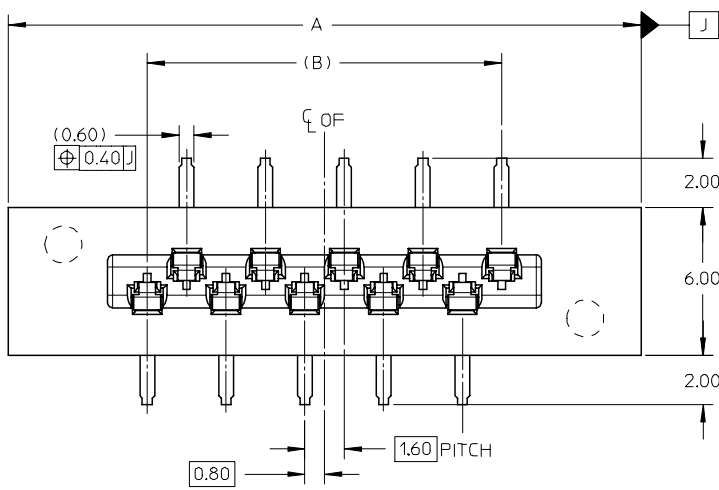

ADD OPTION	EC NO: S2007-0034	2006/07/26
DRWN: CWLAM	CHKD: PATEY	2006/07/26
APPR: PATEY		2006/08/11
REV	DESCRIPTION	
B3		

QUALITY SYMBOLS	▽=0
	∇=0

GENERAL TOLERANCES (UNLESS SPECIFIED)	
	mm INCH
4 PLACES	± --- ± ---
3 PLACES	± --- ± ---
2 PLACES	± 0.20 ± ---
1 PLACE	± 0.25 ± ---
ANGULAR ± 1 °	
DRAFT WHERE APPLICABLE MUST REMAIN WITHIN DIMENSIONS	

DIMENSION STYLE		SCALE	DESIGN UNITS	THIRD ANGLE PROJECTION
MM ONLY		NTS	METRIC	
DRAWN BY	DATE	TITLE		
ARUN	2004/01/14	1.6 PANEL DETACHABLE TYPE PLUG CONNECTOR		
CHECKED BY	DATE			
PTL IM	2004/03/26			
APPROVED BY	DATE	MOLEX INCORPORATED		
SCLOW	2004/03/31	DOCUMENT NO.		SHEET NO.
MATERIAL NO.		SD-87869-001		1 OF 3
SIZE	THIS DRAWING CONTAINS INFORMATION THAT IS PROPRIETARY TO MOLEX INCORPORATED AND SHOULD NOT BE USED WITHOUT WRITTEN PERMISSION			
A3				

9 8 7 6 5 4 3 2 1

	10	9	8	7	6	5	4	3	2	1			
F	PART NUMBER	DIM 'A'	DIM 'B'	DIM 'C'	DIM 'D'	W	F	B0	S0	A0	K0	NUMBER OF CONTACTS	T&R QUANTITY (PCS/REEL)
	87869-1000	25.7	14.4	21.2	17.6	44.0	20.2	26.1	40.4	11.0	8.2	10	600
	87869-1400	32.1	20.8	27.6	24.0	44.0	20.2	32.5	40.4	11.0	8.2	14	600
	87869-1600	35.3	24.0	30.8	27.2	56.0	26.2	35.7	52.4	11.0	8.2	16	600

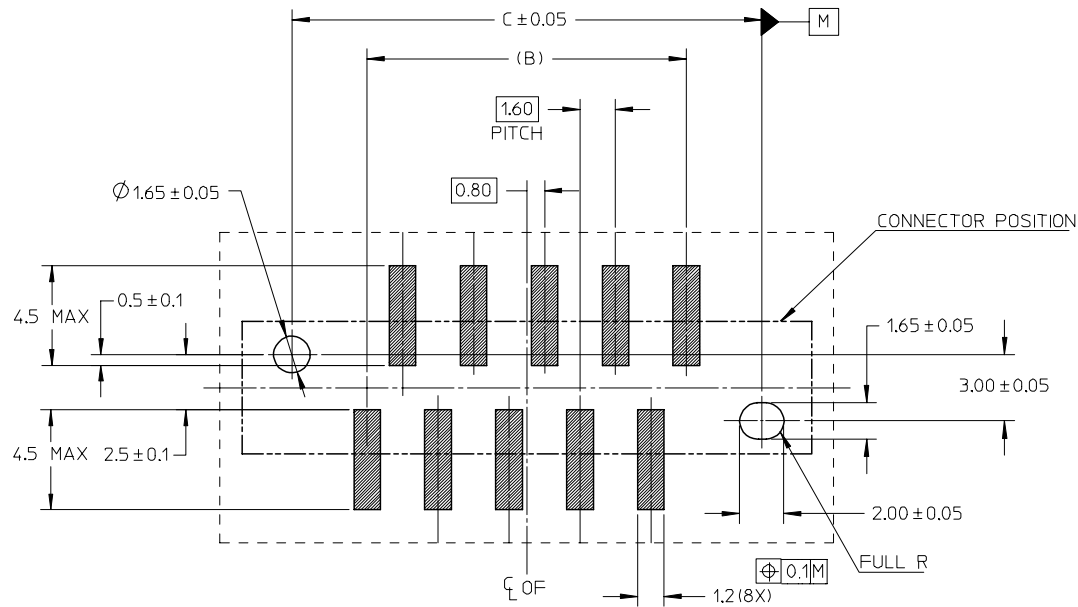

NOTES:

- MATE WITH 87868.
- MATERIAL:
HOUSING : GLASS FILLED NYLON,UL94V-0
TERMINALS : COPPER ALLOY
- MISALIGNMENT OF SOLDER TAILS(TIP) FROM \square :
UPPER DIRECTION : 0.05MM MAX
LOWER DIRECTION : 0.15MM MAX
OFFSET BETWEEN UPPER AND LOWER : 0.15MM MAX.
- RECOMMENDED METAL MASK THICKNESS : 0.18~0.25MM.
- PLATING :
GOLD ON CONTACT AREA : 0.5 μ m MINIMUM
TIN ON SOLDER TAIL AREA : 2 μ m MINIMUM
OVERALL NICKEL UNDERPLATE : 1.5 μ m MINIMUM
- REFER TO PRODUCT SPEC PS-87868-004 FOR PERFORMANCE SPECIFICATIONS.
- PRODUCT IS PACKED IN TAPE AND REEL.
- CONTACT MOLEX FOR AVAILABILITY OF PRODUCT OPTIONS.

P.C.BOARD PATTERN LAYOUT (REFERENCE)
THICKNESS 1.6MM

ADD OPTION EC NO: S2007-0034 DRWN: CWLAM CHKD: PATEY APPR: PATEY 2006/07/26 2006/07/26 2006/08/11	QUALITY SYMBOLS $\nabla = 0$ $\nabla \square = 0$	GENERAL TOLERANCES (UNLESS SPECIFIED)		DIMENSION STYLE MM ONLY		SCALE NTS	DESIGN UNITS METRIC	THIRD ANGLE PROJECTION		
			mm	INCH	DRAWN BY ARUN	DATE 2004/01/14	TITLE 1.6 PANEL DETACHABLE TYPE PLUG CONNECTOR			
		4 PLACES	± ---	± ---	CHECKED BY PTL IM	DATE 2004/03/26				
		3 PLACES	± ---	± ---	APPROVED BY SCLW	DATE 2004/03/31	MOLEX INCORPORATED			
2 PLACES	± 0.20	± ---	MATERIAL NO. SEE TABLE		DOCUMENT NO. SD-87869-001	SHEET NO. 2 OF 3				
1 PLACE	± 0.25	± ---	DRAFT WHERE APPLICABLE MUST REMAIN WITHIN DIMENSIONS		THIS DRAWING CONTAINS INFORMATION THAT IS PROPRIETARY TO MOLEX INCORPORATED AND SHOULD NOT BE USED WITHOUT WRITTEN PERMISSION					
ANGULAR ± 1 °										

TAPE & REEL DETAIL

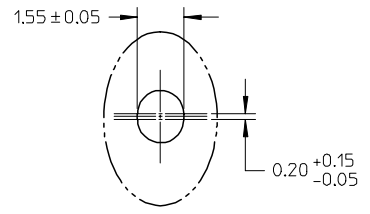
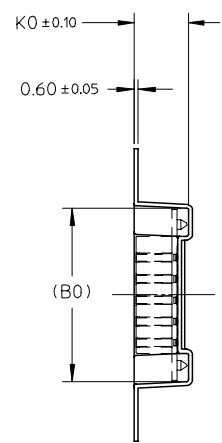
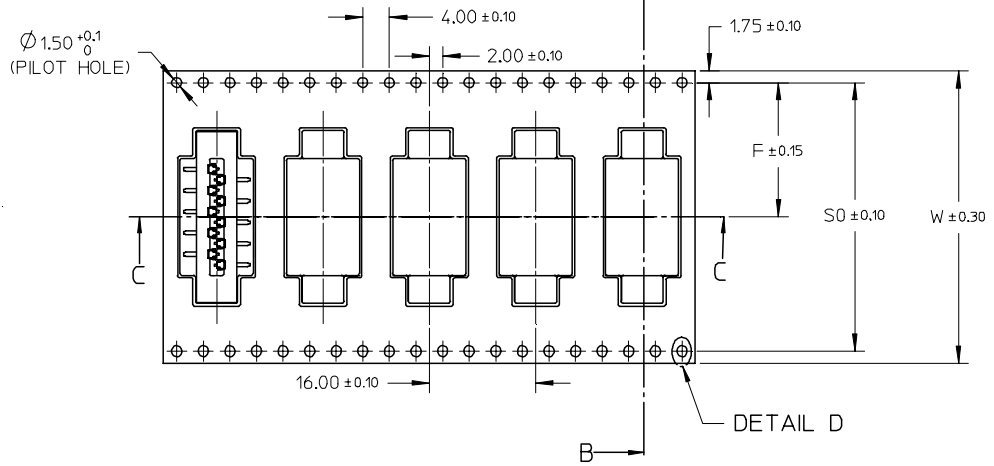

DETAIL D

SECTION B-B

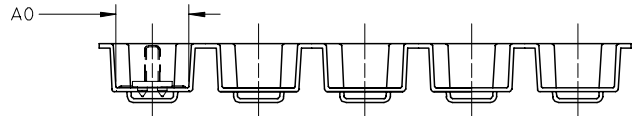

SECTION C-C

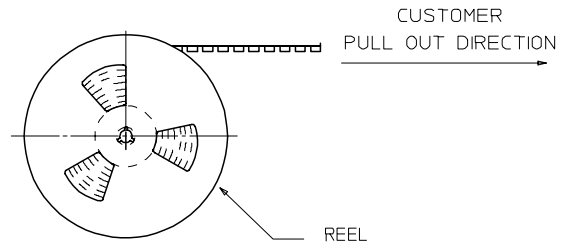

TAPE AND REEL ORIENTATION

NOTES:

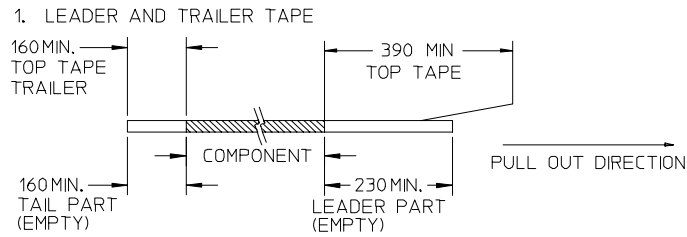

2. PEELING OFF FORCE OF THE TOP TAPE: 20-80gf.
(PEELING DIRECTION AS SHOWN IN FOLLOWING FIGURE)

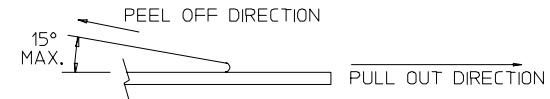

3. PACKAGING STANDARD IS AS PER EIA-481.
4. TAPE & REEL QUANTITY = REFER TO TABLE

ADD OPTION	EC NO: S2007-0034	2006/07/26	2006/08/11
DRWN: CWLAM	2006/07/26		
CHKD: PATEY			
APPR: PATEY			
REV	DESCRIPTION		
B3			

QUALITY SYMBOLS	▽=0
	∇=0

GENERAL TOLERANCES (UNLESS SPECIFIED)	
	MM ONLY
4 PLACES	± ---
3 PLACES	± ---
2 PLACES	± 0.20
1 PLACE	± 0.25
ANGULAR ± 1 °	
DRAFT WHERE APPLICABLE MUST REMAIN WITHIN DIMENSIONS	

DIMENSION STYLE	
MM ONLY	
DRAWN BY	DATE
ARUN	2004/01/14
CHECKED BY	DATE
PTL IM	2004/03/26
APPROVED BY	DATE
SCLOW	2004/03/31
MATERIAL NO.	
SEE TABLE	
SIZE	A3

SCALE	DESIGN UNITS	THIRD ANGLE PROJECTION
NTS	METRIC	☉ □
TITLE		
1.6 PANEL DETACHABLE TYPE PLUG CONNECTOR		
MOLEX INCORPORATED		
DOCUMENT NO.	SHEET NO.	
SD-87869-001	3 OF 3	
THIS DRAWING CONTAINS INFORMATION THAT IS PROPRIETARY TO MOLEX INCORPORATED AND SHOULD NOT BE USED WITHOUT WRITTEN PERMISSION		