

- △1 COORDINATE DIMENSION APPLIES FROM BASIC LOCATION.
- △2 10 AND 14 POSITION SIZES CONTAIN ONLY ONE SLOT FOR SNAP-IN POLARIZER (MILITARY POLARIZATION) LOCATED AS SHOWN.
- △3 10 POSITION SIZES CONTAIN ONLY ONE SLOT FOR DUAL POLARIZATION, LOCATED AS SHOWN.
- 4. RECOMMENDED PRINTED CIRCUIT BOARD THICKNESS IS 1.57 [.062].
- △5 POSTS:  
GOLD FLASH OVER PALLADIUM-NICKEL PLATE, 0.38µm [.000015] MIN TOTAL ON THE LOCALIZED PLATE AREA,  
2.54µm [.000100] MIN TIN-LEAD PLATE ON THE SOLDER-TAIL,  
1.27µm [.000050] MIN NICKEL UNDERPLATE ON THE ENTIRE POST.  
OR  
0.38µm [.000015] MIN GOLD PLATE ON THE LOCALIZED PLATE AREA,  
2.54µm [.000100] MIN TIN-LEAD PLATE ON THE SOLDER-TAIL,  
1.27µm [.000050] MIN NICKEL UNDERPLATE ON THE ENTIRE POST.
- △6 MATERIAL:  
HOUSING: GLASS FILLED POLYESTER, 94V-0 RATED, BLACK.  
POSTS: PHOSPHOR BRONZE OR BRASS.

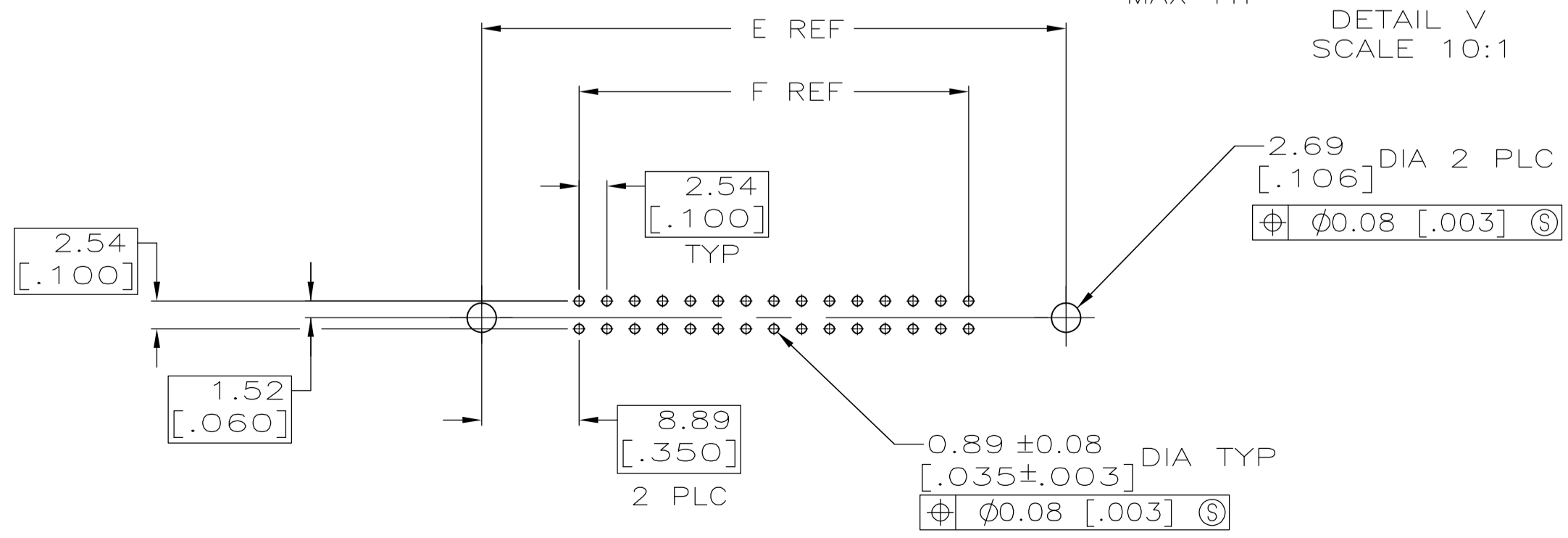
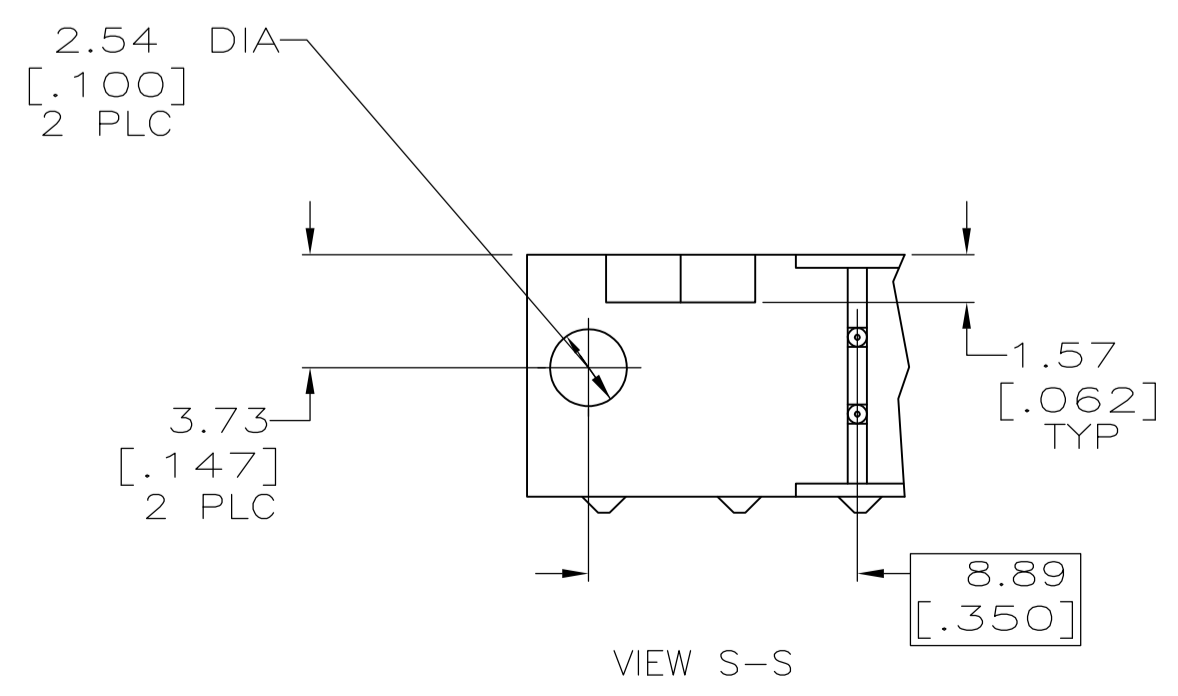
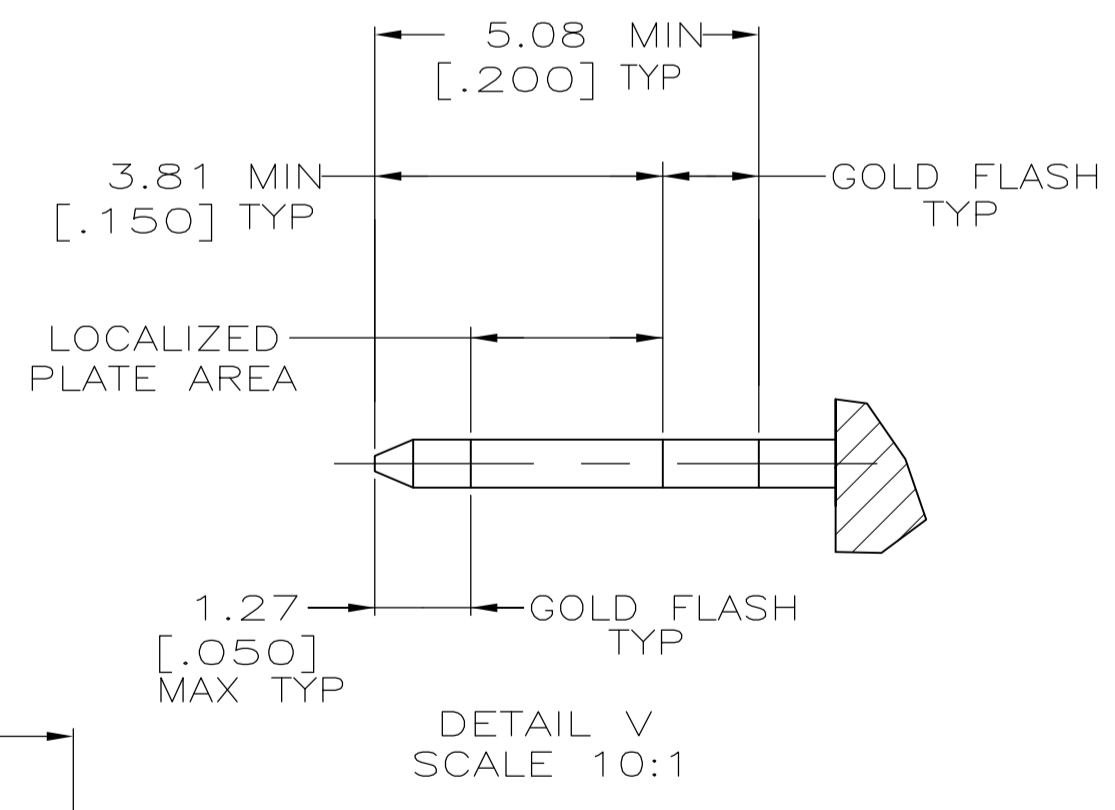
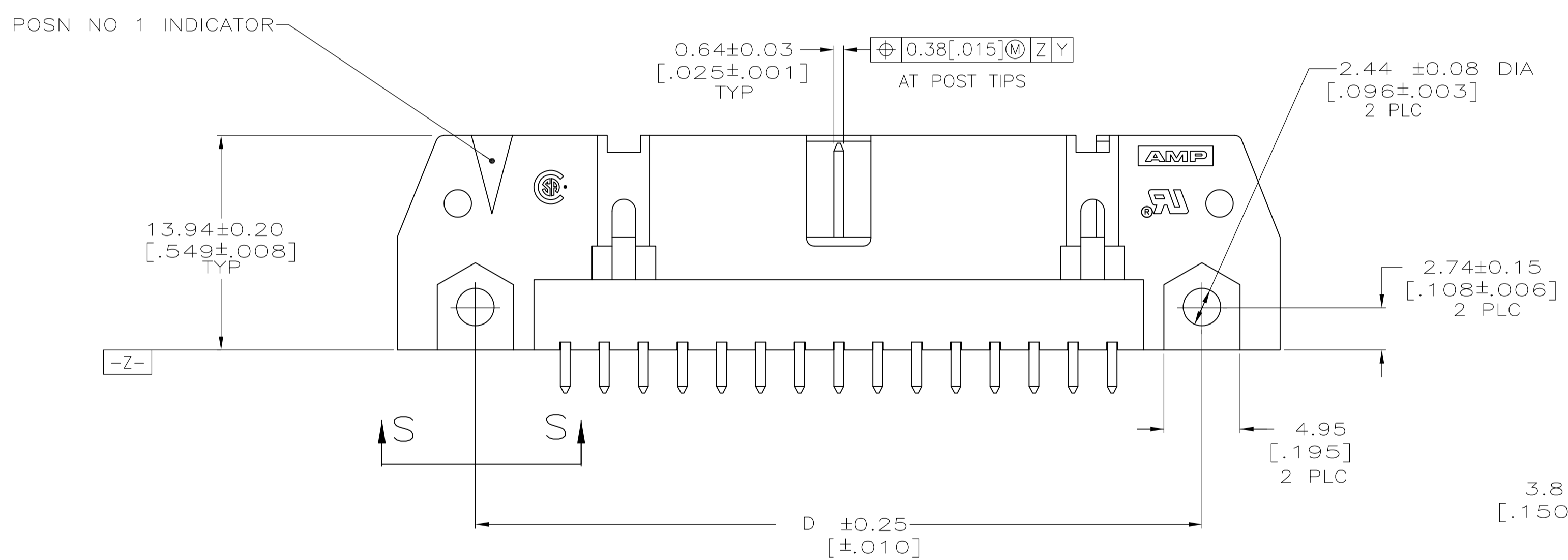

53.34 [2.100]	71.12 [2.800]	65.02 [2.560]	75.18 [2.960]	71.12 [2.800]	60.96 [2.400]	44	1-102153-3
78.74 [3.100]	96.52 [3.800]	90.42 [3.560]	100.58 [3.960]	96.52 [3.800]	86.36 [3.400]	64	1-102153-2
73.66 [2.900]	91.44 [3.600]	85.34 [3.360]	95.50 [3.760]	91.44 [3.600]	81.28 [3.200]	60	1-102153-1
60.96 [2.400]	78.74 [3.100]	72.64 [2.860]	82.80 [3.260]	78.74 [3.100]	68.58 [2.700]	50	1-102153-0
48.26 [1.900]	66.04 [2.600]	59.94 [2.360]	70.10 [2.760]	66.04 [2.600]	55.88 [2.200]	40	102153-9
40.64 [1.600]	58.42 [2.300]	52.32 [2.060]	62.48 [2.460]	58.42 [2.300]	48.26 [1.900]	34	102153-8
35.56 [1.400]	53.34 [2.100]	47.24 [1.860]	57.40 [2.260]	53.34 [2.100]	43.18 [1.700]	30	102153-7
30.48 [1.200]	48.26 [1.900]	42.16 [1.660]	52.32 [2.060]	48.26 [1.900]	38.10 [1.500]	26	102153-6
27.94 [1.100]	45.72 [1.800]	39.62 [1.560]	49.78 [1.960]	45.72 [1.800]	35.56 [1.400]	24	102153-5
22.86 [.900]	40.64 [1.600]	34.54 [1.360]	44.70 [1.760]	40.64 [1.600]	30.48 [1.200]	20	102153-4
17.78 [.700]	35.56 [1.400]	29.46 [1.160]	39.62 [1.560]	35.56 [1.400]	25.40 [1.000]	16	102153-3
15.24 [.600]	33.02 [1.300]	26.92 [1.060]	37.08 [1.460]	33.02 [1.300]	22.86 [.900]	14	102153-2
10.16 [.400]	27.94 [1.100]	21.84 [.860]	32.00 [1.260]	27.94 [1.100]	17.78 [.700]	10	102153-1
F	E	D	C	B	A	NO OF POSN	PART NUMBER

THIS DRAWING IS A CONTROLLED DOCUMENT. DIN 4-23-90 H. MOLL

DIMENSIONS: mm [INCHES]	TOLERANCES UNLESS OTHERWISE SPECIFIED:	APVD	NAME
0 PLC ± .01	1 PLC ± .01		HEADER ASSY, UNIVERSAL, AMP-LATCH
2 PLC ± .015	3 PLC ± .015		108-40018
4 PLC ± .015	ANGLES ± .01		APPLICATION SPEC
MATERIAL	FINISH	WEIGHT	SIZE CASE CODE DRAWING NO
		A1	00779 102153
CUSTOMER DRAWING		SCALE 4:1	SHEET 1 OF 1 REV 1

STE TE Connectivity