

DESIGNED FOR USE WITH	
.141 SR	
CABLE ENTRY DIAMETER MINIMUM	
SLEEVE	.142
CONTACT	.039

REVISIONS			
REV	DESCRIPTION	DATE	APPROVED
B	PER EC 0U20-0692-00	9/24/01	<i>C. Hoang</i> 9/24/01

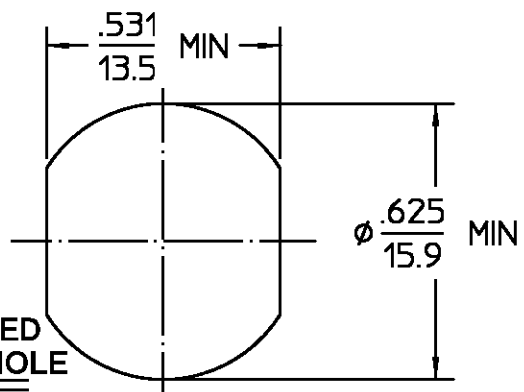

**RECOMMENDED MOUNTING HOLE**

HOUSING MOUNTING NUT LOCKWASHER	STAINLESS STEEL PER ASTM-A484 AND ASTM-A582, TYPE 303	PASSIVATE PER QQ-P-35
CLAMP NUT	STAINLESS STEEL PER ASTM-A484 AND ASTM-A582, TYPE 303	GOLD PLATE PER MIL-G-45204
DIELECTRIC	PTFE FLUOROCARBON PER ASTM-D-1457	N/A
CENTER CONTACT	BRASS PER ASTM-B-16, HALF HARD	GOLD PLATE PER MIL-G-45204
CONTACT EXT.	BERYLLIUM COPPER PER ASTM-B-196 OR ASTM-B-197, ALLOY C17300, CONDITION H	GOLD PLATE PER MIL-G-45204
SLEEVE	BRASS PER ASTM-16, HALF HARD	GOLD PLATE PER MIL-G-45204
RETAINING RING	BERYLLIUM COPPER PER ASTM-B-194, ALLOY C17200, CONDITION H	GOLD PLATE PER MIL-G-45204
GASKET	SILICONE RUBBER PER ZZ-R-765	N/A
<b>COMPONENT</b>	<b>MATERIAL</b>	<b>FINISH</b>

ELECTRICAL	MECHANICAL	ENVIRONMENTAL
Nominal Impedance (Ohms) <u>50</u>	Interface Dimensions MIL-STD-348A, Fig. <u>304-2</u>	Temperature Rating <u>-65 TO +165°C</u>
Frequency Range (GHz) DC to <u>11.0</u>	Recommended Mating Torque <u>6-10 IN-LBS</u>	Vibration MIL-STD-202, Method 204, Condition B
Volt Rating (VRMS MAX) @ Sea Level <u>1,000</u>	Mating Characteristics: Insertion (MAX Lbs) <u>2.0</u>	Shock MIL-STD-202, Method 213, Condition I
VSWR <u>1.06 + .007f(GHz)</u>	Withdrawal (MIN Oz) <u>2.0</u>	Thermal Shock MIL-STD-202, Method 107, Condition B, Except High Temp +85 °C
Insertion Loss (dB MAX) <u>.05√f(GHz)</u>	Force to Engage and Disengage (In-Lbs MAX) <u>6.0</u>	Moisture Resistance MIL-STD-202, Method 106
RF Leakage (dB MIN) <u>-[95-f(GHz)]</u>	Center Contact Captivation: Axial (Lbs) <u>N/A</u>	Corrosion - MIL-STD-202, Method 101, Condition B, 5% salt spray
Corona, 70,000 Ft (VRMS MIN) <u>500</u>	Radial (In-Oz) <u>N/A</u>	
Dielectric Withstanding Voltage (VRMS MIN) @ Sea Level <u>2,500</u>	Cable Retention: Axial Force (Lbs) <u>60.0</u>	
Contact Resistance (Milliohms MAX): Center Contact <u>1.0</u>	Torque (In-Oz) <u>N/A</u>	
Outer Contact <u>2.0</u>	Weight (Grams) <u>TBD</u>	
Cable to Housing <u>N/A</u>		
RF High Potential @ Sea Level (VRMS MIN @ 5 MHz) <u>1,500</u>		
LR.(Megohms MIN) <u>10,000</u>		

.XXX = in  
XX.X = mm (REF)

UNLESS OTHERWISE SPECIFIED DIMENSIONS ARE IN INCHES

FRAC.	DEC.	ANGLES
± 1/64	±.005	± 1°

These drawings and specifications are the property of M/A COM Interconnect Div. and shall not be reproduced or copied or used in whole or in part as the basis for the manufacture or sale of item(s) without written permission.

DRAWN BY	DATE
PRB	8-7-67
CHECKED BY	
AJA	8-10-67
APPD BY	
D NANIA	8-14-67

USE ASS'Y PROCEDURE

408-04903  
NO. AP. (30-011)

**AMP Incorporated**  
140 Fourth Avenue  
Waltham, MA 02451-7599

**AMP**

TITLE **'OSN' STRAIGHT BULKHEAD FEEDTHRU CABLE JACK DIRECT SOLDER ATTACHMENT**

SIZE	CODE IDENT NO.	REV
B	26805	05 <sub>2</sub>

3004-7841-00

SCALE 2.5:1 SHEET 1 OF 1

CUSTOMER DRAWING

AMP PART # 1057154-1  
SHEET 1 OF 1 REV B