

THIS DRAWING IS UNPUBLISHED. RELEASED FOR PUBLICATION .19
 BY AMP INCORPORATED. ALL RIGHTS RESERVED.

LOC	DIST	REVISIONS			
P	LTR	DESCRIPTION	DATE	DWN	APVD
AD	25	C	REDRAWN PER EC 001B-0034-00	23 MAR 00	-

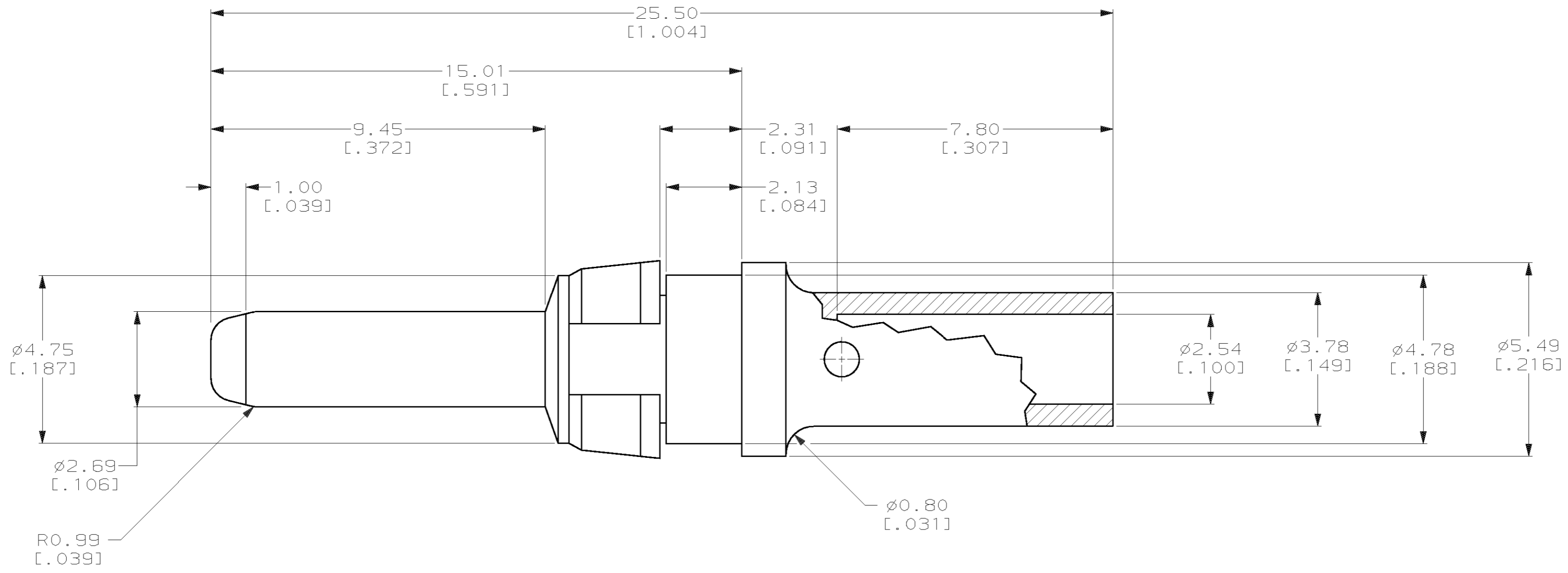

- 1 CONTACT: BRASS.
RETAINING RING: BERYLLIUM COPPER.
- 2 CONTACT: 0.76µm[.000030] MIN GOLD
OVER 1.27µm[.000050] MIN NICKEL.
- 3. WIRE BARREL WILL ACCEPT 12-14 AWG WIRE.
- 4. MATES WITH 148250-1.
- 5. RECOMMENDED CRIMPING TOOL: DANIELS TOOL
#M300-BT, POSITIONER PART NUMBER SP689,
SETTING #1, STRIP LENGTH 8.13[.320].

148249-1
PART NUMBER

THIS DRAWING IS A CONTROLLED DOCUMENT.		DWN B. CARBO 23 MAR 00	AMP Incorporated Harrisburg, PA 17105-3608	
DIMENSIONS: mm [INCHES]		CHK C. RICHARD 23 MAR 00	NAME C. RICHARD	
TOLERANCES UNLESS OTHERWISE SPECIFIED:		APVD C. RICHARD 23 MAR 00	PRODUCT SPEC -	
0 PLC ±-		APPLICATION SPEC -		
1 PLC ±-		SIZE A2		
2 PLC ±0.13 [.005]		CAGE CODE 00779		
3 PLC ±-		DRAWING NO C- 148249		
4 PLC ±-		RESTRICTED TO -		
ANGLES ±-		WEIGHT -		
FINISH		SCALE 10:1		
MATERIAL		SHEET 1 OF 1		
		REV C		
		CUSTOMER DRAWING		

148249