

Model 532

Clipped Sine Wave TCXO/VC-TCXO



Part Dimensions:
5.0 × 3.2 × 1.65mm • 60.7734mg

Features

- Ceramic Surface Mount Package
- Low Phase Jitter Performance
- Fundamental Crystal Design
- Frequency Range 13 – 52MHz *
- +1.8V, +2.5V, +2.8V, +3.0V and +3.3V Operation
- Voltage Control Option for Frequency Tuning [VC-TCXO]
- Tape and Reel Packaging, EIA-481

Standard Frequencies

* See Page 7 for common frequencies.
Check with factory for frequency availability.

Applications

- GPS
- IoT and IIoT
- Wireless Connectivity
- Synchronous Ethernet
- Base Stations/Femto Cells
- Mobile Communication
- WiMax/Wi-Fi/WLAN
- Phase Locked Loop
- Test Equipment

Description

CTS Model 532 is a low cost, small size, high performance Temperature Compensated Crystal Oscillator [TCXO]. Employing analog IC technology that provides a clipped sine wave output, high-order temperature compensation engine; coupled with a fundamental quartz crystal M532 has excellent stability and low jitter/phase noise performance.

Ordering Information

Model	Supply Voltage	Frequency Code [MHz]	Frequency Stability ²	Temperature Range	Frequency Tuning	Packaging																														
532	L	XXX	10	D	T	T																														
	<table border="1"> <thead> <tr> <th>Code</th> <th>Voltage</th> </tr> </thead> <tbody> <tr> <td>M</td> <td>+1.8Vdc</td> </tr> <tr> <td>N</td> <td>+2.5Vdc</td> </tr> <tr> <td>T</td> <td>+2.8Vdc</td> </tr> <tr> <td>R</td> <td>+3.0Vdc</td> </tr> <tr> <td>L</td> <td>+3.3Vdc</td> </tr> </tbody> </table>	Code	Voltage	M	+1.8Vdc	N	+2.5Vdc	T	+2.8Vdc	R	+3.0Vdc	L	+3.3Vdc		<table border="1"> <thead> <tr> <th>Code</th> <th>Stability</th> </tr> </thead> <tbody> <tr> <td>05</td> <td>±0.5ppm [GPS]</td> </tr> <tr> <td>10</td> <td>±1.0ppm</td> </tr> <tr> <td>15</td> <td>±1.5ppm</td> </tr> <tr> <td>20</td> <td>±2.0ppm</td> </tr> <tr> <td>25</td> <td>±2.5ppm</td> </tr> </tbody> </table>	Code	Stability	05	±0.5ppm [GPS]	10	±1.0ppm	15	±1.5ppm	20	±2.0ppm	25	±2.5ppm		<table border="1"> <thead> <tr> <th>Code</th> <th>Frequency Deviation</th> </tr> </thead> <tbody> <tr> <td>T</td> <td>TCXO [No Voltage Control]</td> </tr> <tr> <td>A</td> <td>±5ppm Minimum ³</td> </tr> </tbody> </table>	Code	Frequency Deviation	T	TCXO [No Voltage Control]	A	±5ppm Minimum ³	
Code	Voltage																																			
M	+1.8Vdc																																			
N	+2.5Vdc																																			
T	+2.8Vdc																																			
R	+3.0Vdc																																			
L	+3.3Vdc																																			
Code	Stability																																			
05	±0.5ppm [GPS]																																			
10	±1.0ppm																																			
15	±1.5ppm																																			
20	±2.0ppm																																			
25	±2.5ppm																																			
Code	Frequency Deviation																																			
T	TCXO [No Voltage Control]																																			
A	±5ppm Minimum ³																																			
	<table border="1"> <thead> <tr> <th>Code</th> <th>Frequency</th> </tr> </thead> <tbody> <tr> <td colspan="2">Product Frequency Code ¹</td> </tr> </tbody> </table>	Code	Frequency	Product Frequency Code ¹			<table border="1"> <thead> <tr> <th>Code</th> <th>Temp. Range</th> </tr> </thead> <tbody> <tr> <td>C</td> <td>-20°C to +70°C</td> </tr> <tr> <td>D</td> <td>-30°C to +85°C</td> </tr> <tr> <td>I</td> <td>-40°C to +85°C</td> </tr> </tbody> </table>	Code	Temp. Range	C	-20°C to +70°C	D	-30°C to +85°C	I	-40°C to +85°C	<table border="1"> <thead> <tr> <th>Code</th> <th>Packing</th> </tr> </thead> <tbody> <tr> <td>T</td> <td>1k pcs./reel</td> </tr> </tbody> </table>	Code	Packing	T	1k pcs./reel																
Code	Frequency																																			
Product Frequency Code ¹																																				
Code	Temp. Range																																			
C	-20°C to +70°C																																			
D	-30°C to +85°C																																			
I	-40°C to +85°C																																			
Code	Packing																																			
T	1k pcs./reel																																			

Notes:

- 1] Refer to document 016-1454-0, Frequency Code Tables. 3-digits for frequencies <100MHz, 4-digits for frequencies 100MHz or greater.
- 2] Frequency vs. Temperature only.
- 3] See Electrical Characteristics for Voltage Control range per Supply Voltage selected.

**Not all performance combinations and frequencies may be available.
Contact your local CTS Representative or CTS Customer Service for availability.**

This product is specified for use only in standard commercial applications. Supplier disclaims all express and implied warranties and liability in connection with any use of this product in any non-commercial applications or in any application that may expose the product to conditions that are outside of the tolerances provided in its specification.



Electrical Specifications

Operating Conditions

PARAMETER	SYMBOL	CONDITIONS	MIN	TYP	MAX	UNIT
Maximum Supply Voltage	V_{CC}	-	-0.6	-	4.6	V
Maximum Control Voltage	V_C	-	-0.6	-	$V_{CC}+0.6$	V
Supply Voltage	V_{CC}	$\pm 5\%$	1.71	1.8	1.89	V
			2.38	2.5	2.63	
			2.66	2.8	2.94	
			2.85	3.0	3.15	
			3.14	3.3	3.47	
Supply Current	I_{CC}	13.00MHz - <26.00MHz	-	-	2.0	mA
		26.00MHz - 52.00MHz	-	-	2.5	
Output Load	$R_L//C_L$	-	10k Ohm//10pF			-
Operating Temperature	T_A		-20		+70	°C
			-30	+25	+85	
			-40		+85	
Storage Temperature	T_{STG}	-	-40	-	+85	°C

Frequency Stability

PARAMETER	SYMBOL	CONDITIONS	MIN	TYP	MAX	UNIT
Frequency Range	f_0	-		13 - 52		MHz
Frequency Stability						
Initial Calibration	$\Delta f/f_0$	Calibration @ +25°C, After 2 Reflows	-2.0	-	2.0	ppm
Temperature Only		Referenced to +25°C Reading	0.5, 1.0, 1.5, 2.0, 2.5			\pm ppm
Voltage Coefficient	$\Delta f/f_{25}$	Supply Voltage, $\pm 5\%$	-0.2	-	0.2	ppm
Load Coefficient		Load, $\pm 10\%$	-0.2	-	0.2	ppm
Aging	$\Delta f/f_{25}$	First Year @ +25°C, nominal V_{CC} and V_C	-1.0	-	1.0	ppm
		10 Years @ +25°C, nominal V_{CC} and V_C	-10	-	10	

Output Parameters

PARAMETER	SYMBOL	CONDITIONS	MIN	TYP	MAX	UNIT
Output Type	-	DC Coupled		Clipped Sine		-
Output Voltage Levels	V_O	-	0.8	-	-	V_{P-P}
Start Up Time	T_S	Application of V_{CC}	-	-	2	ms
Phase Noise	-	See Typical Plots	-	-	-	-

Control Voltage

PARAMETER	SYMBOL	CONDITIONS	MIN	TYP	MAX	UNIT
Control Voltage	V_C	1.8V	0.30	0.90	1.50	V
		2.5V, 2.8V, 3.0V, 3.3V	0.40	1.40	2.40	
Frequency Tuning [VCTCXO Only]	$\Delta f/f_0$	Specified V_C Range	± 5	-	-	ppm
Linearity	L	Best Straight Line Fit	-	± 5	± 10	%
Input Impedance	Z_{V_C}	-	500	-	-	kOhms
Transfer Function	-	-		Positive		-

Electrical Specifications

Test Circuit

Clipped Sine

* DC-Cut Capacitor: Add 1000pF capacitor between the TCXO output and input of load.

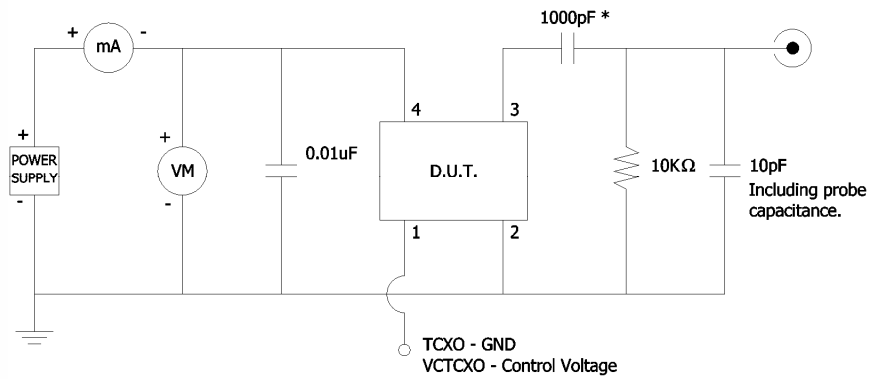

Output Waveform

Clipped Sine

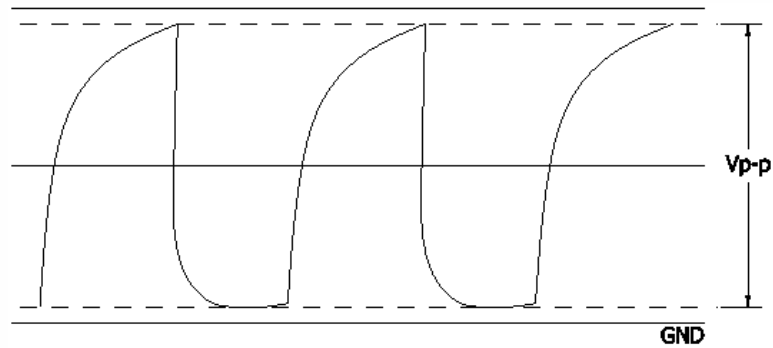

Electrical Specifications

Performance Data

Phase Noise [typical]

12.288MHz, $V_{CC} = +3.3V$, $V_C = +1.4V$, $T_A = +25^\circ C$

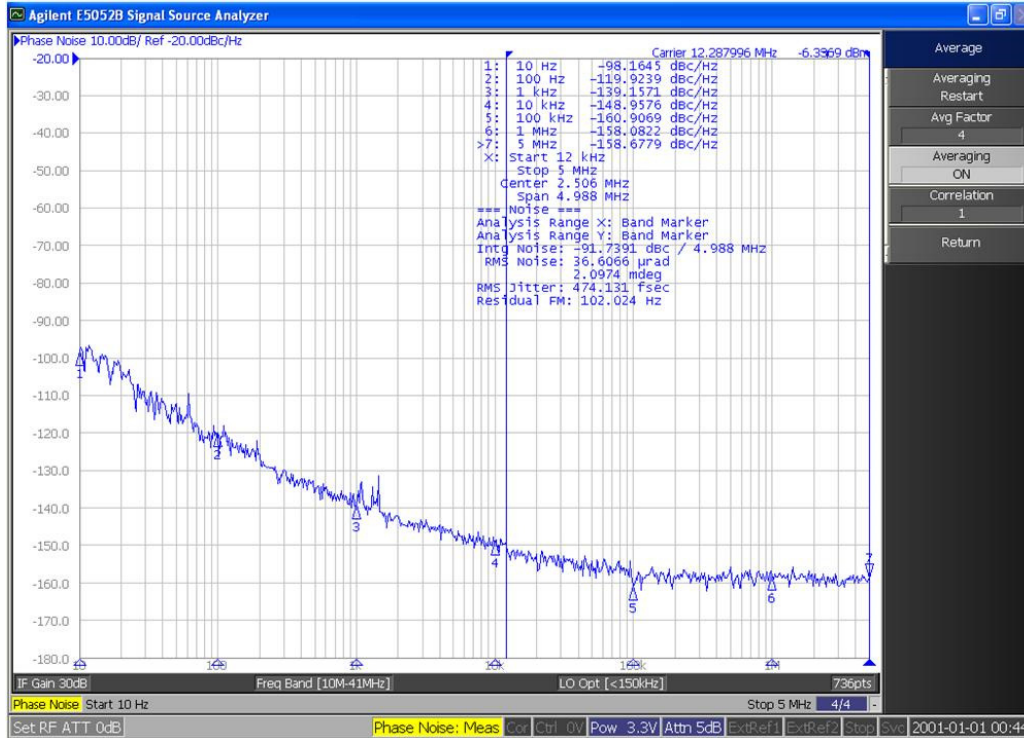

50MHz, $V_{CC} = +3.3V$, $V_C = +1.5V$, $T_A = +25^\circ C$

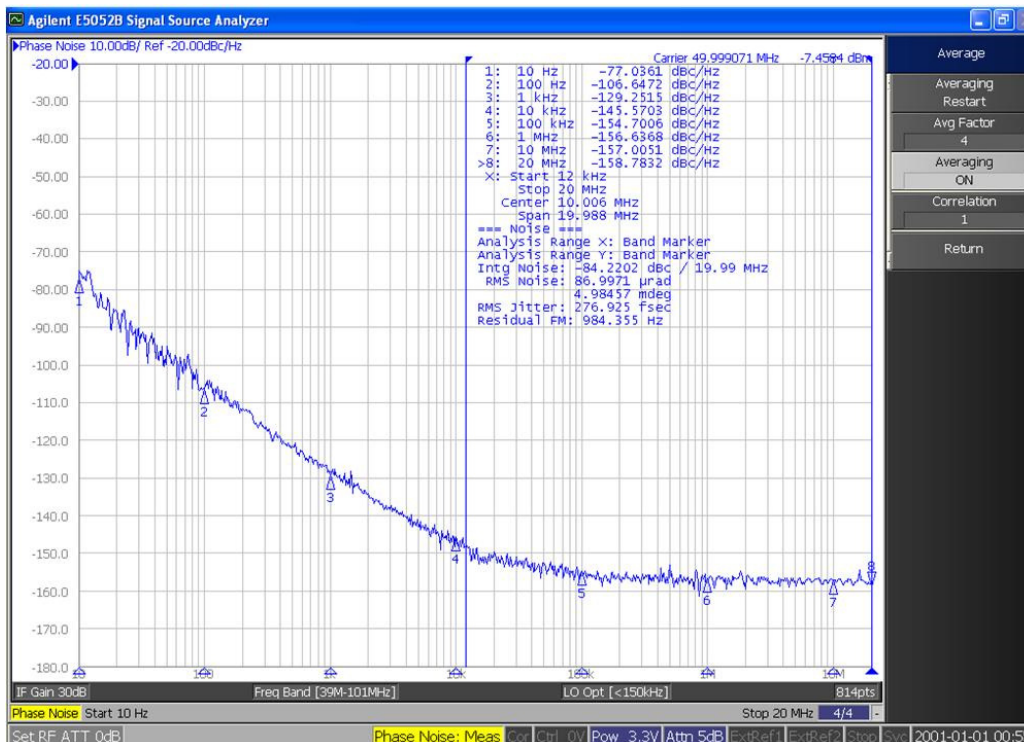

Mechanical Specifications

Package Drawing

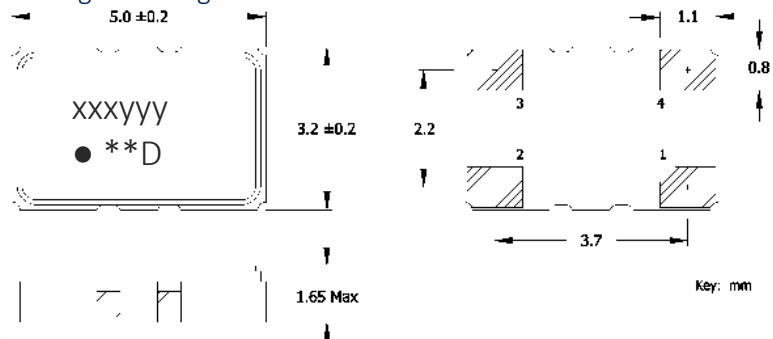

Marking Information

- xxx – Frequency Code.
3-digits for frequencies <100MHz
[See document 016-1454-0, Frequency Code Tables.]
- yyy – Crystal Lot Code or Date Code [Optional].
- – Pin 1 identifier.
- ** – Manufacturing Site Code.
- D – Date Code. See Table I for codes.

Recommended Pad Layout

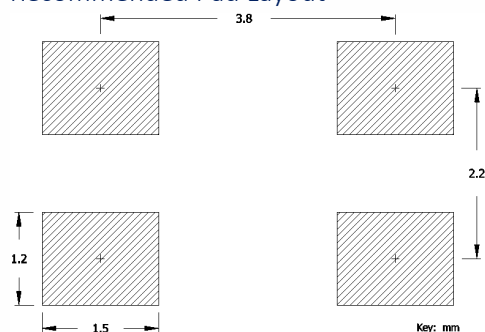

Notes

- JEDEC termination code (e4). Barrier plating is nickel [Ni] with gold [Au] flash plate.
- Reflow conditions per JEDEC J-STD-020; +260°C maximum, 20 seconds.
- MSL = 1.

Pin Assignments

Pin	Symbol	Function
1	GND	Ground [Note 1]
	V _C	Voltage Control [VC-TCXO]
2	GND	Circuit & Package
3	Output	RF Output [Note 2]
4	V _{CC}	Supply Voltage

Notes

- Connect to ground for TCXO, no frequency tuning. This pin can be left floating.
- DC-Cut Capacitor Required. Add 1000pF capacitor between TCXO output and input of load.

Table I - Date Code, Beginning year 2021

					MONTH											
					JAN	FEB	MAR	APR	MAY	JUN	JUL	AUG	SEP	OCT	NOV	DEC
YEAR																
2021	2025	2029	2033	2037	A	B	C	D	E	F	G	H	J	K	L	M
2022	2026	2030	2034	2038	N	P	Q	R	S	T	U	V	W	X	Y	Z
2023	2027	2031	2035	2039	a	b	c	d	e	f	g	h	j	k	l	m
2024	2028	2032	2036	2040	n	p	q	r	s	t	u	v	w	x	y	z

Packaging - Tape and Reel

Tape Drawing

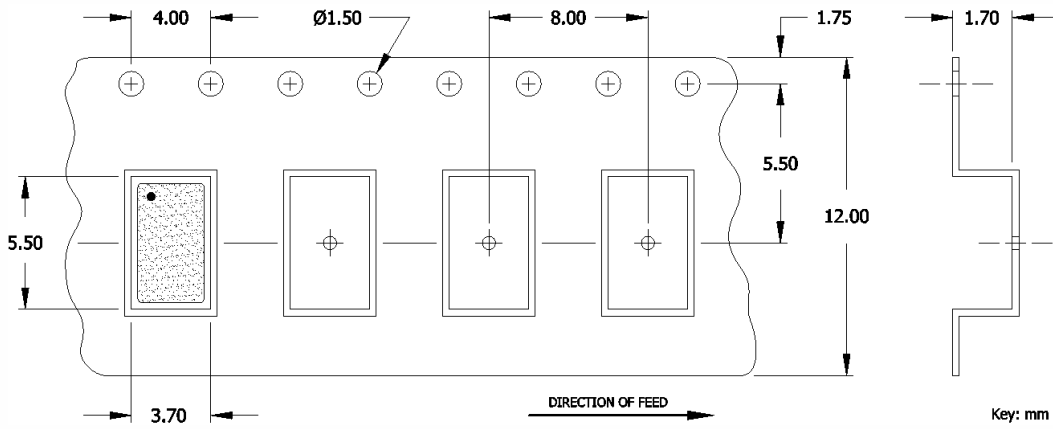

Reel Drawing

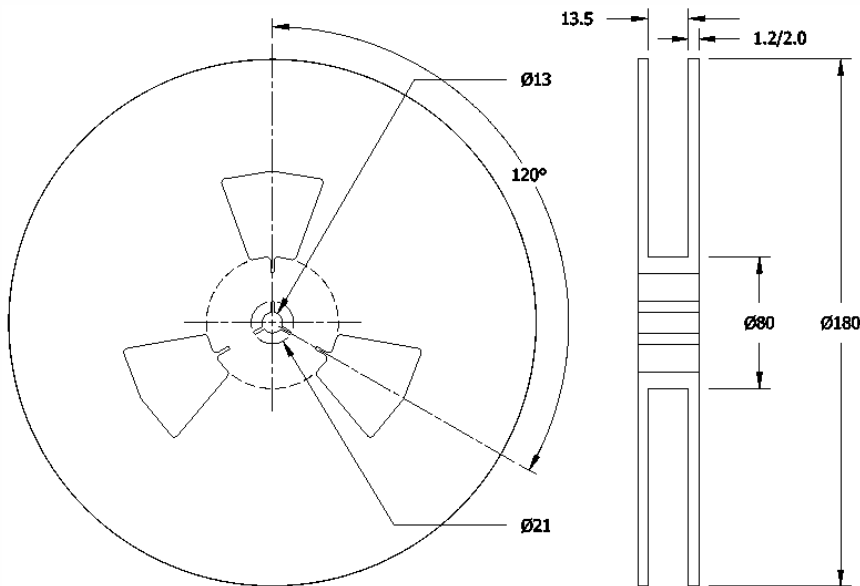

Notes

1. Device quantity is 1k pieces maximum per 180mm reel.
2. Complete CTS part number, frequency value and date code information must appear on reel and carton labels.



Addendum

Common Frequencies – MHz

FREQUENCY	ORDERING CODE	FREQUENCY	ORDERING CODE	FREQUENCY	ORDERING CODE	FREQUENCY	ORDERING CODE
14.400000	144	27.000000	270				
14.745600	147	30.720000	307				
16.000000	160	32.000000	320				
16.384000	163	38.400000	384				
18.432000	184	40.000000	400				
19.200000	192	44.000000	440				
20.000000	200	48.000000	480				
24.000000	240	50.000000	500				
25.000000	250	52.000000	520				
26.000000	260						