

THIS DRAWING IS UNPUBLISHED. RELEASED FOR PUBLICATION  
 © COPYRIGHT - By - ALL RIGHTS RESERVED.

REVISIONS					
P	LTR	DESCRIPTION	DATE	DWN	APVD
	T2	ECO-18-017129	30OCT2018	RZ	RS

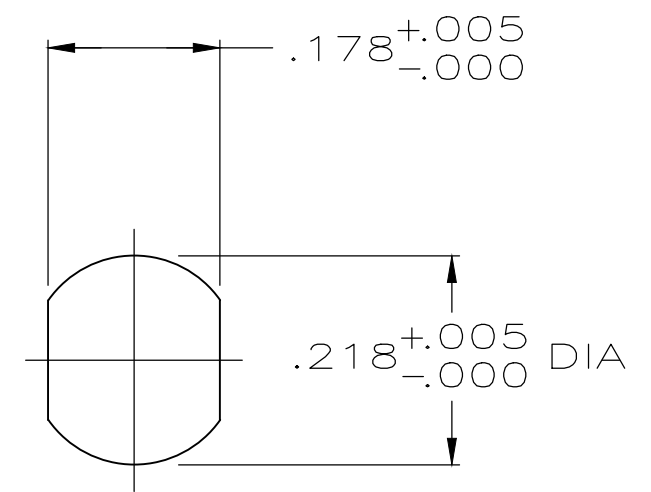

RECOMMENDED PANEL CUTOUT

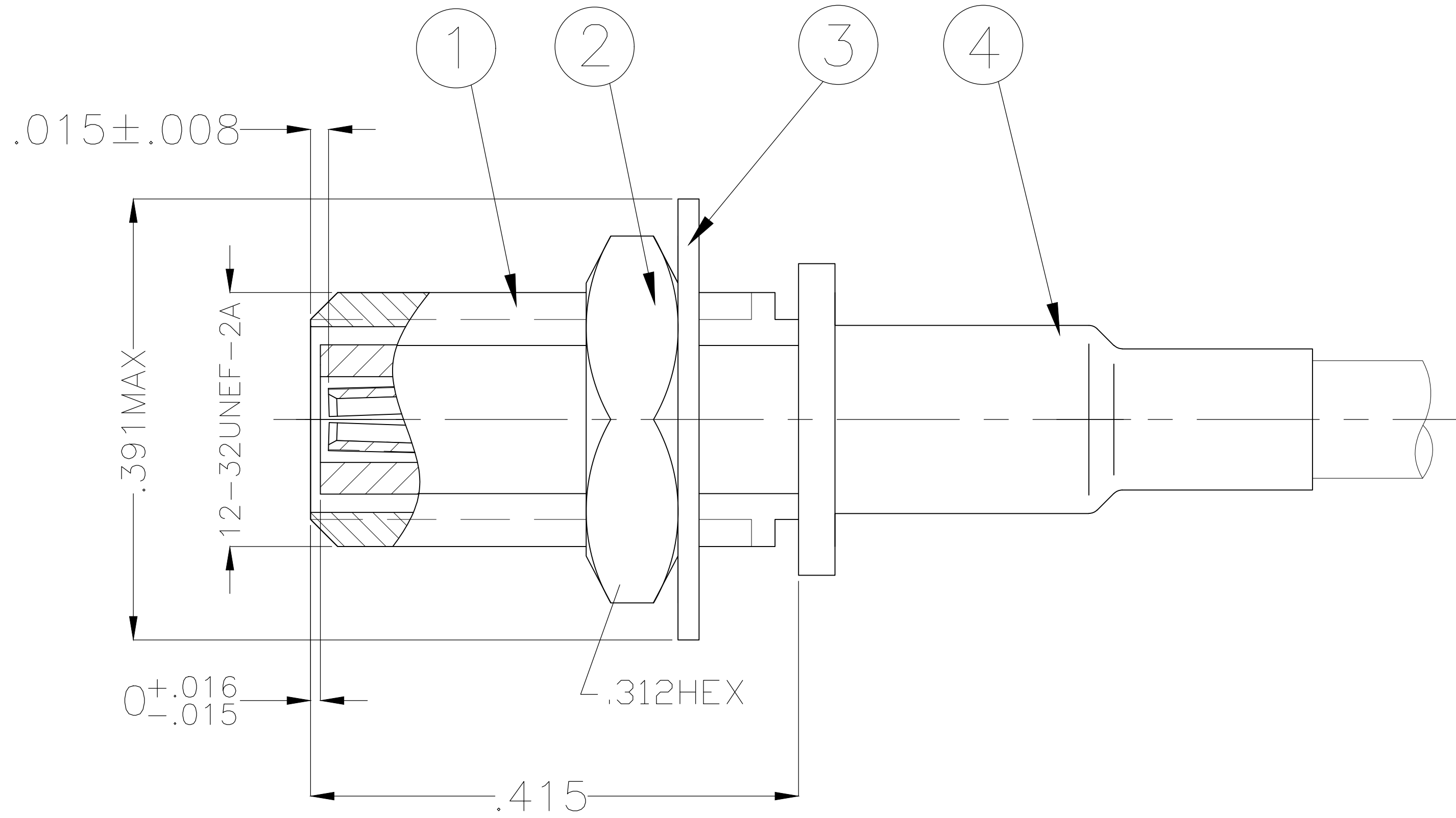
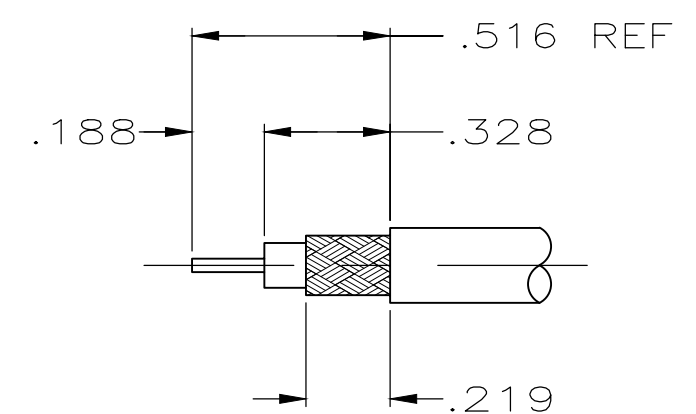

RECOMMENDED STRIP LENGTH

	45609 & 69142	RG-161/U,178/U,178A/U, & 196/U	5-329067-0	5-328691-0	5-328690-0	5-330347-0	7-330312-2
	69188-1	RG-174/U,179A/U,187/U,188/U,21-596, & 21-598	5-329038-0	5-328691-0	5-328690-0	5-330347-0	7-330312-1
	69188-1	RG-174/U,179A/U,187/U & 188/U	1-329038-3	1-328691-2	1-328690-2	222262-2	2-330312-8
	45609 & 69142	RG-161/U,178/U,178A/U, & 196/U	1-329067-1	1-328691-2	1-328690-2	222262-2	2-330312-7
OBSOLETE	69188-1	RG-161/U,178/U,178A/U, & 196/U	5-329067-0	5-328691-0	5-328690-0	415158-1	2-330312-6
OBSOLETE	45609 & 69142	RG-174/U,179A/U,187/U,188/U,21-596, & 21-598	5-329038-0	5-328691-0	5-328690-0	415158-1	2-330312-5
	45609 & 69142	RG-174/U,179A/U,187/U,188/U,21-596, & 21-598	5-329038-0	1-328691-3	1-328690-3	222262-1	2-330312-4
	69188-1	RG-161/U,178/U,178A/U, & 196/U	5-329067-0	1-328691-3	1-328690-3	222262-1	2-330312-3
OBSOLETE	69188-1	RG-161/U,178/U,178A/U, & 196/U	5-329067-0	5-328691-0	5-328690-0	5-330347-0	2-330312-2
	45609 & 69142	RG-174/U,179A/U,187/U,188/U,21-596, & 21-598	5-329038-0	5-328691-0	5-328690-0	5-330347-0	2-330312-1
	CRIMP TOOL	CABLE SIZE	④ FERRULE QTY=1	③ LOCKWASHER QTY=1	② JAM NUT QTY=1	① RECEPTACLE ASSEMBLY QTY=1	PART NO

1. .125 MAX PANEL THICKNESS  
 2. SEE I.S. 1771

THIS DRAWING IS A CONTROLLED DOCUMENT.

DIMENSIONS: INCHES	TOLERANCES UNLESS OTHERWISE SPECIFIED:	DWN L. MOSCOSO 9-14-89	 TE Connectivity CONNECTOR, RECEPTACLE SERIES MINIATURE THREADED
	0 PLC ± -	CHK R.E. RUTH 9-14-89	
	1 PLC ± -	APVD R. HENRY 9-14-89	
	2 PLC ± -	PRODUCT SPEC	
MATERIAL	FINISH	APPLICATION SPEC	RESTRICTED TO

WEIGHT 0.000000 A2 00779 C=330312  
 CUSTOMER DRAWING SCALE 5:1 SHEET 1 OF 1 REV T2