

NS 35/15 PERF 500MM - DIN rail perforated



1207657

<https://www.phoenixcontact.com/us/products/1207657>

Please be informed that the data shown in this PDF document is generated from our online catalog. Please find the complete data in the user documentation. Our general terms of use for downloads are valid.



DIN rail perforated, similar to EN 60715, material: Steel, galvanized, passivated with a thick layer, Standard profile, color: silver

Commercial data

Item number	1207657
Packing unit	1 pc
Minimum order quantity	20 pc
Sales key	BH84
Product key	BH8422
GTIN	4046356366557
Weight per piece (including packing)	310 g
Weight per piece (excluding packing)	310 g
Customs tariff number	72166190
Country of origin	DE

NS 35/15 PERF 500MM - DIN rail perforated



1207657

<https://www.phoenixcontact.com/us/products/1207657>

Technical data

Product properties

Product type	DIN rail
--------------	----------

Dimensions

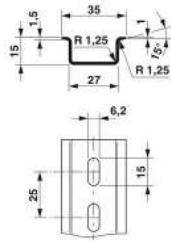
Dimensional drawing	
Width	35 mm
Hole width	15 mm
Height	15 mm
Hole height	6.2 mm
Length	500 mm
Drill hole spacing	25 mm

Material specifications

Color	silver
Material	Steel
Coating	galvanized, passivated with a thick layer

Standards and regulations

Tests	similar to EN 60715
-------	---------------------

NS 35/15 PERF 500MM - DIN rail perforated



1207657

<https://www.phoenixcontact.com/us/products/1207657>

Drawings

Dimensional drawing

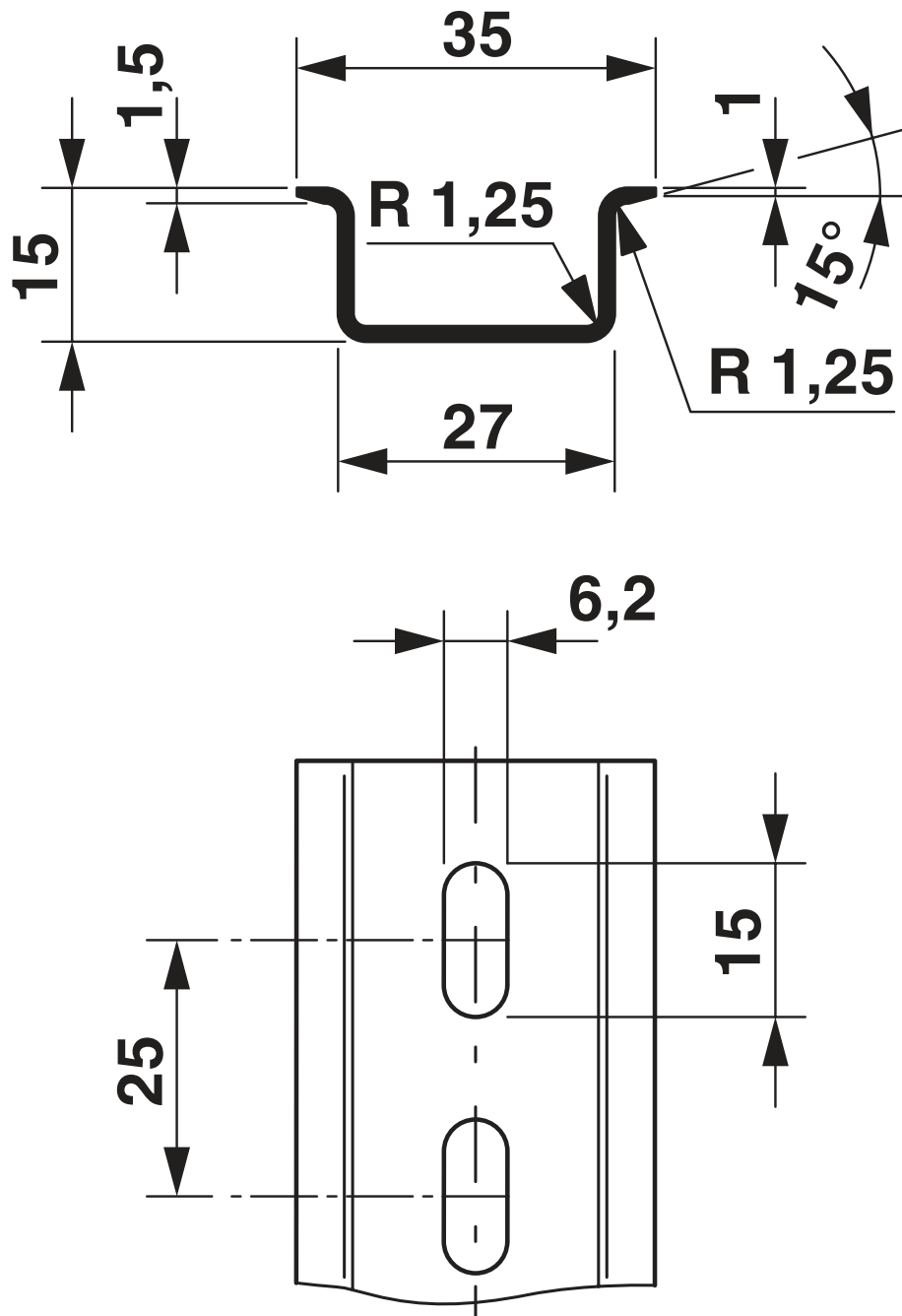

NS 35/15 PERF 500MM - DIN rail perforated



1207657

<https://www.phoenixcontact.com/us/products/1207657>

Classifications

ECLASS

ECLASS-11.0	27400602
ECLASS-13.0	27400602
ECLASS-12.0	27400602

ETIM

ETIM 8.0	EC001285
----------	----------

UNSPSC

UNSPSC 21.0	39121700
-------------	----------

NS 35/15 PERF 500MM - DIN rail perforated



1207657

<https://www.phoenixcontact.com/us/products/1207657>

Environmental product compliance

China RoHS	Environmentally friendly use period: unlimited = EFUP-e No hazardous substances above threshold values
------------	-----------------------------------------------------------------------------------------------------------

Phoenix Contact 2023 © - all rights reserved
<https://www.phoenixcontact.com>

Phoenix Contact USA
586 Fulling Mill Road
Middletown, PA 17057, United States
(+717) 944-1300
info@phoenixcon.com