

THIS DRAWING IS UNPUBLISHED. RELEASED FOR PUBLICATION
 © COPYRIGHT - BY TYCO ELECTRONICS CORPORATION. ALL RIGHTS RESERVED.

LOC		DIST		REVISIONS			
P	LTR	DESCRIPTION	DATE	DWN	APVD		
	A	DRAWING RELEASED PER ECR-11-017294	22AUG2011	JvdH	TdB		

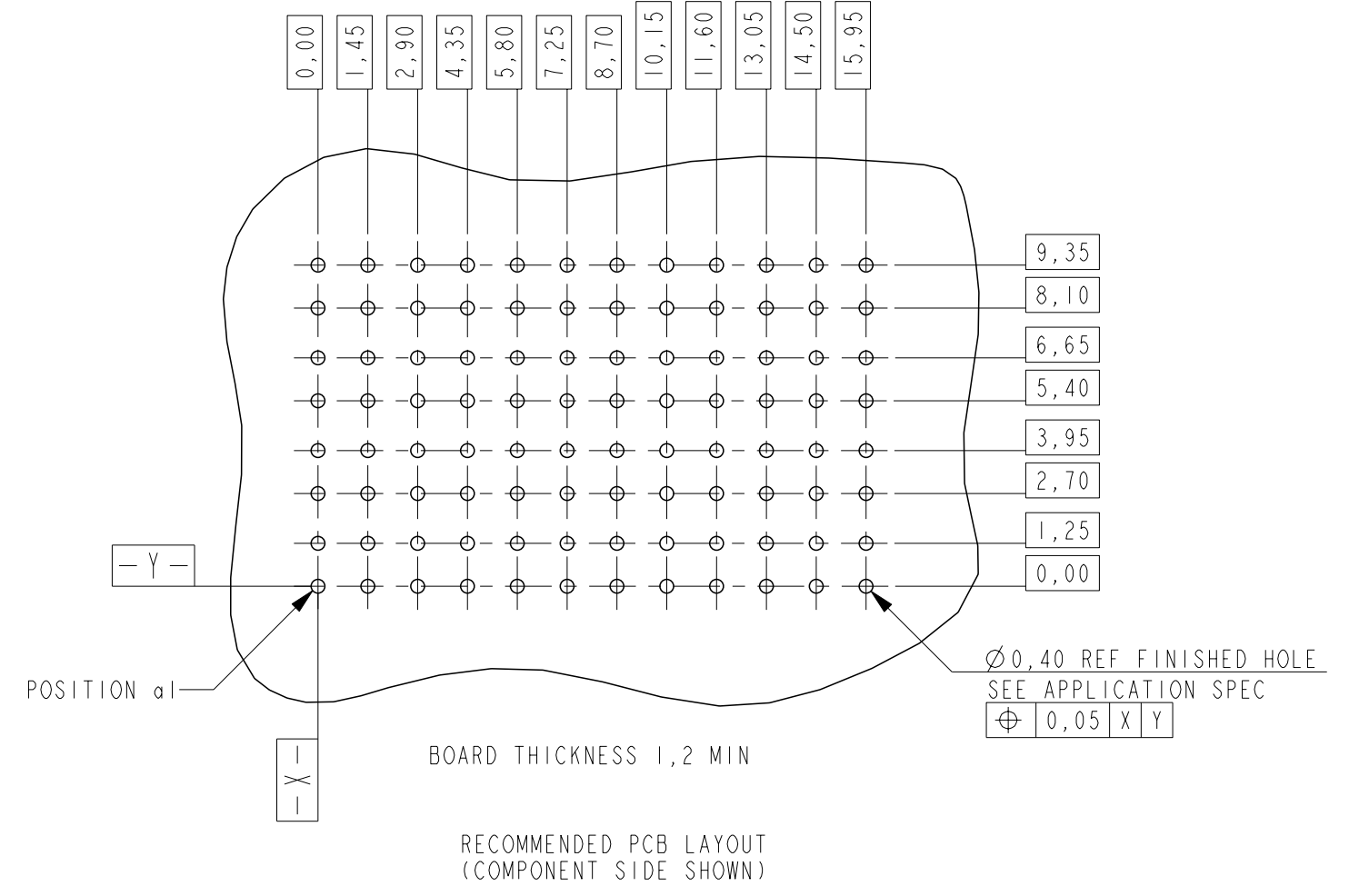
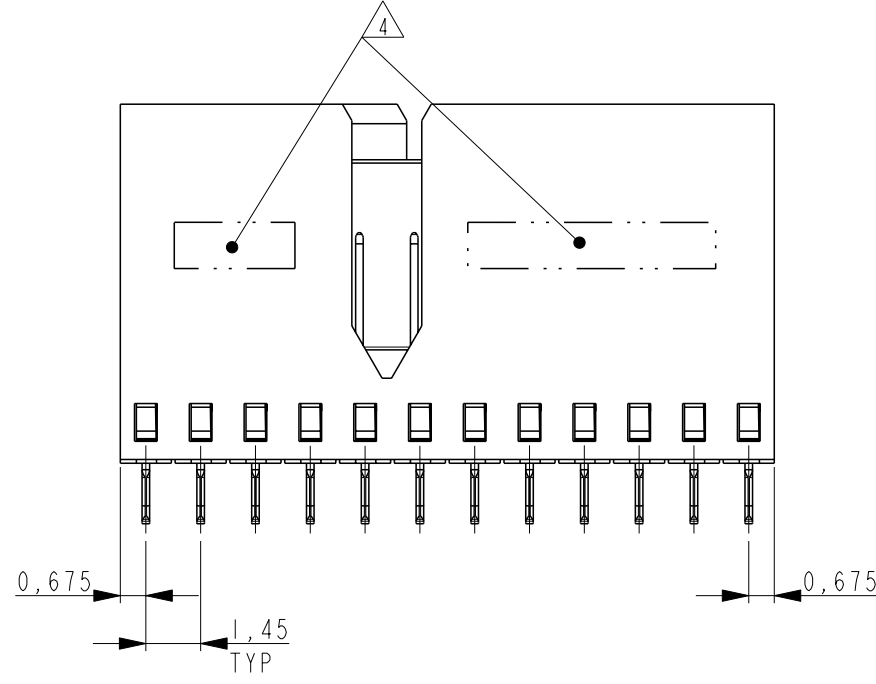
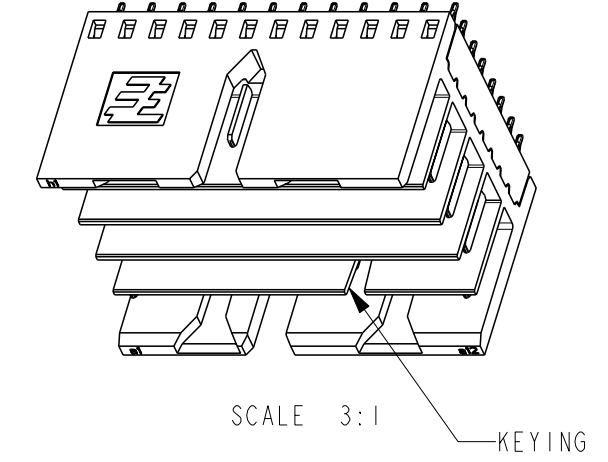
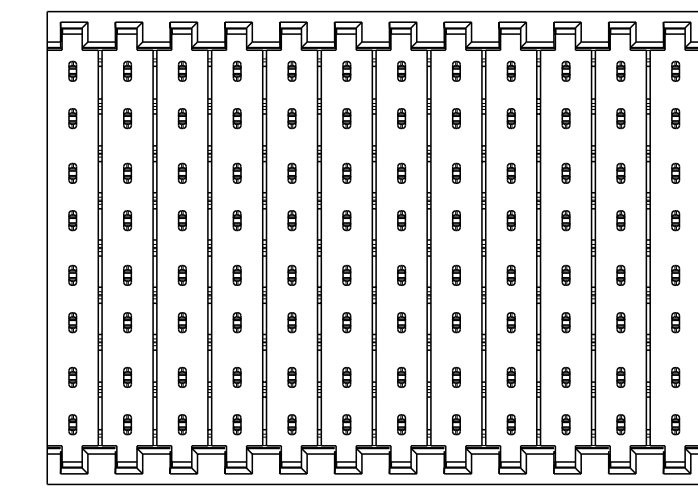
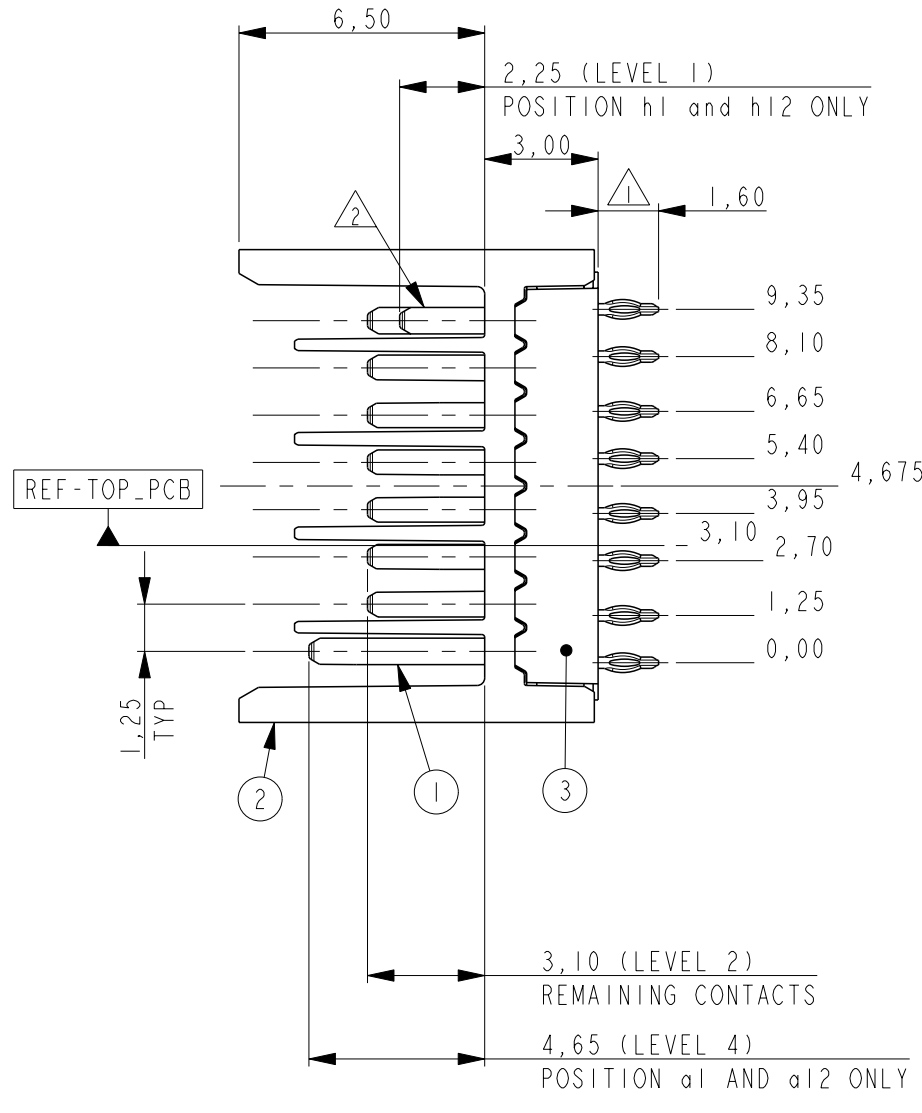
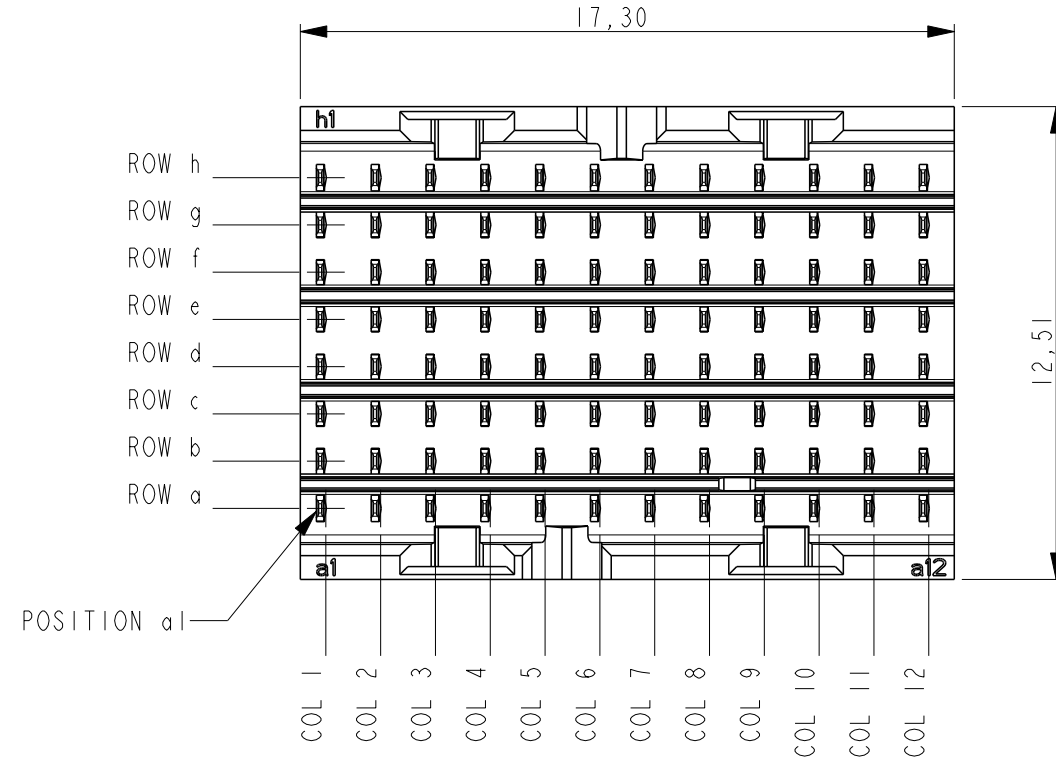
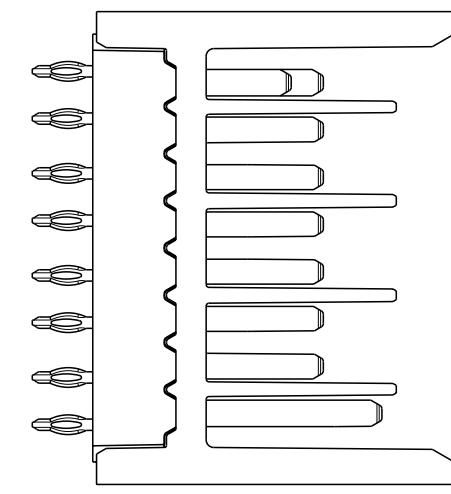
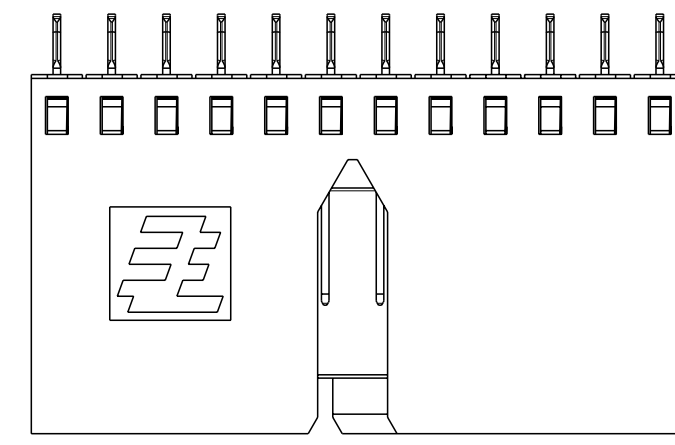

NOTES:

- 1 PLATING: 0,5µm MIN. TIN OVER NICKEL.
- 2 PLATING:

PARTNUMBER	PERFORMANCE LEVEL
2173043-1	PERFORMANCE LEVEL 1: CONNECTOR TESTED AND QUALIFIED AGAINST TELCORDIA GR-1217-CORE QUALITY LEVEL 111: UNCONTROLLED ENVIRONMENT APPLICATIONS. SEE PRODUCT SPEC 108-19353
2173043-2	PERFORMANCE LEVEL 2: CONFORMS TO ALL TESTING ACCORDING PRODUCT SPEC 108-19320, -250 MATING CYCLES, 4 DAYS MIXED GAS TEST PER IEC 60068-2-60 METHOD 1

PRODUCT HAS NOT COMPLETED QUALIFICATION TESTING

- 3 CONSULT APPLICATION SPEC OR CONTACT TE CONNECTIVITY FOR PERMISSIBLE CONTACT ASSIGNMENTS.
- 4 CONNECTOR MARKED WITH PARTNUMBER AND DATE CODE.
- 5 FOR PC-BOARD ROUTING RECOMMENDATIONS SEE SPEC 114-19140

THIS DRAWING IS A CONTROLLED DOCUMENT.		DWN	J.V.D. HELJDEN	04 MAR 2011
DIMENSIONS: mm		CHK	B.MOOLJ	04 MAR 2011
TOLERANCES UNLESS OTHERWISE SPECIFIED:		APVD	I.D. BOER	07 MAR 2011
0 PLC ±		PRODUCT SPEC	SEE NOTE 2	
1 PLC ±		APPLICATION SPEC	114-19106	
2 PLC ±		WEIGHT	-	
3 PLC ±		CUSTOMER DRAWING		
4 PLC ±				
ANGLES ±				
FINISH ±				

3	OVERMOLD	LCP 30% GF NATURAL
2	HOUSING	LCP 30% GF NATURAL
1	CONTACT	COPPER ALLOY
ITEM NO.	DESCRIPTION	MATERIAL
STE TE Connectivity		
NAME MALE CONNECTOR Z-PACK Slim UHD		
SIZE	CAGE CODE	DRAWING NO
A2	00779	C-2173043
RESTRICTED TO	SCALE	SHEET OF REV
-	5:1	1 OF 1 A