

Miniature push-pull connectors with ground function

MXR Series

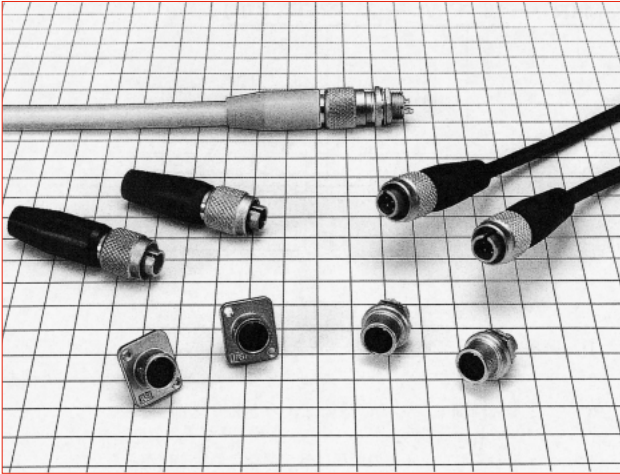

■ Features

1. User friendly lock mechanism

The single action push-pull lock function allows quick connections and disconnections as well as high density mounting.

2. Grounding function for FCC compliance

Metal, outer shell provides stable contact for grounding.

3. Sequential contact structure

A sequential mating type is available. This version allows for the contacts to mate in a sequenced order.

■ Product Specifications

Ratings	Rated current	Number of contacts		Rated current
		3		2A
		4		
		6		
	8			
	Rated voltage	Number of contacts		Rated voltage
3		AC 100, DC 140V		
4				
6				
8				
Operating temperature range		-25 to +85°C		
Storage temperature range		-10 to +60°C		

Items	Specifications	Conditions
1. Contact resistance	A maximum of 20mΩ	Measured at DC 1A
2. Insulation resistance	A minimum of 1,000MΩ	Measured at DC 100V
3. Withstanding voltage	No flashover or dielectric breakdown.	AC 300V for 1minute
4. Vibration resistance	No electrical discontinuity for 10μs or greater.	10 to 55Hz/cycle, amplitude : 0.75mm, 3 axis directions, 2 hours each
5. Shock resistance	No electrical discontinuity for 10μs or greater.	Acceleration : 490m/s ² , duration : 11ms, 3 axis directions, 3 times each
6. Mating cycles	Contact resistance : a maximum of 40mΩ	1,000 times
7. Temperature cycle	Insulation resistance : a minimum of 1,000MΩ	-55°C : 30 minutes → Normal temperature : 10 to 15 minutes → 85°C : 30 minutes → Normal temperature : 10 to 15 minutes, left for 5 cycles
8. Moisture resistance	Insulation resistance : a minimum of 10MΩ (at high humidities) a minimum of 100MΩ (when dry)	Temperature : 40°C, relative humidity : 90 to 95%, left for 96 hours

■ Materials / Finish

Part	Material	Finish	Remarks
Shell	Aluminum alloy	Nickel plating	————
Insulator	PBT resin	————	UL94V-0
Contact	Copper alloy	Gold plating, partial gold plating	————

Product Number Structure

Refer to the chart below when determining the product specifications from the product number.
Please select from the product numbers listed in this catalog when placing orders.

MXR - 8 P A - 3 P B ()**

① ② ③ ④ ⑤ ⑥ ⑦ ⑧

① Series name : MXR Series
② Shell size : Indicates the outer shell diameter at the mating end.
③ Shell classification : Classified as follows P : Plug R : Receptacle
④ Shell modification : The letters A, B, C, D, E, etc. indicate modifications of the shell form.
⑤ Pin arrangement : Indicated by the number of pins
⑥ Pin form : Classified as follows P : Male contacts S : Female contacts
⑦ Pin modification : The letters A, B, C, D, E, etc. indicate modifications of the pin form.
⑧ Special specifications : A two-digit number is added to indicate other specifications, such as (01), (02), (03)...

Plug

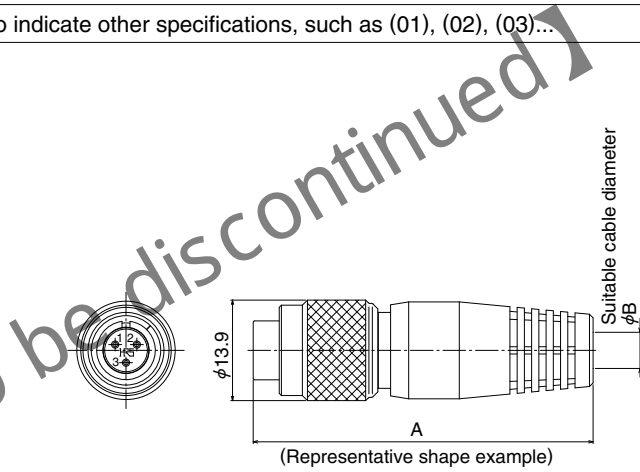

Part No	HRS No.	A	φB	Weight	Bushing	Remarks
MXR-8PA-3PB(71)	127-0003-6 71	47	5	8g	Black	Sequenced construction
MXR-8PA-4PB(71)	127-0004-9 71					
MXR-8PA-6PB(71)	127-0005-1 71					
MXR-8P-8P(31)	127-0002-3 31	50	8	9g	White	_____
MXR-8P-8P(72)	127-0002-3 72					_____

Note : Cable pull force, twisting strength and other characteristics may differ, depending on cable specifications and structure.
Please evaluate under the actual conditions prior the use.

Receptacle (Secured with hex nut for mounting)

● Solder termination

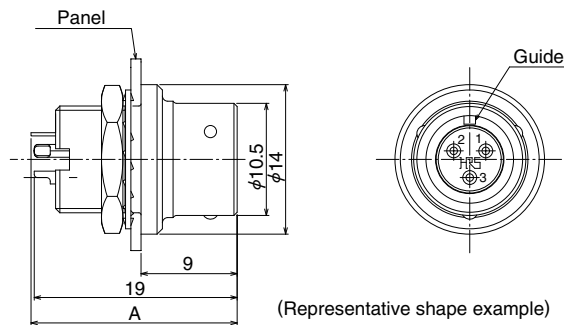

Part No.	HRS No.	Weight	A	Remarks
MXR-8RA-3S(71)	127-0121-2 71	3.5g	19.3	_____
MXR-8RA-4S(71)	127-0122-5 71			_____
MXR-8RA-6S(71)	127-0123-8 71			_____
MXR-8RA-8S(71)	127-0124-0 71			_____
			20.4	

■ Receptacle (Flange type)

● Dip termination

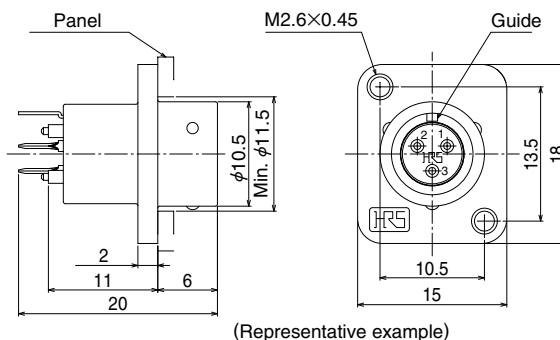

Part No.	HRS No.	Weight	Remarks
MXR-8R-3SA(71)	127-0101-5 71	3.5g	with gold-plated contacts
MXR-8R-4SA(71)	127-0103-0 71		
MXR-8R-6SA(71)	127-0104-3 71		
MXR-8R-8SA(71)	127-0102-8 71		

◆ Layout dimensions for dip post contacts

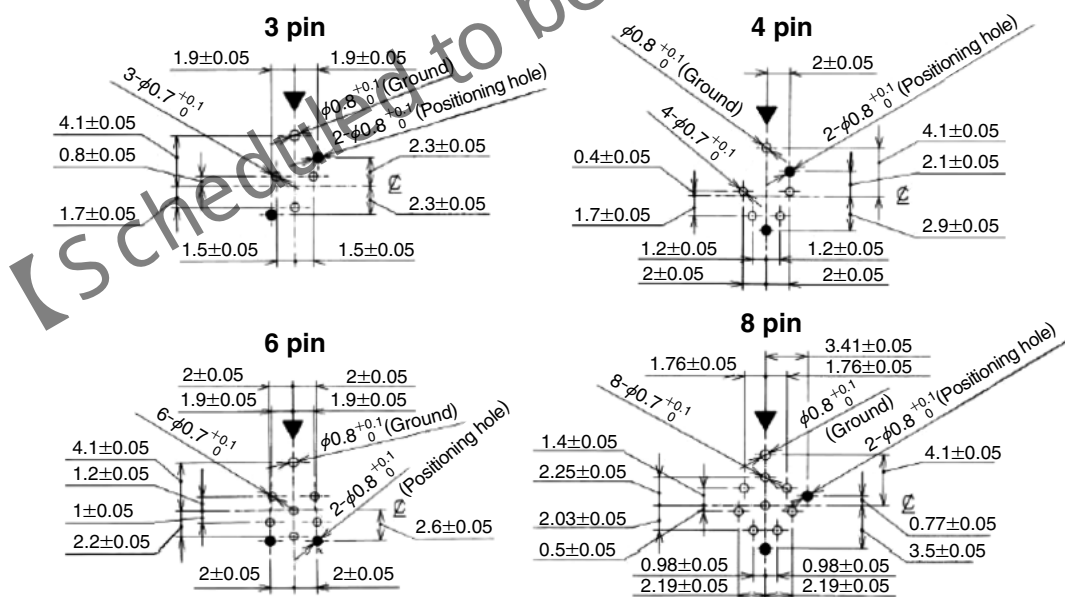

Remarks : Figures are views from the mating side of the receptacle.
 Marks ▼ show the position of the guide.

Aug. 1. 2023 Copyright 2023 HIROSE ELECTRIC CO., LTD. All Rights Reserved.

◆ Wiring and Assembly Procedure

● MXR-8PA-3PB(71), MXR-8PA-4PB(71), MXR-8PA-6PB(71)

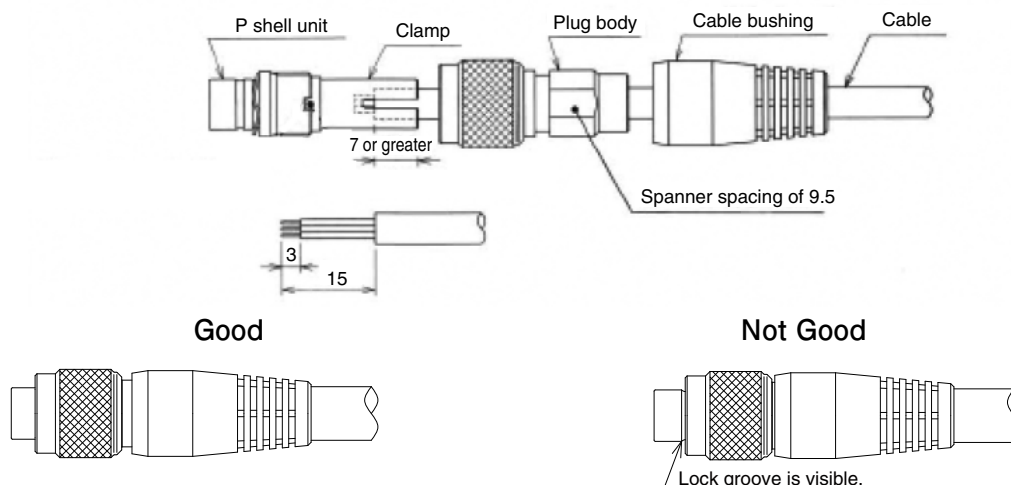

○ Work Procedure

1. Pass the cable through the components in this order : 1. cable bushing, 2. plug body, 3. clamp fitting. Then perform the cable end processing.
2. Solder the wires to the P shell unit.
3. Align the protruding portion of the clamp with the recessed portion of the P shell unit and mount.
4. Align the plug and cable sheath strip position, then tighten the plug body to the screw portion of the P shell unit with a torque of 1 N·m.
Note that to prevent loosening, an application of Locktight 263 manufactured by HENKEL JAPAN LTD. is recommended.
5. Put the cable bushing over the clamp body to complete the job.
6. Make sure that the lock groove is not visible after assembly is completed.
If you can see the lock groove, the P-shell unit and the threaded portion of plug body may not be assembled correctly.

● MXR-8P-8P(**)

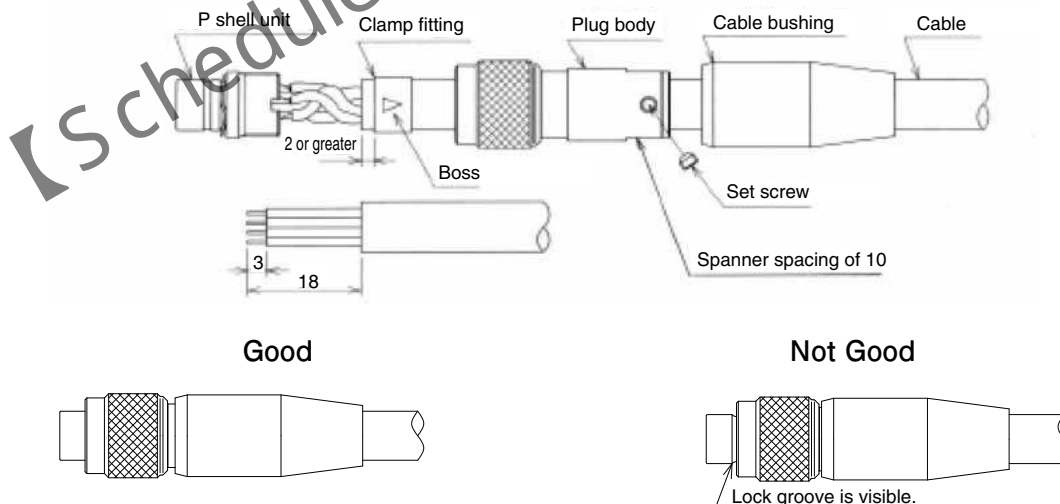

○ Work Procedure

1. Pass the cable through the components in this order : 1. cable bushing, 2. plug body. Then perform the cable end processing.
2. Solder the wires to the P shell unit.
3. Fasten the clamp fitting to the cable with the cable crimping tool (HR10A-TC-04).
4. Tighten the clamp body to the screw portion of the P shell unit with a torque of 1 N·m.
Note that to prevent loosening, an application of Locktigh 263 manufactured by HENKEL JAPAN LTD. is recommended.
5. Tighten the set screw so that the tip falls into one of the two bosses of the clamp fitting.
Note that a tightening torque of 0.3 N·m. is specified.
6. Put the cable bushing over the clamp body to complete the job.
7. Make sure that the lock groove is not visible after assembly is completed.
If you can see the lock groove, the P-shell unit and the threaded portion of plug body may not be assembled correctly.

◆ Dimensions for receptacle mounting holes

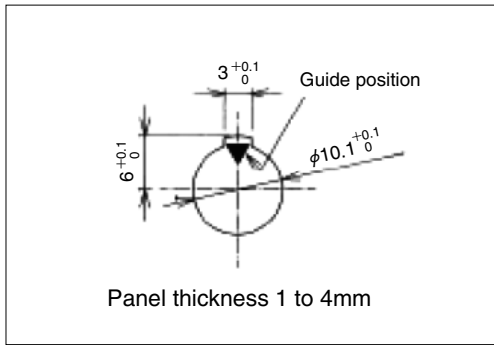

(Jam Nut Type)

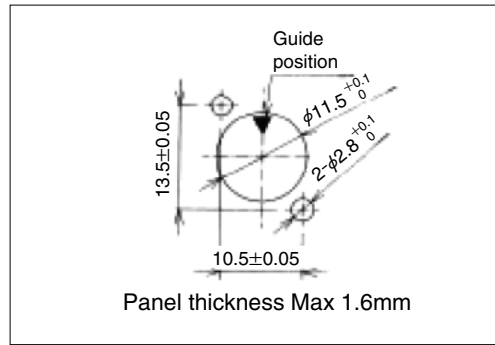

(Flange Type)

NOTES :

- Above figures are views from the mating side of the receptacle.
Also note that the ▼ symbol indicates the guide position.

◆ Applicable Tools

Type	Part No.	HRS No.	Applicable Connectors
Tightening jig	MXR-8P-T01	150-0092-3	All plug products
Cable crimping tool	HR10A-TC-04	150-0058-5	MXR-8P-8P (**)

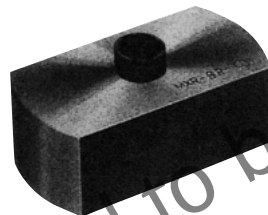

MXR-8P-T01



HR10A-TC-04

◆ Pin arrangement and electrical specifications

Number of contacts	3	4	6	8
Pin arrangement				
Withstanding voltage	300V AC for 1minute			
Current capacity	2A			
Insulation resistance	1,000MΩ or greater at 100V DC			
Contact resistance	20mΩ or less at 1A DC			
Solder pot diameter	0.9mm dia.			

NOTES :

- Above figures are views from the mating side of the receptacle.
Also note that the ▼ symbol indicates the guide position.
- The withstand voltage value indicates the test voltage.
The connector should normally be used at less than 100V AC or 140V DC.

MEMO :

【Scheduled to be discontinued】

HIROSE ELECTRIC CO.,LTD.

2-6-3,Nakagawa Chuoh,Tsuzuki-Ku,Yokohama-Shi 224-8540,JAPAN
<https://www.hirose.com/>
