

REVISIONS			
REV	DESCRIPTION, ECN, EAR NO.	DATE	APP'D
A	PROPOSAL DRAWING	JUN13/14	L.CHAN
B	PROPOSAL DRAWING	MAR16/15	L.CHAN

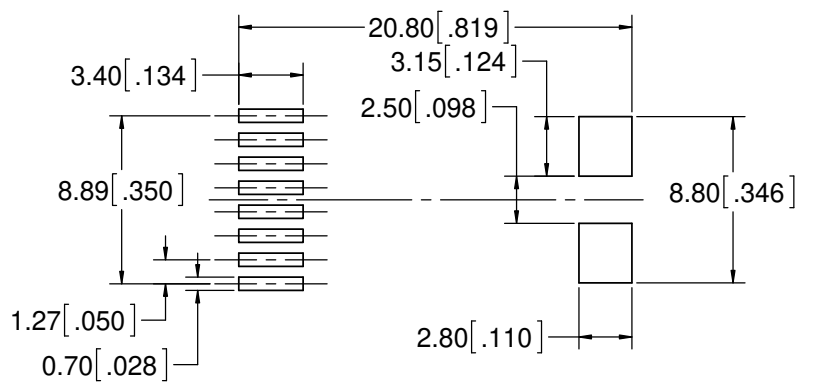
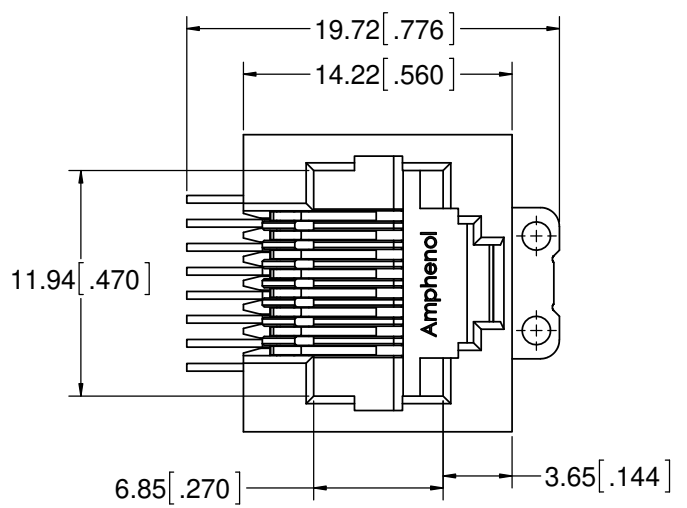

**RECOMMENDED P.C.B LAYOUT**  
 (COMPONENT SIDE OF BOARD)  
 TOLERANCE: ±0.05[.002]

**NOTE:**

- MATERIALS:**  
 HOUSING: HIGH TEMPERATURE THERMOPLASTIC, FLAMMABILITY RATING UL94 V-0, COLOUR: BLACK  
 CONTACTS: PHOSPHOR BRONZE  
 PLATING: SELECTIVE GOLD PLATING ON MATING SURFACES;  
 100u" [2.54 MICRONS] MIN. MATTE TIN ON SOLDER TAILS;  
 50u" [1.27 MICRONS] MIN. NICKEL UNDERPLATING OVERALL.  
 SOLDER BRACKET: STAINLESS STEEL  
 PLATING: MATTE TIN OVER ALL
- COPLANARITY SPECIFICATION:**  
 THE MAX GAP BETWEEN ALL TERMINAL TAILS & SOLDER BRACKET IS 0.10[.004]

AMPHENOL PART NUMBER: RJE23-188-0X13-T

- GOLD PLATING OPTION**
- 1=6u" [0.15 MICRONS] GOLD PLATING
  - 2=15u" [0.38 MICRONS] GOLD PLATING
  - 3=30u" [0.76 MICRONS] GOLD PLATING
  - 4=50u" [1.27 MICRONS] GOLD PLATING

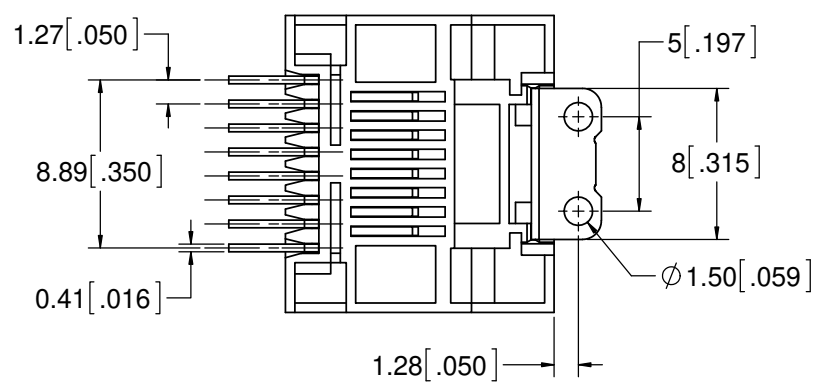
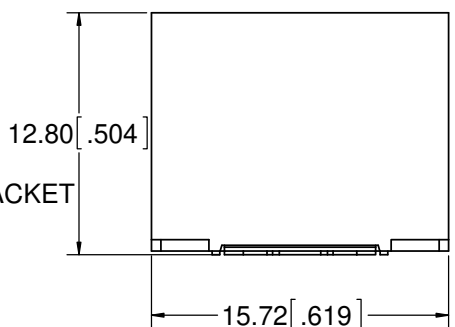
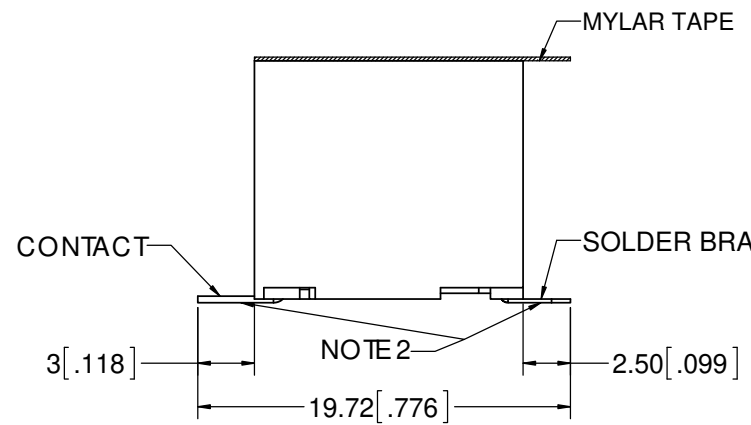

UNLESS SPECIFIED OTHERWISE	DRAWN	J.FENG	JUN13/14
PRIMARY UNITS	MILLIMETERS	CHECKED	L.CHAN
SECONDARY	INCHES	M.E. APP'D	
REFERENCE IN PARENTHESES	Q.A. APP'D		
GENERAL TOLERANCES IN MM	DWG APPR.	L.CHAN	JUN13/14
1 DECIMAL PLACE	ENG. REL. NO.		
2 DECIMAL PLACES	REF.		
3 DECIMAL PLACES	THIRD ANGLE PROJECTION		
ANGULAR DEGREES	DO NOT SCALE DRAWING		

**Amphenol Canada Corp.**

**TITLE:**  
 TOP ENTRY MODULAR JACK, SURFACE MOUNT,  
 8 POSITIONS, 8 CONTACTS, WITH MYLAR TAPE,  
 T&R PACKAGE-RoHS COMPLIANT

DWG. NO.	P-RJE23-188-0X13-T	REV	B
CODE ID. NO.	03554	DWG. SIZE:	C
SCALE:	5:1	SHEET	1 OF 2

REVISIONS			
REV	DESCRIPTION, ECN, EAR NO.	DATE	APP'D
A	PROPOSAL DRAWING	JUN13/14	L.CHAN
B	PROPOSAL DRAWING	MAR16/15	L.CHAN

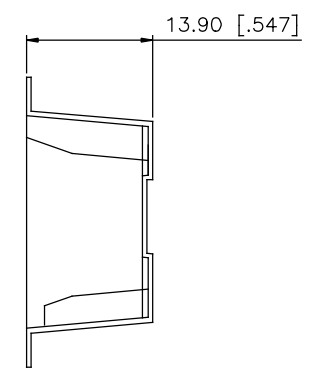
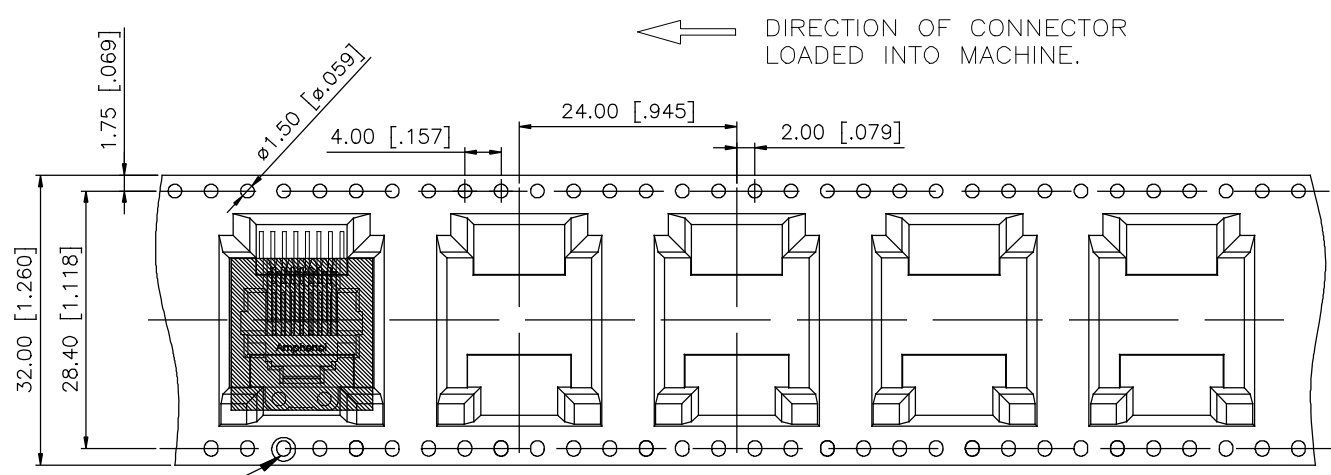

TOP VIEW  
(COVER TAPE NOT SHOWN)  
(SHOWN WITH RJE23 8 POSITION CONNECTOR)

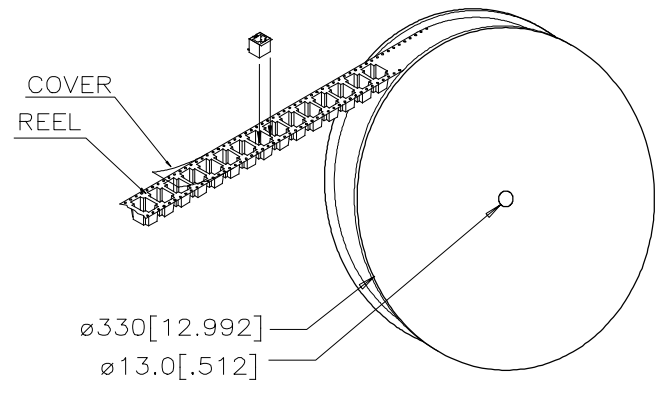
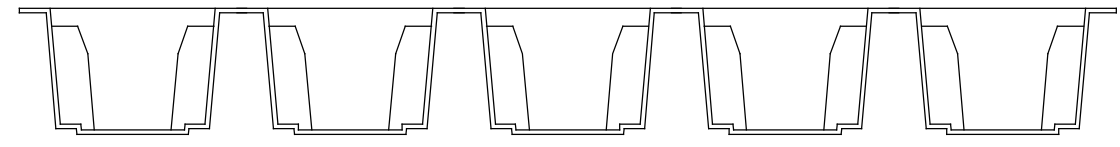
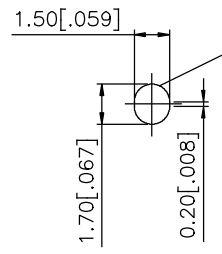

PACKAGING NOTES:

1. ONE REEL SHOULD HOLD 200 CONNECTORS.
2. 5 EMPTY CAVITIES FOR CARRIER TAPE LEADER & 7 EMPTY CAVITIES FOR CARRIER TAPE TRAILER.
3. A FULLY LOADED CARTON SHOULD CONTAIN 7 REELS(1400 PCS) OF CONNECTORS.

UNLESS SPECIFIED OTHERWISE	DRAWN Justin Feng	JUN13/14	Amphenol Canada Corp. www.amphenolcanada.com
PRIMARY UNITS MILLIMETERS	CHECKED L.Chan	JUN13/14	
SECONDARY INCHES	M.E. APP'D		TITLE: TOP ENTRY MODULAR JACK, SURFACE MOUNT, 8 POSITIONS, 8 CONTACTS, WITH MYLAR TAPE, T&R PACKAGE-ROHS COMPLIANT
REFERENCE IN PARENTHESES	Q.A. APP'D		
GENERAL TOLERANCES FOR MM	DWG APP'D		DWG NO. P-RJE23-188-0X13-T
1 DECIMAL PLACE ±0.38	ENG. REL. NO.		
2 DECIMAL PLACE ±0.25	REF.		REV B
3 DECIMAL PLACE ±0.13	THIRD ANGLE PROJECTION	DO NOT SCALE DRAWING	
ANGULAR DEGREES ±1.5°			CODE ID NO. Q3554 DWG SIZE: C SCALE: N/A SHEET 2 OF 2