

THIS DRAWING IS UNPUBLISHED. RELEASED FOR PUBLICATION 20  
 © COPYRIGHT BY ALL RIGHTS RESERVED.

LOC	DIST	REVISIONS				
P	LTR	DESCRIPTION	DATE	DWN	APVD	
FT	0	E1	REVISE D PER ECO-11-005294	30APR11	RK	HMR

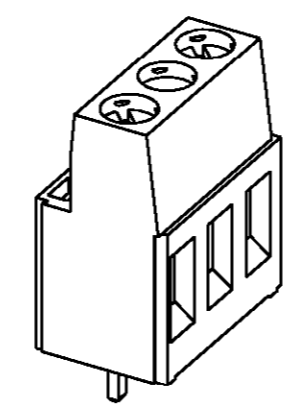
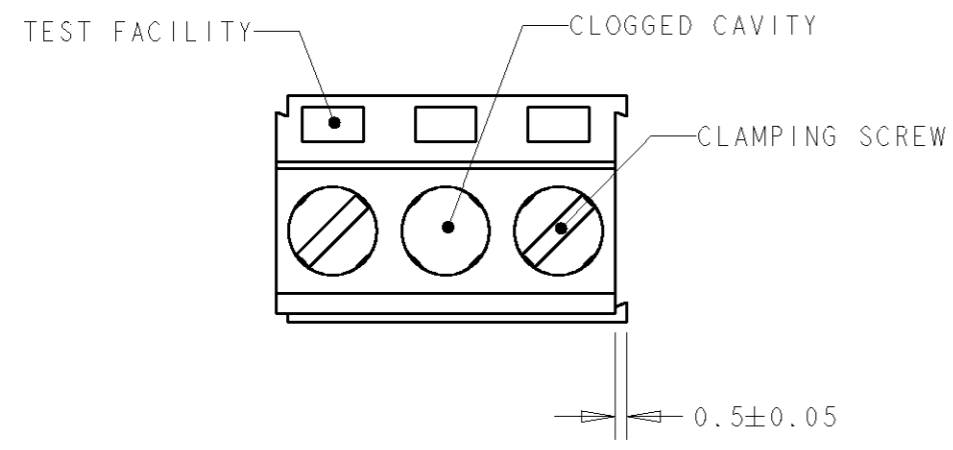

282858-2 AS SHOWN  
 SCALE 2:1

- 1 MATERIALS AND FINISH  
 HOUSING: PA 6-6, UL 94-V0, COLOR GREEN.  
 CLAMP: BRASS, NICKEL PLATED.  
 TERMINAL: BRASS, TIN PLATED.  
 CLAMPING SCREW: M3, BRASS, NICKEL PLATED.
- 2 SUITABLE FOR 1,6-2,4mm PC BOARD THICKNESS.
- 3 WIRE SIZE RANGE  
 SOLID WIRE: 0,03-4mm<sup>2</sup> (11AWG).  
 STRANDED WIRE: 0,03-2,5mm<sup>2</sup> (13AWG).
- 4 RECOGNIZED UNDER THE COMPONENT PROGRAM OF UNDERWRITERS LABORATORIES INC. FILE N° E60677.
- 5 IMQ CERTIFICATE WITH SURVEILLANCE IN CONFORMITY WITH IEC 998-1/998-2-1.
- 6 NOT CUMULATIVE TOLERANCE.

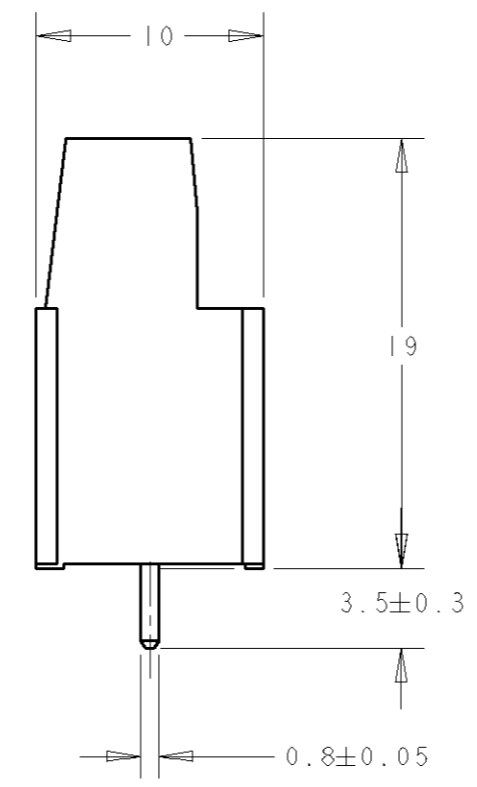
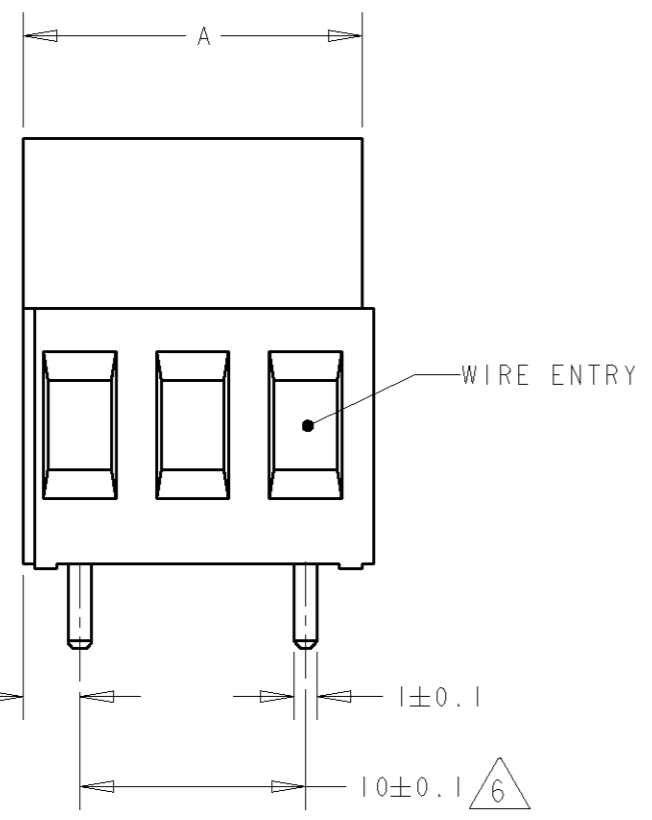

125	13	1-282858-3
115	12	1-282858-2
105	11	1-282858-1
95	10	1-282858-0
85	9	282858-9
75	8	282858-8
65	7	282858-7
55	6	282858-6
45	5	282858-5
35	4	282858-4
25	3	282858-3
15	2	282858-2
DIM. A	N° OF POS.	PART NUMBER

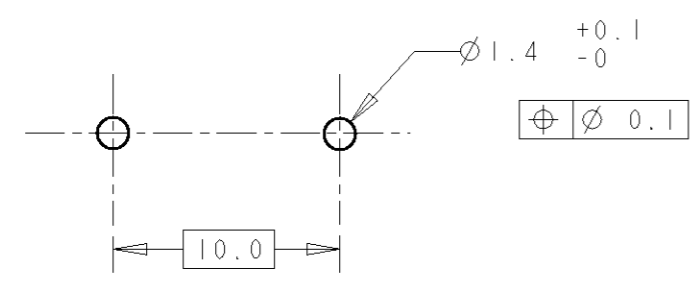

RECOMMENDED PC BOARD LAYOUT

DIMENSIONS: mm 		TOLERANCES UNLESS OTHERWISE SPECIFIED: 0 PLC ± 1 PLC ±.3 2 PLC ±.25 3 PLC ± 4 PLC ± ANGLES ±2		DWN 05SEP2001 E. ZANOLINI CHR 05SEP2001 D. BIEVENOUR APVD 05SEP2001 D. BIEVENOUR PRODUCT SPEC 108-20166 APPLICATION SPEC 114-20079 WEIGHT -			
MATERIAL 1 		FINISH 1 		NAME TERMINAL BLOCK, PCB MOUNT, SIDE ENTRY WIRE, 10.0mm PITCH		SIZE A3 CAGE CODE 00779 DRAWING NO C=282858 RESTRICTED TO -	
CUSTOMER DRAWING				SCALE 3:1		SHEET 1 OF 1 REV E1	