

## PIC18F67J94 Development Board

*Author: Stephen Allen  
Microchip Technology Inc.*

### INTRODUCTION

This development board has been created to demonstrate many of the capabilities of the PIC18F97J94 processor family (specifically, the PIC18F67J94 device), including:

- Direct LCD drive, using a 4-common LCD display
- Serial interfacing, using the SPI protocol to interface with an accelerometer and an IEEE 802.15.4 radio
- Use of the CTMU (Charge-Time Measurement Unit) to perform capacitive touch sensing.
- Low-power operation, using a single 1.5V AA battery as a power source (in conjunction with voltage boosting chip)
- USB HID bootloader, allowing programming through a USB cable (without requiring a programmer)

In order to demonstrate the capabilities of the demonstration board, a simple dancing game has been developed. See [Section "Dance Game"](#).

### LCD DISPLAY

A 4-common, 4-digit LCD display (Lumex #LCD-S401M16KR) is being used to display the score. The PIC18F67J94 can support up to 8-common displays, but 4-common is a very popular configuration among LCD displays. The PIC18F67J94 also has the capability to drive many more segments, but this provides a starting point for many LCD applications.

Individual segments can be controlled using [Table 1](#) (see LCD-S401M16KR data sheet for bit explanations):

**TABLE 1:**

Register	Bit 7	Bit 6	Bit 5	Bit 4	Bit 3	Bit 2	Bit 1	Bit 0
LCDDATA0	COL	4D	DP3	3D	DP2	2D	DP1	1D
LCDDATA8	4C	4E	3C	3E	2C	2E	1C	1E
LCDDATA16	4B	4G	3B	3G	2B	2G	1B	1G
LCDDATA24	4A	4F	3A	3F	2A	2F	1A	1F

The image below ([Figure 1](#)) shows the development board with many of the main board components indicated.

**FIGURE 1: DEVELOPMENT BOARD**

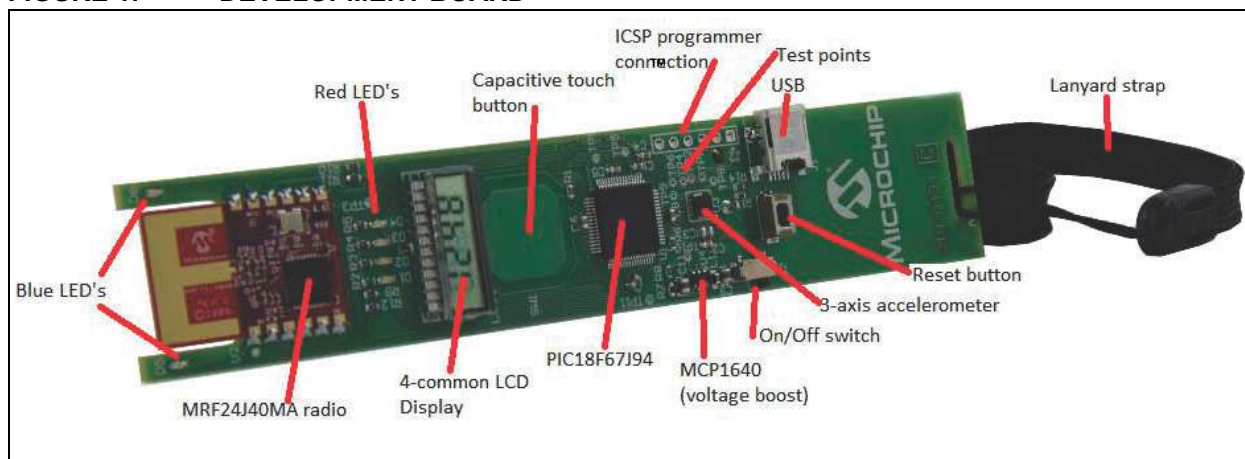

## IEEE 802.15.4 RADIO

Wireless communication is provided through an MRF24J40MA module, and uses the MiWi<sup>®</sup> P2P protocol. The MRF24J40MA transceiver allows for easy wireless interfacing and communicates with the microcontroller through an SPI interface. The software stack for the MiWi protocol is available as part of the Microchip Library for Applications. It should be noted that the software stack has some modifications from the standard library release, so the files provided in the downloaded (source code package) directory should not be replaced with files in the MLA release. More information can be found on the MRF24J40MA product page.

## ACCELEROMETER (MOTION SENSING)

A 3-axis accelerometer ST #LIS331DL is used for motion sensing. Deltas in acceleration are recorded and flagged as an event, if the magnitude is above a certain threshold (SIGMA). Motion is detected when a change in acceleration (delta) occurs. If the delta is above a predetermined threshold (SIGMA), it is flagged as an event. Acceleration deltas are used instead of using acceleration directly because acceleration due to the force of gravity is always present. If the readings were used directly, the measurement of gravity would interfere with comparison of the measurements.

The accelerometer data is read out via an SPI interface. The SPI signals (CS, SCK, SDI, SDO) are available through test points on the board. The accelerometer is configured to generate an interrupt on the INT1 pin when accelerometer data is available. Accelerometer data is available at a 100 Hz sample rate.

## USB HID BOOTLOADER

To allow ease of reprogramming, the development board supports a USB HID bootloader. The USB bootloader is available separately, as a part of the Microchip Library for Applications, “Device – Bootloader – HID” demonstration project. The HID bootloader application will run on Windows<sup>®</sup>, Mac<sup>®</sup>, and Linux systems and allows programming of new firmware through a USB cable.

To put the development board into Bootloader mode, simply connect a USB cable. Rapid blinking of LEDs D3 and D4 indicate that the USB connection is successful. The screenshot below shows bootloader messages after successful reprogramming of the PIC18F67J94 development board.

FIGURE 2: USB BOOTLOADER WINDOW

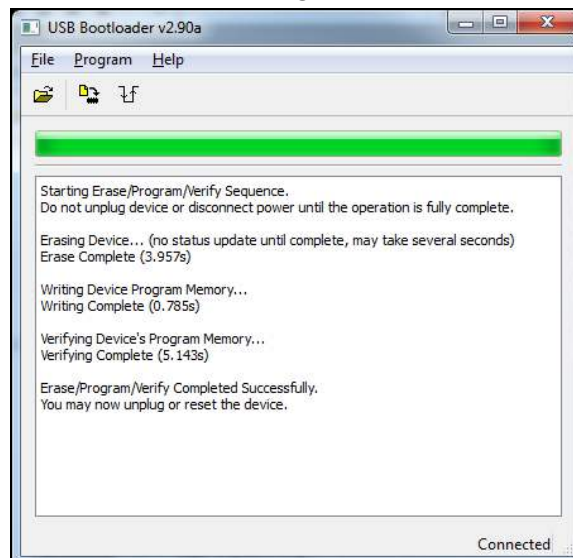

The bootloader code resides in the lower part of program memory (locations 0-0x0FFF). If the bootloader is mistakenly overwritten, it can be reprogrammed into the device through the programming connector, by programming the “*HID Bootloader PIC18F67J94.hex*” file into the device. This file can be found in the “HID bootloader” project directory.

It should be noted that the bootloader application code provided with the PIC18F67J94 demonstration board has been slightly modified from the bootloader that is in the Microchip Library for Applications release. The bootloader is not entered with a key press, but is entered by connecting the USB cable. When a USB cable is connected, it causes a high signal to be present on the RF7 pin. Be sure to use only the bootloader (.hex file) that is contained in the project directory.

## PROGRAMMING/DEBUG INTERFACE

As an alternative to the bootloader, full programming and debug support is available through header J2. Developers will need to install the header pins in order to connect using one of Microchip’s programmers (PICkit<sup>™</sup> 3, MPLAB<sup>®</sup> REAL ICE, or MPLAB ICD3). If the bootloader is accidentally deleted from memory, the bootloader can only be reprogrammed with the use of an external programmer through the J2 programming header.

## POWER

Power is supplied by a single 1.5V AA battery. An MCP1640 boosts the voltage to the 3.3V operating level for the PIC18F67J94. Resistor values used on the development board differ slightly from those listed below. Reference the schematic in [Appendix A: "PIC18F67J94 Development Board Schematic"](#) for actual resistor values used.

**FIGURE 3: 1.5V BATTERY AND MCP1640 BOOST CIRCUIT**

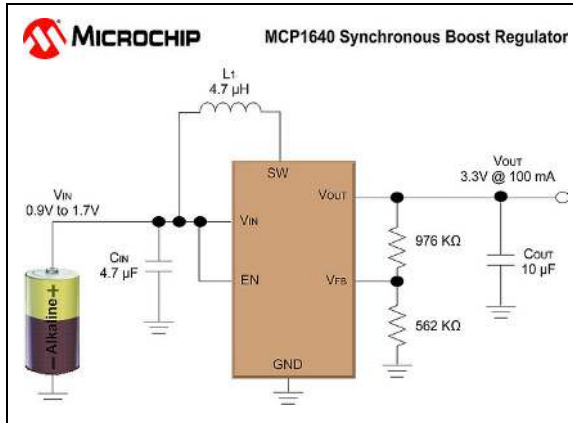

## DANCE GAME

This is intended to be a dynamic game that includes physical activity. If this type of activity has any risk of injury or damage to property, it can be operated as “sorcerer’s apprentice” where all participants remain safely seated and attempt to mirror the movements of a leader.

In order to demonstrate the features of the board, a game has been created wherein one baton (development board) establishes itself as a dance leader, and other boards are dance followers. Dance leader is selected by pressing the capacitive touch button. If a dance follower is able to closely mirror the movements of the dance leader, then their score will increase.

The wireless module has a range of approximately 30 feet with a fully charged battery.

## DANCE LEADER

After the capacitive touch button is pressed to become dance leader, an “L” will appear on the left-hand side of the display. The right-most digit will have segments move in a circular fashion. The circular motion of the right-most digit indicates that motion data is being broadcast to all followers within radio range.

## DANCE FOLLOWER

After one member of the group has been chosen to be dance leader, all other devices within radio range will become dance followers, and presses of the capacitive touch button will have no effect. Each time LED D1 changes, it indicates that motion data is being received from a dance leader. Activity on this LED indicates that the device is in Follower mode.

Full source code for the game has been provided. Developers that wish to modify the game (and reprogram through the HID bootloader) are free to do so.

## BATON OPERATION

The baton contains a 3-axis accelerometer with the axes oriented as shown below (Figure 4). The ‘Z’ axis comes out of the page.

**FIGURE 4: FRONT VIEW BATON WITH X, Y, Z AXES INDICATED**

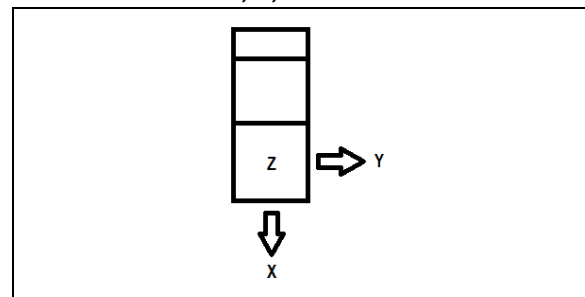

## ORIENTATION OF X, Y, Z AXES

The game should be started with the dance leader facing the group of dancers. Each player should have the baton in their right-hand, slightly in front of them, so that the LCD display is visible. The dance leader will be holding the baton so that he/she can see the “back” of the baton of the followers and vice versa. This scenario means that dance followers can mirror the movements of the dance leader, and the data from each axis can be compared directly, with the exception of the Y-axis, which will require a sign change. For the dance leader, the Y-axis comes out of the page, while for the Dance Followers, the Y-axis goes into the page. In order to compensate for this, the dance leader will switch the sign on its Y-axis data prior to transmission.

For instances where the follower is moving in unison with the group (not mirrored), this can be changed by commenting the sign change in main.c.

```
MiApp_WriteData(-DeltaAccel[1]);
// y (sign change on y-axis data) for
mirroring "dance leader"
```

# TB3094

```
//MiApp_WriteData(DeltaAccel[1]);  
// y (no sign change on y-axis data) for  
same movement as "dance leader"
```

**FIGURE 5: SIDE VIEW OF MULTIPLE DANCE BATONS WITH X, Y, Z AXES INDICATED**

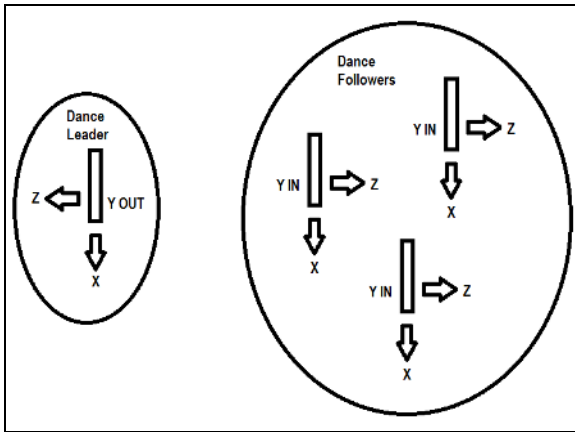

## START OF GAME PLAY

For start of Game Play, the dance leader will press the touch-sensitive button. This will establish the dance leader and the game starts one second later. The next button press will terminate the game and allow selection of a new dance leader.

## ACCELEROMETER SAMPLING

The accelerometer samples data at 100 Hz, and each sample from the dance leader is transmitted wirelessly to the other units in radio range. Receiving a packet which contains motion data will force the receiving unit into Follower mode. Units in Follower mode cannot request being dance leader.

## SCORE CALCULATION

Score is calculated by determining how well dance follower actions mirror that of the dance leader. The currently measured accelerations are compared against a circular history log of the dance leader. When events are closely correlated, the score will increase. If the dance leader is not moving, there will be no events registered, and the score will not increase. High scores are obtained through close correlation of dynamic movements.

Figure 6 shows an example of how score is increased. For measurements below the `EVENT_THRESHOLD`, there is no comparison made. If measurements are above the `EVENT_THRESHOLD` (in magnitude), then the measured delta in acceleration will be compared with the value in the circular event buffer. If the two values fall within a delta of each other, then the score will be increased, proportionally to how close the event lies in the event buffer to the current time.

**FIGURE 6: EXAMPLE OF HOW SCORE IS RELEASED**

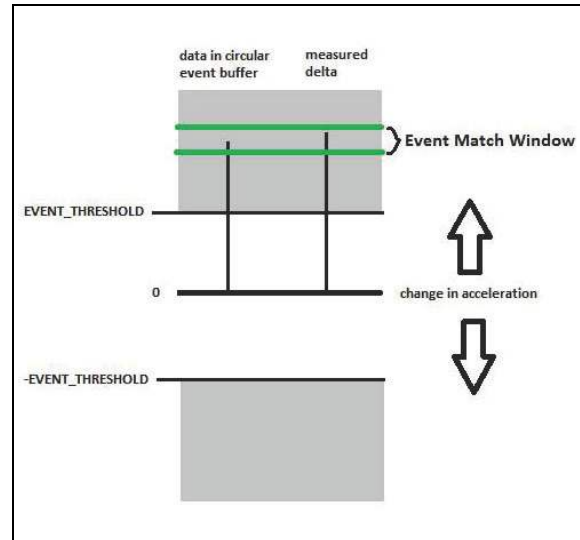
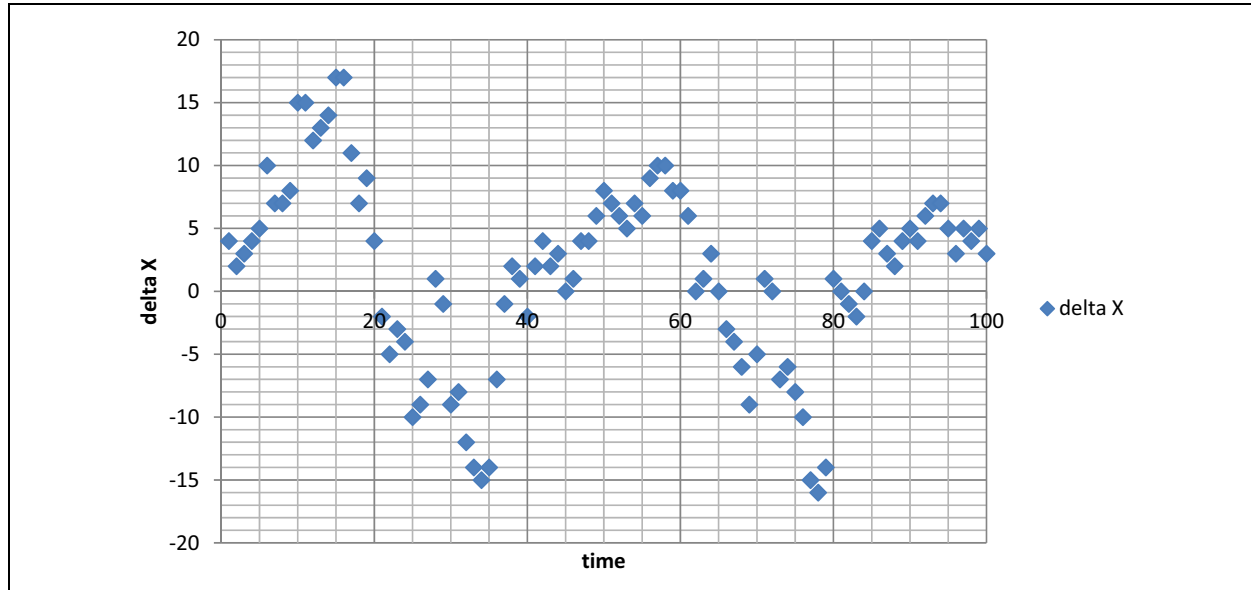

Figure 7 shows actual  $\Delta X$  acceleration data taken from the game. During periods of no movement, the value will lie close to zero. When the development board is moved along the X-axis, variations in  $\Delta X$  are produced. If current time = 80, data in the log prior to this will be compared with current measurements. To compare against prior events in the log, a countdown register is used. Once the countdown register falls below a certain value, the comparison stops. The countdown register is bit-shifted to produce the resultant increase in score. This causes movements that are closely correlated in time to result in larger increases in score. More intricate (and CPU intensive) methods are available for movement correlation, but this method works fairly well and leaves processor bandwidth for servicing wireless messages and taking care of other game-related tasks.

FIGURE 7: ACCELERATION DATA



## GAME WINNER

The participant with the highest score is the game winner, and will see the blue LEDs at the top of the development board flash. The participant with the lowest score will have the red LEDs (D3 and D4) light up momentarily.

## BATTERY LOW INDICATOR

If the AA battery drops below a certain voltage, then the message “-Lo-” will appear on the screen. If the battery is not replaced, the game may not work properly and wireless transmissions will have limited range. This level is set by `BATTERY_LOW_VALUE` in `main.c`.

## BOARD FEATURES

The development board contains the following features to enable development:

1. USB HID bootloader – the PIC18F67J94 microcontroller can be reprogrammed using a USB cable.
2. Multiple test points:
  - a) TP1 – DI signal connects to MRF24J40 and RA1
  - b) TP2 – SCK signal connects to accelerometer and RA6
  - c) TP3 – DO signal connects to MRF24J40 and RA0
  - d) TP4 – SDI signal connects to accelerometer and RA4
  - e) TP5 – CLK signal connects to MRF24J40 and RA3

- f) TP6 – SDO signal connects to accelerometer and RA5
  - g) TP7 – connects to RF5, and commonly used for UART ‘print’ data
  - h) TP8 – connects to RF6, and can be user-defined
  - i) TP9 – CS signal connects to accelerometer and RC7
  - j) TP10 – battery output voltage, connects to RG4
  - k) TP11 – Ground
3. ICSP™ programming connection is available on J2. The connector is not populated, but can be added to allow programming with supported Microchip programmers.

# TB3094

---

4. Error messages – Error messages (sent to LCD display) are provided to alert when unintended operation occurs. Unused error messages are available for development use.

**TABLE 2:**

<b>Error message</b>	<b>Cause</b>
0	Did not receive score header on response from follower
1	Time-out on score retrieval
2	Leader has not sent message in long time
3	Invalid radio channel has been selected
4	Message received with invalid header
5	Invalid leader value
6	No response from accelerometer at start-up
7	Unused
8	Unused
9	Unused

5. Multiple LEDs – LEDs are available to indicate status.
- D1 – flashes as wireless data is received.
  - D2 – unused
  - D3, D4 – light to indicate lowest score among group.

## TEST POINT FLEXIBILITY

Test Points 7 and 8 (TP7 and TP8) are currently configured as UART TX and RX. However, these pins can be reconfigured through PPS-Lite to have many other functions including interrupts, PWM outputs, timing capture inputs, etc. See Section 11-15 (PPS-Lite) of the PIC18F97J94 family data sheet for a list of available peripheral functions.





TABLE 3: BILL OF MATERIALS

Quantity	Designator	Description	Manufacturer 1	Manufacturer Part Number 1
1	B1	BHAA-3	MPD (Memory Protection Devices)	BHAA-3
6	C1, C2, C4, C5, C6, C7	Cap, Ceramic, 0.1uF, 50V X7R, Cap, Ceramic, 0.1uF, 50V, Cap, Ceramic, 0.1uF, 50V X7R, Cap, Ceramic, 0.1uF, 50V X7R, Cap, Ceramic, 0.1uF, 50V X7R, Cap, Ceramic, 0.1uF, 50V X7R	TDK Corporation	C1608X7R1H104M080AA
2	C3, C11	Cap, Ceramic, 10uF, 16V X5R	Taiyo Yuden	LMK212BJ106KG-T
1	C8	Cap, Ceramic, 10uF, 10V X5R 10%	TDK	C1608X5R1A106K
1	C9	Cap, Ceramic, 4.7uF, 10V, 20% X7R SMD	TDK	C2012X7R1A475M
4	D1, D2, D3, D4	LED, SMD, RED, 0603 package	Kingbright Corp	APT1608EC
4	D5, D6, D7, D8	LED, SMD, BLUE, 0603 package	Kingbright Corp	LB Q39G-L2N2-35-1
1	J1	CONN RECEPT MINI USB2.0 5POS	Hirose Electric Co Ltd	UX60A-MB-5ST
1	J2	Header, PICkit™ 2, 1X6 0.1sp	SAMTEC	TSW-106-07-F-S
1	L1	INDUCTOR MULTILAYER 4.7UH 0603	TDK Corporation	MLZ1608E4R7M
1	LCD1	LCD-S401M16KR	Lumex	LCD-S401M16KR
1	R1	Res, 4.7K 1/10W 1%	Stackpole Electronics Inc	RMCF0603FT4K70
8	R2, R3, R4, R5, R9, R10, R11, R12	Res, 330 Ohm, 1/10W 1%	Stackpole Electronics Inc	RMCF0603FT330R
1	R6	Res, 10K, 1/10W 1%	Stackpole Electronics Inc	RMCF0603FT10K0
1	R7	Res, 453K 1/10W 1%	Panasonic Electronic Components	ERJ-3EKF4533V
1	R8	Res, 309K 1/10W 1%	Stackpole Electronics Inc	RMCF0603FT309K
1	R13	Res, 56K 1/10W 1%	Panasonic Electronic Components	ERJ-3EKF5602V
1	R14	Res, 100K, 1/10W 1%	Stackpole Electronics Inc	RMCF0603FT100K
1	S1	Switch, Tact, PB MOM SMT, Series TL3302	E-Switch	TL3302AF180QJ
1	S2	Switch, Slide, SPDT, Rt Angle, SMT, Low Profile	TE Connectivity	MLL1200S
1	A	COSMOS 10 pcs black nylon hand wrist strap lanyard for camera		CELL-LG-WL-BKx10
1	U1	PIC18F67J94-X_PT	Microchip Technology	PIC18F67J94-I/PT
1	U2	IEEE 802.15.4 2.4 GHz RF Transceiver	Microchip Technology	MRF24J40MA
1	U3	IC ACCELEROMETER 3AXIS 16-LGA	STMicroelectronics	LIS331DL
1	U4	MCP1640T-I/CHY	Microchip Technology	MCP1640T-I/CHY



---

**Note the following details of the code protection feature on Microchip devices:**

- Microchip products meet the specification contained in their particular Microchip Data Sheet.
- Microchip believes that its family of products is one of the most secure families of its kind on the market today, when used in the intended manner and under normal conditions.
- There are dishonest and possibly illegal methods used to breach the code protection feature. All of these methods, to our knowledge, require using the Microchip products in a manner outside the operating specifications contained in Microchip's Data Sheets. Most likely, the person doing so is engaged in theft of intellectual property.
- Microchip is willing to work with the customer who is concerned about the integrity of their code.
- Neither Microchip nor any other semiconductor manufacturer can guarantee the security of their code. Code protection does not mean that we are guaranteeing the product as “unbreakable.”

Code protection is constantly evolving. We at Microchip are committed to continuously improving the code protection features of our products. Attempts to break Microchip's code protection feature may be a violation of the Digital Millennium Copyright Act. If such acts allow unauthorized access to your software or other copyrighted work, you may have a right to sue for relief under that Act.

---

Information contained in this publication regarding device applications and the like is provided only for your convenience and may be superseded by updates. It is your responsibility to ensure that your application meets with your specifications. MICROCHIP MAKES NO REPRESENTATIONS OR WARRANTIES OF ANY KIND WHETHER EXPRESS OR IMPLIED, WRITTEN OR ORAL, STATUTORY OR OTHERWISE, RELATED TO THE INFORMATION, INCLUDING BUT NOT LIMITED TO ITS CONDITION, QUALITY, PERFORMANCE, MERCHANTABILITY OR FITNESS FOR PURPOSE. Microchip disclaims all liability arising from this information and its use. Use of Microchip devices in life support and/or safety applications is entirely at the buyer's risk, and the buyer agrees to defend, indemnify and hold harmless Microchip from any and all damages, claims, suits, or expenses resulting from such use. No licenses are conveyed, implicitly or otherwise, under any Microchip intellectual property rights.

#### **Trademarks**

The Microchip name and logo, the Microchip logo, dsPIC, FlashFlex, KEELOQ, KEELOQ logo, MPLAB, PIC, PICmicro, PICSTART, PIC<sup>32</sup> logo, rPIC, SST, SST Logo, SuperFlash and UNI/O are registered trademarks of Microchip Technology Incorporated in the U.S.A. and other countries.

FilterLab, Hampshire, HI-TECH C, Linear Active Thermistor, MTP, SEEVAL and The Embedded Control Solutions Company are registered trademarks of Microchip Technology Incorporated in the U.S.A.

Silicon Storage Technology is a registered trademark of Microchip Technology Inc. in other countries.

Analog-for-the-Digital Age, Application Maestro, BodyCom, chipKIT, chipKIT logo, CodeGuard, dsPICDEM, dsPICDEM.net, dsPICworks, dsSPEAK, ECAN, ECONOMONITOR, FanSense, HI-TIDE, In-Circuit Serial Programming, ICSP, Mindi, MiWi, MPASM, MPF, MPLAB Certified logo, MPLIB, MPLINK, mTouch, Omniclient Code Generation, PICC, PICC-18, PICDEM, PICDEM.net, PICkit, PICtail, REAL ICE, rLAB, Select Mode, SQI, Serial Quad I/O, Total Endurance, TSHARC, UniWinDriver, WiperLock, ZENA and Z-Scale are trademarks of Microchip Technology Incorporated in the U.S.A. and other countries.

SQTP is a service mark of Microchip Technology Incorporated in the U.S.A.

GestIC and ULPP are registered trademarks of Microchip Technology Germany II GmbH & Co. KG, a subsidiary of Microchip Technology Inc., in other countries.

All other trademarks mentioned herein are property of their respective companies.

© 2013, Microchip Technology Incorporated, Printed in the U.S.A., All Rights Reserved.

 Printed on recycled paper.

ISBN: 9781620772485

**QUALITY MANAGEMENT SYSTEM**  
**CERTIFIED BY DNV**  
**== ISO/TS 16949 ==**

*Microchip received ISO/TS-16949:2009 certification for its worldwide headquarters, design and wafer fabrication facilities in Chandler and Tempe, Arizona; Gresham, Oregon and design centers in California and India. The Company's quality system processes and procedures are for its PIC® MCUs and dsPIC® DSCs, KEELOQ® code hopping devices, Serial EEPROMs, microperipherals, nonvolatile memory and analog products. In addition, Microchip's quality system for the design and manufacture of development systems is ISO 9001:2000 certified.*



# MICROCHIP

## Worldwide Sales and Service

### AMERICAS

**Corporate Office**  
2355 West Chandler Blvd.  
Chandler, AZ 85224-6199  
Tel: 480-792-7200  
Fax: 480-792-7277  
Technical Support:  
<http://www.microchip.com/support>  
Web Address:  
[www.microchip.com](http://www.microchip.com)

**Atlanta**  
Duluth, GA  
Tel: 678-957-9614  
Fax: 678-957-1455

**Boston**  
Westborough, MA  
Tel: 774-760-0087  
Fax: 774-760-0088

**Chicago**  
Itasca, IL  
Tel: 630-285-0071  
Fax: 630-285-0075

**Cleveland**  
Independence, OH  
Tel: 216-447-0464  
Fax: 216-447-0643

**Dallas**  
Addison, TX  
Tel: 972-818-7423  
Fax: 972-818-2924

**Detroit**  
Farmington Hills, MI  
Tel: 248-538-2250  
Fax: 248-538-2260

**Indianapolis**  
Noblesville, IN  
Tel: 317-773-8323  
Fax: 317-773-5453

**Los Angeles**  
Mission Viejo, CA  
Tel: 949-462-9523  
Fax: 949-462-9608

**Santa Clara**  
Santa Clara, CA  
Tel: 408-961-6444  
Fax: 408-961-6445

**Toronto**  
Mississauga, Ontario,  
Canada  
Tel: 905-673-0699  
Fax: 905-673-6509

### ASIA/PACIFIC

**Asia Pacific Office**  
Suites 3707-14, 37th Floor  
Tower 6, The Gateway  
Harbour City, Kowloon  
Hong Kong  
Tel: 852-2401-1200  
Fax: 852-2401-3431

**Australia - Sydney**  
Tel: 61-2-9868-6733  
Fax: 61-2-9868-6755

**China - Beijing**  
Tel: 86-10-8569-7000  
Fax: 86-10-8528-2104

**China - Chengdu**  
Tel: 86-28-8665-5511  
Fax: 86-28-8665-7889

**China - Chongqing**  
Tel: 86-23-8980-9588  
Fax: 86-23-8980-9500

**China - Hangzhou**  
Tel: 86-571-2819-3187  
Fax: 86-571-2819-3189

**China - Hong Kong SAR**  
Tel: 852-2943-5100  
Fax: 852-2401-3431

**China - Nanjing**  
Tel: 86-25-8473-2460  
Fax: 86-25-8473-2470

**China - Qingdao**  
Tel: 86-532-8502-7355  
Fax: 86-532-8502-7205

**China - Shanghai**  
Tel: 86-21-5407-5533  
Fax: 86-21-5407-5066

**China - Shenyang**  
Tel: 86-24-2334-2829  
Fax: 86-24-2334-2393

**China - Shenzhen**  
Tel: 86-755-8864-2200  
Fax: 86-755-8203-1760

**China - Wuhan**  
Tel: 86-27-5980-5300  
Fax: 86-27-5980-5118

**China - Xian**  
Tel: 86-29-8833-7252  
Fax: 86-29-8833-7256

**China - Xiamen**  
Tel: 86-592-2388138  
Fax: 86-592-2388130

**China - Zhuhai**  
Tel: 86-756-3210040  
Fax: 86-756-3210049

### ASIA/PACIFIC

**India - Bangalore**  
Tel: 91-80-3090-4444  
Fax: 91-80-3090-4123

**India - New Delhi**  
Tel: 91-11-4160-8631  
Fax: 91-11-4160-8632

**India - Pune**  
Tel: 91-20-2566-1512  
Fax: 91-20-2566-1513

**Japan - Osaka**  
Tel: 81-6-6152-7160  
Fax: 81-6-6152-9310

**Japan - Tokyo**  
Tel: 81-3-6880-3770  
Fax: 81-3-6880-3771

**Korea - Daegu**  
Tel: 82-53-744-4301  
Fax: 82-53-744-4302

**Korea - Seoul**  
Tel: 82-2-554-7200  
Fax: 82-2-558-5932 or  
82-2-558-5934

**Malaysia - Kuala Lumpur**  
Tel: 60-3-6201-9857  
Fax: 60-3-6201-9859

**Malaysia - Penang**  
Tel: 60-4-227-8870  
Fax: 60-4-227-4068

**Philippines - Manila**  
Tel: 63-2-634-9065  
Fax: 63-2-634-9069

**Singapore**  
Tel: 65-6334-8870  
Fax: 65-6334-8850

**Taiwan - Hsin Chu**  
Tel: 886-3-5778-366  
Fax: 886-3-5770-955

**Taiwan - Kaohsiung**  
Tel: 886-7-213-7828  
Fax: 886-7-330-9305

**Taiwan - Taipei**  
Tel: 886-2-2508-8600  
Fax: 886-2-2508-0102

**Thailand - Bangkok**  
Tel: 66-2-694-1351  
Fax: 66-2-694-1350

### EUROPE

**Austria - Wels**  
Tel: 43-7242-2244-39  
Fax: 43-7242-2244-393

**Denmark - Copenhagen**  
Tel: 45-4450-2828  
Fax: 45-4485-2829

**France - Paris**  
Tel: 33-1-69-53-63-20  
Fax: 33-1-69-30-90-79

**Germany - Munich**  
Tel: 49-89-627-144-0  
Fax: 49-89-627-144-44

**Italy - Milan**  
Tel: 39-0331-742611  
Fax: 39-0331-466781

**Netherlands - Drunen**  
Tel: 31-416-690399  
Fax: 31-416-690340

**Spain - Madrid**  
Tel: 34-91-708-08-90  
Fax: 34-91-708-08-91

**UK - Wokingham**  
Tel: 44-118-921-5869  
Fax: 44-118-921-5820

11/29/12