

order number	lens name	f-stop
0009-190-000-40	Macro-CCD-Lens -0.3x 3.5	3.5
0009-190-000-41	Macro-CCD-Lens -0.3x 5.6	5.6
0009-190-000-42	Macro-CCD-Lens -0.3x 8	8

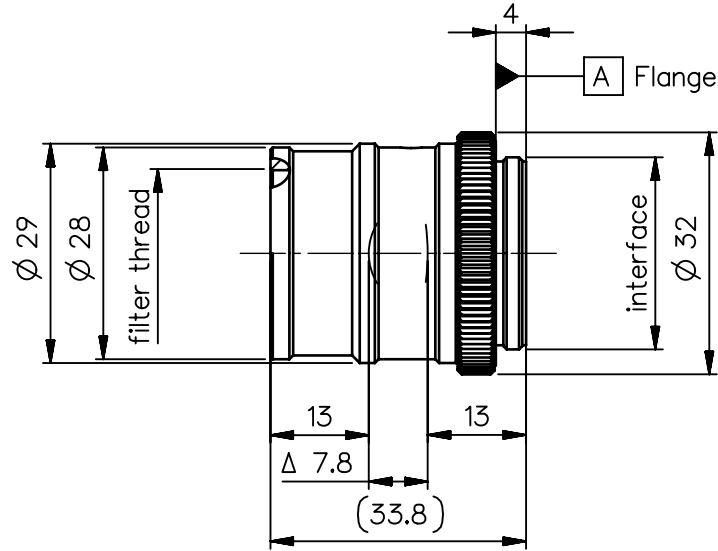

Specification		ON	
image circle max. (mm)	11	working distance (mm)	90
focal length f' (mm)	24.2	interface	C-mount
magnification β' [range]	-0.3	filter thread	M22.5 x0.5
spectral range λ (nm)	400 - 750	weight (g)	40
schematic diagram		*) in air	
		design includes CCD cover glass: no	
		SF (mm)	-22.9
		S'F' (mm) *)	19.4
		HH' (mm) *)	1.7
		SH (mm)	-1.3
		S'H' (mm) *)	-4.8
		S'EnP (mm)	
		S'Exp (mm) *)	
		f-stop	
		\varnothing EnP	
		\varnothing Exp	

NX PROTECTIVE NOTE "DIN ISO 16016" TO BE OBSERVED	EU-D	AL-T1A	US-D	US-ML	not export controlled	
	REV	ECC	DATE	APPROVED	PDM Status Freigabe	
	a	neu			-	
	b	08-0281	24.11.08	Stroz	SCALE 1:1	
	c	11-0358	20.07.11	Kuehne	MATERIAL	
d	14-0184	21.08.14	Schiffel	BASIC TOLERANCING PRINCIPLE	TITLE	
e	17-0915	20.03.18	Denk		Macro-CCD-Lens 0.3x	
				FIRST ISSUE	DATE	NAME
				21.08.14	21.08.14	Schifferer
				CHKD	21.08.14	Stauder
				DRAWING NO.		SHEET 1
				0009-190-100-00-0001e		OF 1
				REPLACES		

ALL DIMENSIONS ARE IN MM AND INCLUDE SURFACE TREATMENT

