

MATERIAL NO. LOOSE PIECE	ENG. NO.	MATERIAL NO. TAPE MOUNTED	ENG. NO.	STUD SIZE	±.003 "S"	"W" MAX.	"C" MIN.	"L" MAX.
190690091	BB-118-10	-----	-----	10	.198 (5.03)			
190690092	BB-118-14	190690133	BB-118-14T	14	.265 (6.73)	.544 (13.82)	.535 (13.59)	1.010 (25.65)
190690093	BB-118-38	190690094	BB-118-38T	38 (A1)	.390 (9.91)			
190690096	BB-118-56	190690097	BB-118-56T	56 (A1)	.328 (8.33)			
190690098	BB-123-02	190690134	BB-123-02T	2	.094 (2.39)			
190690099	BB-123-04	190690100	BB-123-04T	4	.119 (3.02)	.260 (6.60)	.209 (5.31)	.560 (14.22)
190690101	BB-123-06	190690102	BB-123-06T	6	.146 (3.71)			
190690103	BB-123-08	190690104	BB-123-08T	8	.173 (4.39)			
190690105	BB-125-10	190690106	BB-125-10T	10	.198 (5.03)	.477 (12.11)	.388 (9.86)	.837 (21.26)
190690107	BB-125-14	190690108	BB-125-14T	14	.265 (6.73)			
190690109	BB-125-56	190690110	BB-125-56T	56	.328 (8.33)			
190690112	BB-137-06	190690113	BB-137-06T	6	.146 (3.71)			
190690114	BB-137-08	190690115	BB-137-08T	8	.173 (4.39)	.322 (8.18)	.275 (6.98)	.645 (16.38)
190690116	BB-137-10	190690117	BB-137-10T	10	.198 (5.03)			
190690119	BB-139-04	-----	-----	4	.119 (3.02)	.352 (8.94)	.305 (7.75)	.696 (17.68)
190690120	BB-139-06	190690138	BB-139-06T	6	.146 (3.71)			
190690121	BB-139-08	190690122	BB-139-08T	8	.173 (4.39)			
190690123	BB-139-10	190690124	BB-139-10T	10	.198 (5.03)			

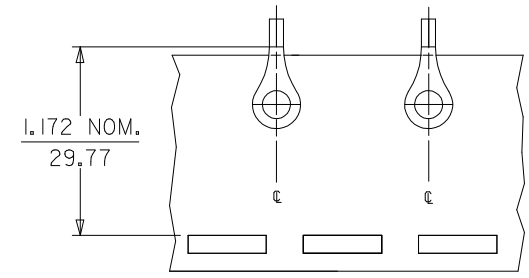

ENG. NO.
BB-118-** ONLY

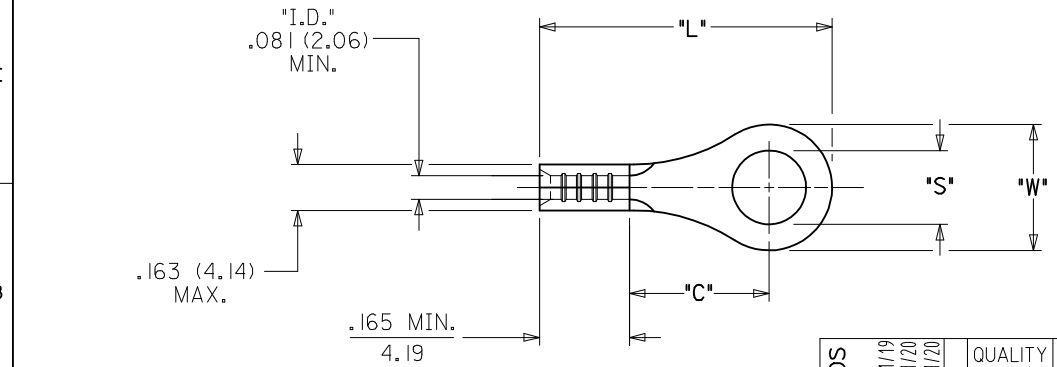
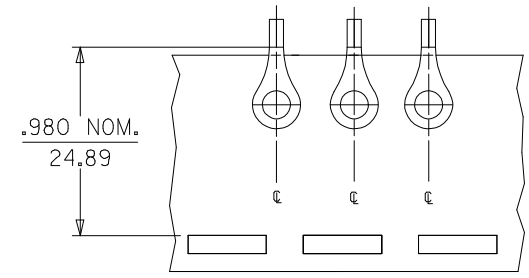

- NOTE(S):**
- MATERIAL: COPPER (.031/0.79 THICK)
PLATING: ELECTROPLATE TIN
 - WIRE SIZE: 16-14 AWG²
1.0 - 2.5 MM
 - (A1) PARTS ARE ROHS COMPLIANT.

SALES DRAWING

FIX SWAPPED STUDS EC NO: WNA2009-0338 DRW: HETHRODAHL 2008/11/19 CHKD: JMACNEIL 2008/11/20 APPR: JMACNEIL 2008/11/20 A1	QUALITY SYMBOLS	GENERAL TOLERANCES (UNLESS SPECIFIED)	DIMENSION STYLE	SCALE	DESIGN UNITS	THIRD ANGLE PROJECTION
	▼=0 ▽=0	mm INCH	IN/MM	---	INCH	
		4 PLACES ± --- ± --- 3 PLACES ± --- ± .005 2 PLACES ± 0.13 ± .01 1 PLACE ± 0.25 ± --- ANGULAR ± ---°	DRAWN BY DATE DLM 2003/02/21 CHECKED BY DATE SB 2003/02/21 APPROVED BY DATE RWD 2003/02/21	TITLE	RING TONGUE TERMINAL KRIMPTITE 16-14 AWG	
		DRAFT WHERE APPLICABLE MUST REMAIN WITHIN DIMENSIONS	MATERIAL NO. SEE CHART SIZE B	DOCUMENT NO. SD-19069-013	MOLEX INCORPORATED SHEET NO. 1 OF 1	