



40DDW_1.5 Series

40W - Single/Dual Output - Wide Input - Isolated & Regulated
DIP DC-DC Converter

DC-DC Converter

40 Watt

- ⊕ High efficiency up to 91%
- ⊕ 2:1 wide input voltage range
- ⊕ Isolation voltage 1500VDC
- ⊕ Six-sided metal shield
- ⊕ Short circuit protection (SCP) (automatic recovery)
- ⊕ Operating temperature: -40°C to +85°C
- ⊕ Over temperature protection
- ⊕ Industry standard pinout
- ⊕ Under voltage lockout

The 40DDW_1.5 series offers 40W of output, wide input voltage of 9-18VDC, 18-36VDC, 36-75VDC and features 1500VDC isolation, six-sided metal shield over current and short circuit protection.

All models are particularly suited to tele-communications, industrial, test equipments power etc.



Common specifications	
Cooling:	Free air convection
Short circuit protection:	Continuous, auto-recovery
Operation temperature range:	-40°C~+85°C
Storage temperature range:	-55°C~+125°C
Case temperature:	105°C
Lead temperature range:	265°C MAX, 1.5mm from case for 10 sec
Switching frequency (PWM mode):	300kHz TYP
Humidity:	non-condensing, 95% MAX
Case material:	Metal
Potting material:	Epoxy (UL94V-0 rated)
MTBF (MIL-HDBK-217F @25°C)*:	>150,000 hours
Weight:	70g

* BELLCORE TR-NWT-000332. Case I: 50% Stress, Temperature at 40°C. (Ground fixed and controlled environment)

Input specifications						
Item	Test condition	Min	Typ	Max	Units	
Start-up voltage / under voltage lockout	• 12Vin		9/8		VDC	
	• 24Vin		17.8/15.8		VDC	
	• 48Vin		36/33		VDC	
Surge voltage	100ms max.					
	• 12Vin			25	V	
	• 24Vin			50	V	
	• 48Vin			100	V	
Conducted noise*	EN 55022 level A, FCC part 15, level A with external capacitor					
Filter	Pi type					

* The 40DDW series can meet EN55022 Class A with parallel an external capacitor to the input pins. Recommend:
12Vin: 10µF/25V X7R 1812 MLCC
24Vin: 4.7µF/50V X7R 1812 MLCC.
48Vin: 2.2µF/100V X7R 1812 MLCC.

Isolation specifications						
Item	Test condition	Min	Typ	Max	Units	
Isolation voltage	Input/Output, tested for 1 minute and 1mA max			1500	VDC	
Isolation resistance	Test at 500VDC	1000			MΩ	
Isolation capacitance	Input/Output, 100KHz/0.1V			2500	pF	

Output specifications						
Item	Test condition	Min	Typ	Max	Units	
Voltage tolerance	Full load @Vin(nom.)			±2	%	
Output voltage adjustment	only for single output models and symmetric dual output models			±10	%	
Line regulation	Vin min to Vin max, F.L			±0.5	%	
Load regulation	10% to 100% load	• Single		±0.5	%	
		• Dual (balance load)		±1	%	
Cross regulation	25% / 100% (Dual output)			±5	%	
Ripple and noise ¹⁾	20MHz Bandwidth		85	100	mV	
Start-up time	nominal Vin and constant resistive load		25		ms	
Transient response setting time	25% load step change		300		µs	
Over load protection	Input voltage range			150	%Io	
Over voltage protection	• 3.3VDC • 5VDC • 12VDC • 15VDC		3.9		V	
			6.2		V	
			15		V	
			18		V	
Remote ON/OFF ²⁾	• ON • OFF • Off idle current	Open				
		Short to -Vin		2.5	mA	
External trim adj. range				±10	%	

- 1) Test ripple and noise by "parallel cable" method. Typical value at nominal input voltage and no load.
- 2) The ON/OFF control pin voltage is referenced to -Input. (Leave open if not used.)

Model selection:

WCTV_xxyyN##
W= Watt; **C**=Case; **T**= Type; **V**= Voltage Variation (omitted ± 10%);
xx= Vin; **yy**= Vout; **N**= Numbers of Output; **##**= Isolation (kVDC)

Example:

40DDW_2415S1.5
40= 40Watt; **D**= DIP; **D**= series; **W**= wide input (2:1) **18-36Vin**;
15Vout; **S**= single output; **1.5**= 1500VDC

Note:

1. Input voltage can't exceed this value, or will cause the permanent damage.
2. The load shouldn't be less than 5%, otherwise ripple will increase dramatically.
3. Max. Capacitive Load is tested on Vin-nominal and full load.
4. All specifications measured at Ta=25°C, humidity<75%, nominal input voltage and rated output load unless otherwise specified.
5. In this datasheet, all the test methods of indications are based on corporate standards.
6. Only typical models listed, other models may be different, please contact our technical person for more details.
7. Specifications subject to change without notice.

40DDW_1.5 Series

40W - Single/Dual Output - Wide Input - Isolated & Regulated
DIP DC-DC Converter

Part Number	Input Voltage Range [VDC]	Input current [mA, typ]		Output Voltage [VDC]	Output Current [mA]	Efficiency [%, Typ.]	Capacitive load* [μF, max.]
		no load	full load				
40DDW_1203S1.5	9-18	120	3125	3.3	10000	88	16000
40DDW_1205S1.5	9-18	130	3703	5	8000	90	10000
40DDW_1212S1.5	9-18	50	3750	12	3300	88	2000
40DDW_1215S1.5	9-18	50	3721	15	2650	89	1200
40DDW_2403S1.5	18-36	70	1544	3.3	10000	89	16000
40DDW_2405S1.5	18-36	80	1831	5	8000	91	10000
40DDW_2412S1.5	18-36	30	1833	12	3300	90	2000
40DDW_2415S1.5	18-36	30	1840	15	2650	90	1200
40DDW_4803S1.5	36-75	40	763	3.3	10000	90	16000
40DDW_4805S1.5	36-75	50	915	5	8000	91	10000
40DDW_4812S1.5	36-75	30	916	12	3300	90	2000
40DDW_4815S1.5	36-75	30	920	15	2650	90	1200
40DDW_1212D1.5	9-18	60	3752	±12	±1670	89	±1000
40DDW_1215D1.5	9-18	60	3764	±15	±1340	89	±680
40DDW_2412D1.5	18-36	30	1855	±12	±1670	90	±1000
40DDW_2415D1.5	18-36	30	1861	±15	±1340	90	±680
40DDW_4812D1.5	36-75	30	927	±12	±1670	90	±1000
40DDW_4815D1.5	36-75	30	930	±15	±1340	90	±680

* Test by normal Vin and constant resistive load.

Typical characteristics

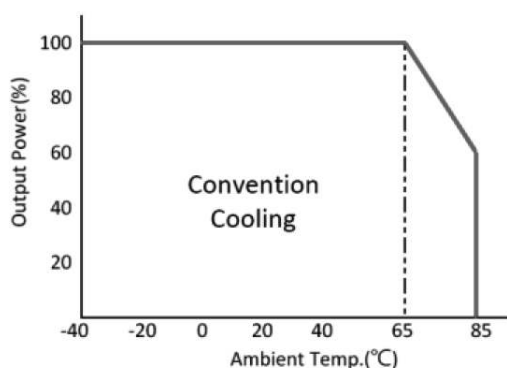

Output voltage adjustment

Output can be externally trimmed by using the method shown below.
() for dual output trim.

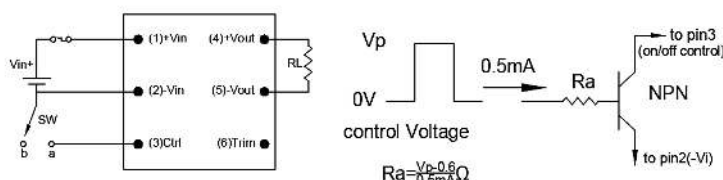
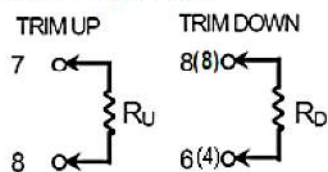

When pin3 short to pin2, D/D ON => OFF
When pin3 leave open, D/D => ON

Suggest Circuit:

40DDW_1.5 Series

40W - Single/Dual Output - Wide Input - Isolated & Regulated
DIP DC-DC Converter

EMC considerations

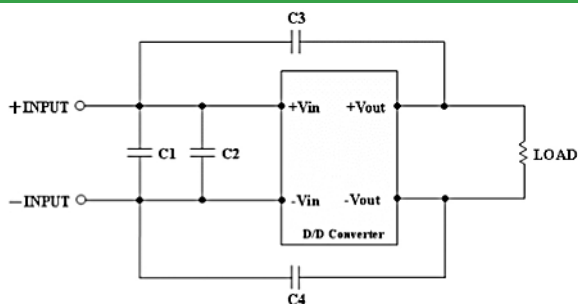

Suggested Schematic to comply with Conducted Noise according to EN55022 Class A

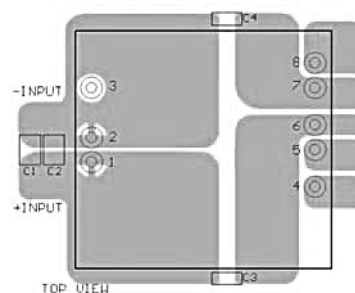

Recommended Layout with input Filter

Following components are needed to comply with EN55022 Class A conducted noise:

40DDW_12xx

Component	Value	Voltage	Reference
C1, C2	10 μ F	25V	1812 MLCC
C3, C4	1000pF	2KV	1206 MLCC

40DDW_24xx

Component	Value	Voltage	Reference
C1, C2	4.7 μ F	50V	1812 MLCC
C3, C4	1000pF	2KV	1206 MLCC

40DDW_48xx

Component	Value	Voltage	Reference
C1, C2	2.2 μ F	100V	1812 MLCC
C3, C4	1000pF	2KV	1206 MLCC

Mechanical dimensions

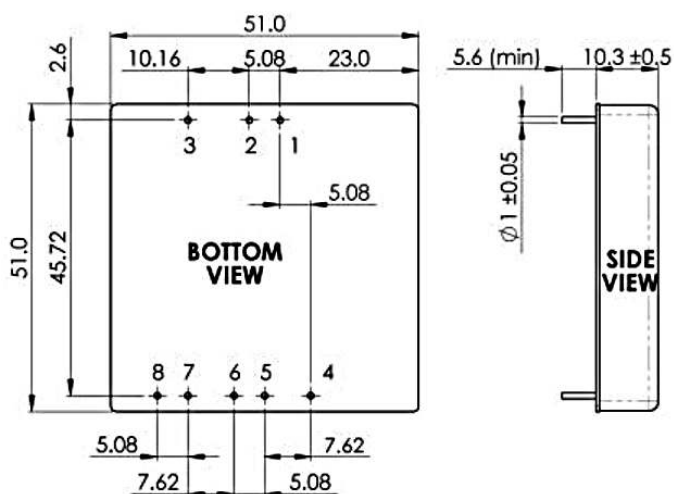

Note:

Unit: mm[inch]
Pin diameter tolerances: ± 0.05 mm [± 0.002 inch]
General tolerances: ± 0.25 mm [± 0.010 inch]

PIN connection								
PIN	1	2	3	4	5	6	7	8
Single	+Vin	-Vin	Remote On/Off	-Sense	+Sense	+Vout	-Vout	Trim
Dual	+Vin	-Vin	Remote On/Off	+Vout	COM	COM	-Vout	Trim