

SECTION A-A

SECTION B-B

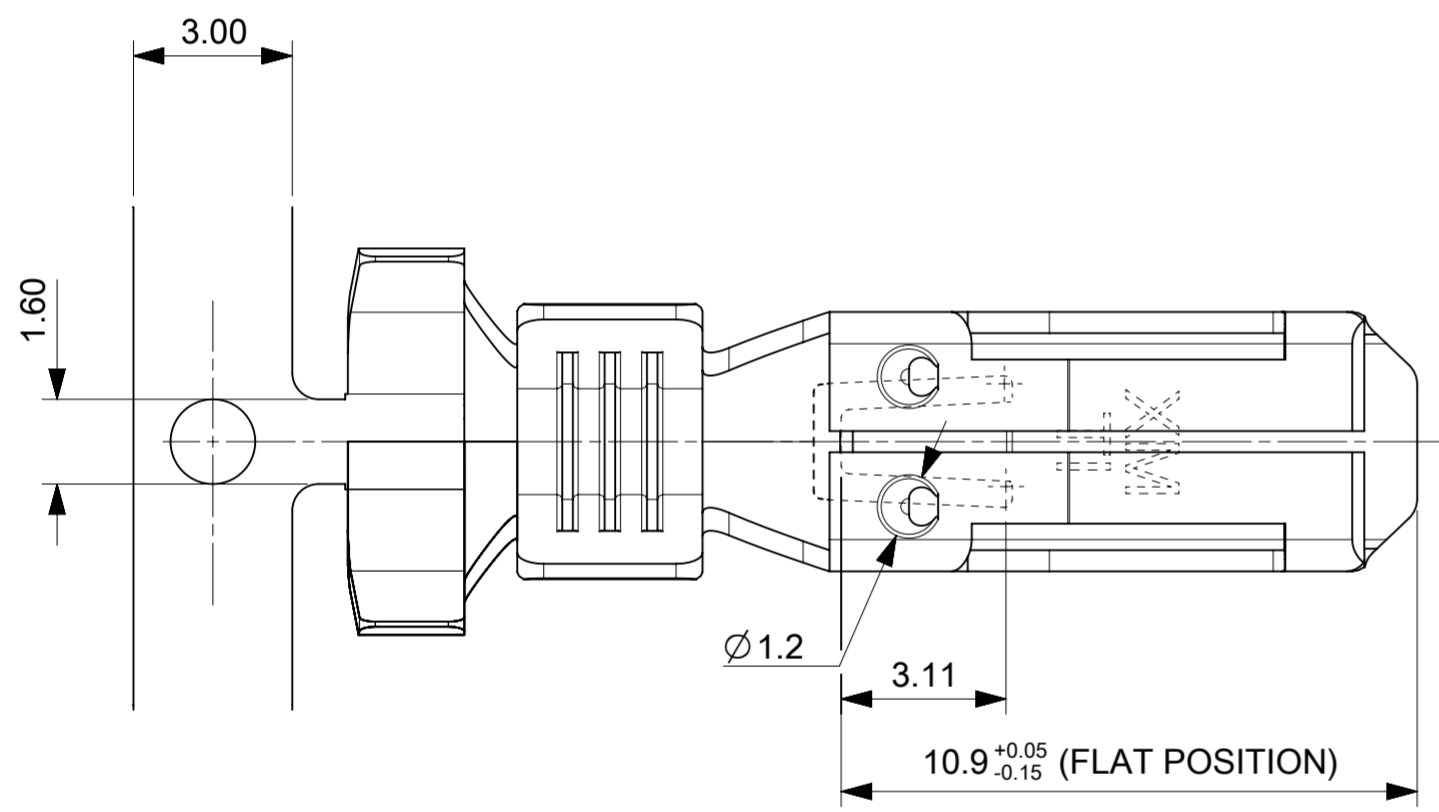

P/N	PLATING	MATERIAL	WIRE RANGE	INS. RANGE	DIMENSION				
					A	B	C	D	E
94518-0100	PLAIN	BRASS	0.5 - 1.0	2.2 - 2.8	4.5	4.5	3.0	3.0	/
94518-0101	TIN								
94518-0200	PLAIN	BRASS	1.0 - 2.5 FOR SINGLE DOUBLE CABLES	2.6 - 3.8	5.5	5.5	4.1	4.3	/
94518-0201	TIN								
94518-0400	PLAIN	BRASS	1.5 - 3.0 FOR DOUBLE CABLES	-	7.3	5.1	5.2	4.0	1.8
94518-0401	TIN								
94518-0300	PLAIN	BRASS	4.0	3.4 - 3.7	5.5	5.5	5.0	5.1	/
94518-0301	TIN								

DIRECTION OF UNREELING

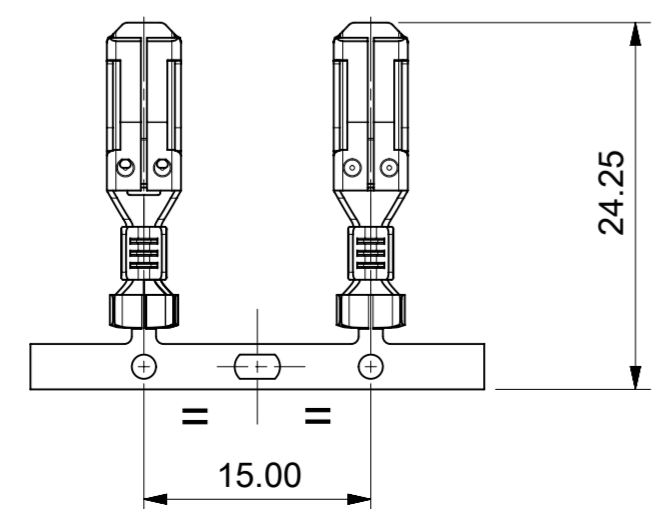
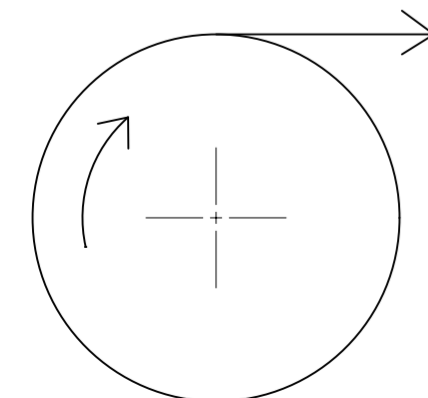

PACKAGING: REFER 945180001-PK  
 STD. DESCRIPTION: HNF TERM (material-plating-wire gauge)

FUNCTIONAL SYMBOLS $F_A = 0$ $F_C = 0$ $F_P = 0$ DIVISIONAL SYMBOLS	THIS DRAWING CONTAINS INFORMATION THAT IS PROPRIETARY TO MOLEX ELECTRONIC TECHNOLOGIES, LLC AND SHOULD NOT BE USED WITHOUT WRITTEN PERMISSION		CURRENT REV DESC: REMOVED PN: 94518-0120,-0121,-0220,-0221		
	DIMENSION UNITS	SCALE	EC NO: 657968		
	mm	7:1	DRWN: SCV 2021/03/09		
	GENERAL TOLERANCES (UNLESS SPECIFIED)		CHK'D: MBN02 2021/03/15		
ANGULAR TOL ± 2.0°		APPR: SDEVITT 2021/03/22		PRODUCT CUSTOMER DRAWING	
4 PLACES ±		INITIAL REVISION:		DOCUMENT NUMBER	
3 PLACES ±		DRWN: AKABADI 2021/01/07		945180001	
2 PLACES ± 0.1		APPR: SDEVITT 2021/02/25		DOC TYPE   DOC PART   REVISION	
1 PLACE ± 0.2				PSD   000   A1	
0 PLACES ±					
DRAFT WHERE APPLICABLE MUST REMAIN WITHIN DIMENSIONS		THIRD ANGLE PROJECTION	DRAWING	SERIES	MATERIAL NUMBER
			A2-SIZE	94518	SEE TABLE
					CUSTOMER
					GENERAL MARKET
					SHEET NUMBER
					1 OF 1

10 9 8 7 6 5 4 3 2 1

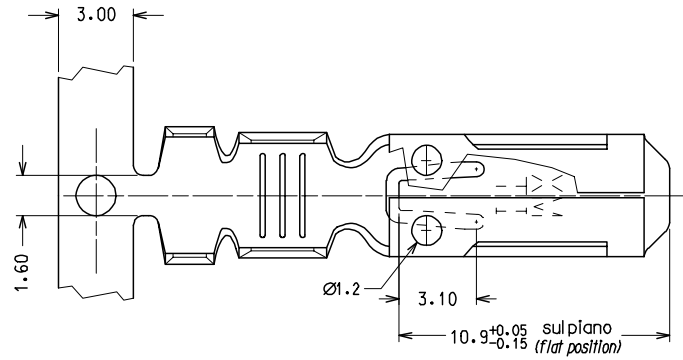
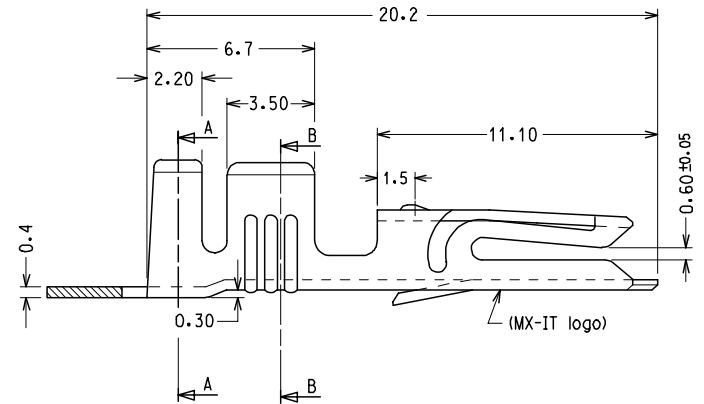
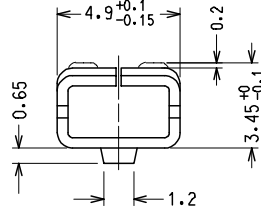
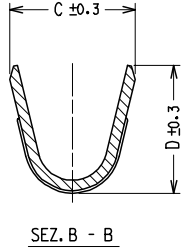
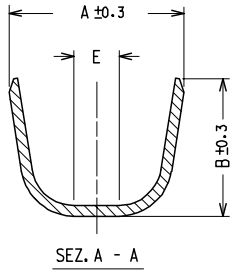

CODICE P/N	FINITURA PLATING	MATERIALE MATERIAL	SEZ. RAME WIRE RANGE	Ø ISOLANTE INS. RANGE	DIMENSIONI					PZ./BOBINA PCS/REEL
					A	B	C	D	E	
94518 - 0100	GREGGIO/ PLAIN	OTTONE BRASS	0.5 - 1.0	2.2 - 2.8	4.5	4.5	3.0	3.0	/	3000
94518 - 0101	STAGNATO/ TIN									
94518 - 0120	GREGGIO/ PLAIN	BRONZO FOSF. PHOSP.BRONZE	1.0 - 2.5	2.6 - 3.8	5.5	5.5	4.1	4.3	/	2500
94518 - 0121	STAGNATO/ TIN									
94518 - 0200	GREGGIO/ PLAIN	OTTONE BRASS	1.0 - 2.5	2.6 - 3.8	5.5	5.5	4.1	4.3	/	2500
94518 - 0201	STAGNATO/ TIN									
94518 - 0220	GREGGIO/ PLAIN	BRONZO FOSF. PHOSP.BRONZE	PER CAVI SINGOLI E DOPPI (VEDERE FOGLIO 2/2)	1.5 - 3.0	7.3	5.1	5.2	4.0	1.8	2500
94518 - 0221	STAGNATO/ TIN									
94518 - 0400	GREGGIO/ PLAIN	OTTONE BRASS	PER CAVI DOPPI (VEDERE FOGLIO 2/2)	3.4 - 3.7	5.5	5.5	5.0	5.1	/	2500
94518 - 0401	STAGNATO/ TIN									
94518 - 0300	GREGGIO/ PLAIN	OTTONE BRASS	4.0	3.4 - 3.7	5.5	5.5	5.0	5.1	/	2500
94518 - 0301	STAGNATO/ TIN									

CONFEZIONE:  
N° 5 bobine con carta intermedia per box.

PACKING:  
N° 5 reels with Interleaf paper/box

Std. Descr.: HNF TERM (material-plating-wire range)

SENSO DI SVOLGIMENTO PER MINIAPPLICATORE  
DIRECTION OFF REEL

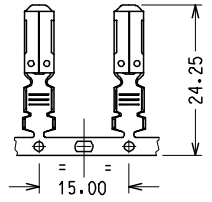
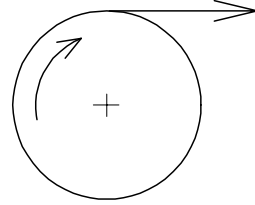

EC NO: Z2005-0129	2005/03/31	2005/03/31	2005/04/01
DRAWN:FGOTTARD	CHKD:RSANDANO	APP:GZUIN	DESCRIPTION

QUALITY SYMBOLS	▽=0	▽=0
-----------------	-----	-----

GENERAL TOLERANCES (UNLESS SPECIFIED)	
	mm INCH
4 PLACES	± --- ± ---
3 PLACES	± --- ± ---
2 PLACES	± 0.10 ± ---
1 PLACE	± 0.2 ± ---
ANGULAR ± 2 °	
DRAFT WHERE APPLICABLE MUST REMAIN WITHIN DIMENSIONS	

DIMENSION STYLE MM ONLY	
DRAWN BY	DATE
FGOTTARD	1992/10/01
CHECKED BY	DATE
APPROVED BY	DATE
MPREVIAT	1992/10/01
MATERIAL NO.	DOCUMENT NO.
SEE CHART	SD-94518-005

SCALE 5:1	DESIGN UNITS METRIC	FIRST ANGLE PROJECTION
TITLE HNF FEMALE TERMINAL FOR 6.3 X 0.8 TABS		
MOLEX INCORPORATED		
DOCUMENT NO. SD-94518-005		SHEET NO. 1 OF 1
THIS DRAWING CONTAINS INFORMATION THAT IS PROPRIETARY TO MOLEX INCORPORATED AND SHOULD NOT BE USED WITHOUT WRITTEN PERMISSION		

9 8 7 6 5 4 3 2 1