

## Description

The MK5818 generates a low EMI output clock and a reference clock from a clock or crystal input. The part is designed to lower EMI through the application of spreading a clock. Using IDT's proprietary mix of analog and digital Phase Locked Loop (PLL) technology, the device spreads the frequency spectrum of the output, reducing the frequency amplitude peaks by several dB depending on spread range. The MK5818 offers a range of down spread from a high speed clock or crystal input. The MK5818 generates one modulated (SSCLK) and unmodulated (REFCLK) clock and is compatible with Cypress CY25818. The modulated clock is controlled by the select pin, and the unmodulated clock has the same frequency as the input clock or crystal.

## Features

- Packaged in 8-pin SOIC
- Input frequency range 8 to 16 MHz
- Provides modulated and unmodulated clocks
- Accepts a clock or crystal input
- Provides down spread modulation
- Provides power down function
- Reduce electromagnetic interference (EMI) by 8 to 16 db
- Operating voltage of 3.3 V
- Advanced, low-power CMOS process
- Pb (lead) free package, RoHS compliant

## Block Diagram

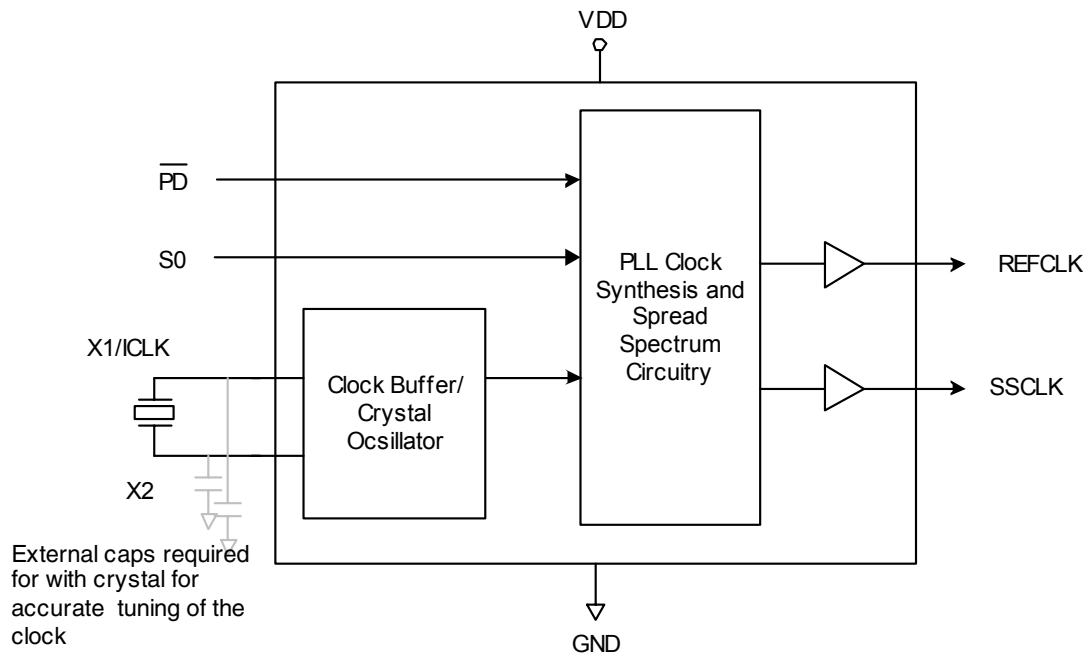

## Pin Assignment

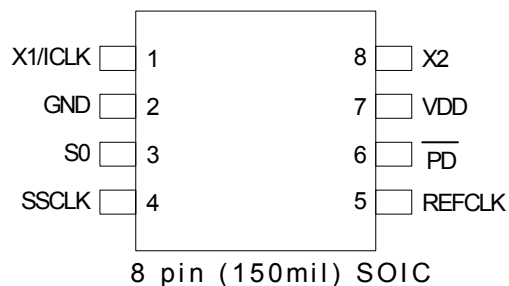

## Spread Percentage Select Table

S0	Spread Direction	Spread Percentage (%)
0	Down	-1.7
1	Down	-2.3
M	Down	-0.5

0 = connect to GND

M= unconnected

1 = connect directly to VDD

## Pin Descriptions

Pin Number	Pin Name	Pin Type	Pin Description
1	X1/ICLK	Input	Connect to 8-16 MHz crystal or clock.
2	GND	Power	Connect to ground.
3	S0	Input	Select spread percentage per table above. Tri-level input. Default = M.
4	SSCLK	Output	Spread spectrum clock output per table above.
5	REFCLK	Output	Unmodulated reference clock output.
6	$\overline{\text{PD}}$	Input	Power down tri-state. This pin powers down entire chip and tri-state the outputs when low. Internal pull-up.
7	VDD	Power	Connect to 3.3 V.
8	X2	Input	Connect to 8-16 MHz crystal or leave unconnected.

## External Components

The MK5818 requires a minimum number of external components for proper operation.

### Decoupling Capacitor

A decoupling capacitor of 0.01 $\mu$ F must be connected between VDD and GND, as close to these pins as possible. For optimum device performance, the decoupling capacitor should be mounted on the component side of the PCB. Avoid the use of vias in the decoupling circuit.

### PCB Layout Recommendations

For optimum device performance and lowest output phase noise, the following guidelines should be observed.

1) The 0.01 $\mu$ F decoupling capacitor should be mounted on the component side of the board as close to the VDD pin as possible. No vias should be used between the decoupling capacitor and VDD pin. The PCB trace to VDD pin should be kept as short as possible, as should the PCB trace to the ground via.

2) An optimum layout is one with all components on the same side of the board, minimizing vias through other signal layers. Other signal traces should be routed away from the MK5818. This includes signal traces just underneath the device, or on layers adjacent to the ground plane layer used by the device.

### Crystal Information

The crystal used should be a fundamental mode (do not use third overtone), parallel resonant. Crystal capacitors should be connected from pins X1 to ground and X2 to ground to optimize the initial accuracy. The value of these capacitors is given by the following equation:

$$\text{Crystal caps (pF)} = (C_L - 6) \times 2$$

In the equation,  $C_L$  is the crystal load capacitance. So, for a crystal with a 16pF load capacitance, two 20 pF [(16-6) x 2] capacitors should be used.

### Spread Spectrum Profile

The MK5818 low EMI clock generator uses an optimized frequency slew rate algorithm to facilitate down stream tracking of zero delay buffers and other PLL devices. The

frequency modulation amplitude is constant with variations of the input frequency.

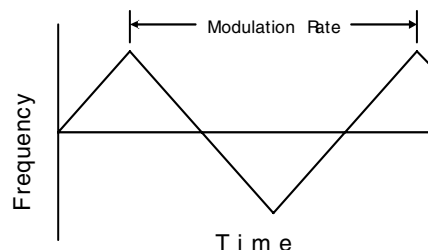

### Modulation Rate

The time required to transition from  $f_{\text{MIN}}$  (minimum frequency of the clock) to  $f_{\text{MAX}}$  (maximum frequency of the clock) and back to  $f_{\text{MIN}}$  is the period of the modulation rate,  $T_{\text{MOD}}$ . The modulation rates of spread spectrum clock generators are generally referred to in terms of frequency, and  $f_{\text{MOD}} = 1/T_{\text{MOD}}$ .

The input clock frequency ( $f_{\text{IN}}$ ) and the internal divider determine the modulation rate.

The spread spectrum modulation rate ( $f_{\text{MOD}}$ ) is given by the formula  $f_{\text{MOD}} = f_{\text{IN}}/\text{DR}$ , where:

$f_{\text{MOD}}$  is the modulation rate,  $f_{\text{IN}}$  is the input frequency, and DR is the divider ratio (see table below).

Input Frequency Range	Divider Ratio (DR)
8 to 16 MHz	256

## Absolute Maximum Ratings

Stresses above the ratings listed below can cause permanent damage to the MK5818. These ratings, which are standard values for IDT commercially rated parts, are stress ratings only. Functional operation of the device at these or any other conditions above those indicated in the operational sections of the specifications is not implied. Exposure to absolute maximum rating conditions for extended periods can affect product reliability. Electrical parameters are guaranteed only over the recommended operating temperature range.

Item	Rating
Supply Voltage, VDD	7 V
All Inputs and Outputs	-0.5 V to VDD+0.5 V
Ambient Operating Temperature	0 to +70° C
Storage Temperature	-65 to +150° C
Junction Temperature	125° C
Soldering Temperature	260° C

## Recommended Operation Conditions

Parameter	Min.	Typ.	Max.	Units
Ambient Operating Temperature	0		+70	°C
Power Supply Voltage (measured in respect to GND)	+2.97		3.63	V

## DC Electrical Characteristics

Unless stated otherwise, VDD = 3.3 V ±10%, Ambient Temperature 0 to +70° C

Parameter	Symbol	Conditions	Min.	Typ.	Max.	Units
Power Supply Range	V <sub>DD</sub>		2.97	3.3	3.63	V
Input High Voltage	V <sub>INH</sub>	S0 Input	0.85 V <sub>DD</sub>	V <sub>DD</sub>	V <sub>DD</sub>	V
Input Middle Voltage	V <sub>INM</sub>	S0 Input	0.40 V <sub>DD</sub>	0.50 V <sub>DD</sub>	0.60 V <sub>DD</sub>	V
Input Low Voltage	V <sub>INL</sub>	S0 Input	0.0	0.0	0.15 V <sub>DD</sub>	V
Output High Voltage	V <sub>OH1</sub>	I <sub>OH</sub> =4 ma, SSCLK and REFCLK	2.4			V
Output High Voltage	V <sub>OH2</sub>	I <sub>OH</sub> =6 ma, SSCLK and REFCLK	2.0			V
Output Low Voltage	V <sub>OL1</sub>	I <sub>OL</sub> =4 ma, SSCLK			0.4	V
Output Low Voltage	V <sub>OL2</sub>	I <sub>OL</sub> =10 ma, SSCLK			1.2	V
Power Supply Current	I <sub>DD2</sub>	F <sub>IN</sub> = 8MHz, no load		10.0	12.5	mA
Power Supply Current	I <sub>DD3</sub>	$\overline{\text{PD}}$ = GND		150	250	uA
Input Capacitance	C <sub>IN</sub>			5		pF
Internal pull-up resistor	R <sub>PU</sub>	SEL		360		kΩ

## AC Electrical Characteristics

Unless stated otherwise,  $V_{DD} = 3.3\text{ V} \pm 10\%$ , Ambient Temperature 0 to  $+70^{\circ}\text{C}$  and  $C_L = 15\text{pF}$

Parameter	Symbol	Conditions	Min.	Typ.	Max.	Units
Input Clock Frequency			8		16	MHz
Output Clock Frequency			8		16	MHz
Clock Rise Time	trise1	SSCLK and REFCLK, 0.4 V to 2.4 V,	2.0	3.0	4.0	ns
Clock Fall Time	tfall1	SSCLK and REFCLK, 0.4 V to 2.4 V	2.0	3.0	4.0	ns
Input Clock Duty Cycle		$X_1$	20	50	80	%
Output Clock Duty Cycle		SSCLK and REFCLK @ 1.5V	45	50	55	%
Cycle to cycle Jitter		SSCLK, $F_{in}=F_{out}=8\text{-}16\text{ MHz}$		250	350	ps
Cycle to cycle Jitter		REFCLK, $F_{in}=F_{out}=8\text{-}16\text{ MHz}$		275	375	ps
EMI Peak Frequency Reduction				8 to 16		dB

## Thermal Characteristics

Parameter	Symbol	Conditions	Min.	Typ.	Max.	Units
Thermal Resistance Junction to Ambient	$\theta_{JA}$	Still air		110		°C/W
	$\theta_{JA}$	1 m/s air flow		100		°C/W
	$\theta_{JA}$	3 m/s air flow		80		°C/W
Thermal Resistance Junction to Case	$\theta_{JC}$			35		°C/W

## Marking Diagram (Pb free)

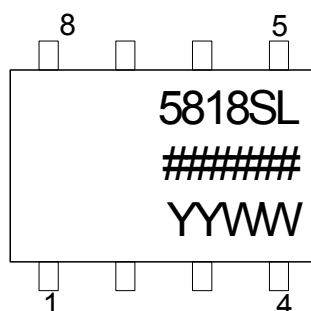

### Notes:

1. ##### is the lot code.
2. YYWW is the last two digits of the year, and the week number that the part was assembled.
3. "L" or "LF" denotes Pb (lead) free package.
4. Bottom marking: country of origin if not USA.

## Package Outline and Package Dimensions (8 pin SOIC, 150 Mil. Narrow Body)

Package dimensions are kept current with JEDEC Publication No. 95

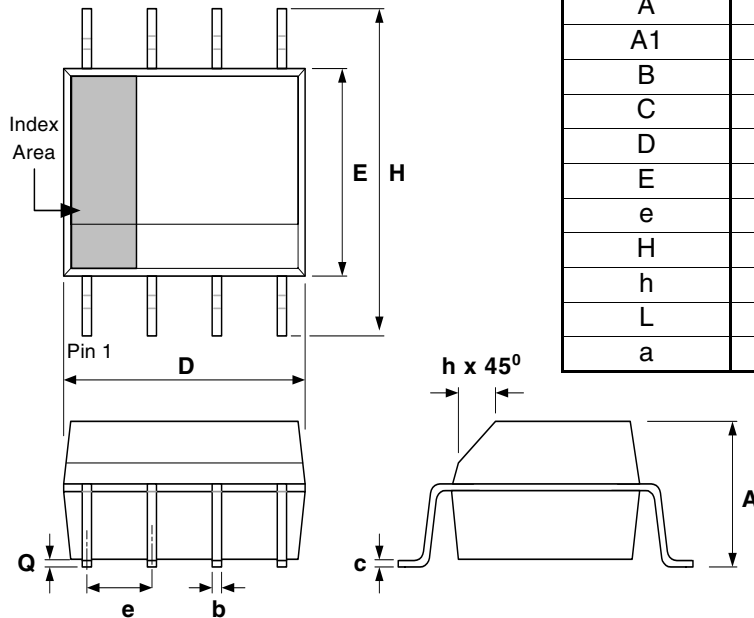

Symbol	Millimeters		Inches	
	Min	Max	Min	Max
A	1.35	1.75	0.0532	0.0688
A1	1.10	0.25	0.0040	0.0098
B	0.33	0.51	0.013	0.020
C	0.19	0.25	0.0075	0.0098
D	4.80	5.00	.1890	.1968
E	3.80	4.00	0.1497	0.1574
e	1.27 Basic		0.050 Basic	
H	5.80	6.20	0.2284	0.2440
h	0.25	0.50	0.010	0.020
L	0.40	1.27	0.016	0.050
a	0°	8°	0°	8°

## Ordering Information

Part / Order Number	Marking	Shipping Packaging	Package	Temperature
MK5818SLF	see page 6	Tubes	8-pin SOIC	0 to +70° C
MK5818SLFTR		Tape and Reel	8-pin SOIC	0 to +70° C

"LF" suffix to the part number are the Pb-Free configuration and are RoHS compliant.

While the information presented herein has been checked for both accuracy and reliability, Integrated Device Technology (IDT) assumes no responsibility for either its use or for the infringement of any patents or other rights of third parties, which would result from its use. No other circuits, patents, or licenses are implied. This product is intended for use in normal commercial applications. Any other applications such as those requiring extended temperature range, high reliability, or other extraordinary environmental requirements are not recommended without additional processing by IDT. IDT reserves the right to change any circuitry or specifications without notice. IDT does not authorize or warrant any IDT product for use in life support devices or critical medical instruments.





## IMPORTANT NOTICE AND DISCLAIMER

RENESAS ELECTRONICS CORPORATION AND ITS SUBSIDIARIES (“RENESAS”) PROVIDES TECHNICAL SPECIFICATIONS AND RELIABILITY DATA (INCLUDING DATASHEETS), DESIGN RESOURCES (INCLUDING REFERENCE DESIGNS), APPLICATION OR OTHER DESIGN ADVICE, WEB TOOLS, SAFETY INFORMATION, AND OTHER RESOURCES “AS IS” AND WITH ALL FAULTS, AND DISCLAIMS ALL WARRANTIES, EXPRESS OR IMPLIED, INCLUDING, WITHOUT LIMITATION, ANY IMPLIED WARRANTIES OF MERCHANTABILITY, FITNESS FOR A PARTICULAR PURPOSE, OR NON-INFRINGEMENT OF THIRD PARTY INTELLECTUAL PROPERTY RIGHTS.

These resources are intended for developers skilled in the art designing with Renesas products. You are solely responsible for (1) selecting the appropriate products for your application, (2) designing, validating, and testing your application, and (3) ensuring your application meets applicable standards, and any other safety, security, or other requirements. These resources are subject to change without notice. Renesas grants you permission to use these resources only for development of an application that uses Renesas products. Other reproduction or use of these resources is strictly prohibited. No license is granted to any other Renesas intellectual property or to any third party intellectual property. Renesas disclaims responsibility for, and you will fully indemnify Renesas and its representatives against, any claims, damages, costs, losses, or liabilities arising out of your use of these resources. Renesas' products are provided only subject to Renesas' Terms and Conditions of Sale or other applicable terms agreed to in writing. No use of any Renesas resources expands or otherwise alters any applicable warranties or warranty disclaimers for these products.

(Disclaimer Rev.1.0 Mar 2020)

### Corporate Headquarters

TOYOSU FORESIA, 3-2-24 Toyosu,  
Koto-ku, Tokyo 135-0061, Japan  
[www.renesas.com](http://www.renesas.com)

### Contact Information

For further information on a product, technology, the most up-to-date version of a document, or your nearest sales office, please visit:  
[www.renesas.com/contact/](http://www.renesas.com/contact/)

### Trademarks

Renesas and the Renesas logo are trademarks of Renesas Electronics Corporation. All trademarks and registered trademarks are the property of their respective owners.