

THIS DRAWING IS UNPUBLISHED. RELEASED FOR PUBLICATION
 © COPYRIGHT - By - ALL RIGHTS RESERVED.

| REVISIONS | | | | |
|-----------|-----|---------------------------|-----------|--------|
| P | LTR | DESCRIPTION | DATE | APVD |
| | H1 | REVISED PER ECO-11-004820 | 11MAR11 | RK HMR |
| | H2 | REVISED PER ECO-18-009926 | 26JUN2018 | RS DR |

| | | |
|--------------------------------|--------------------------------|--------------------------------|
| AMP WIRE RANGE | Listed | LR7189 Certified |
| 16-14 AWG SOLID OR STRANDED | 16-14 AWG SOLID OR STRANDED | 16-14 AWG SOLID OR STRANDED |

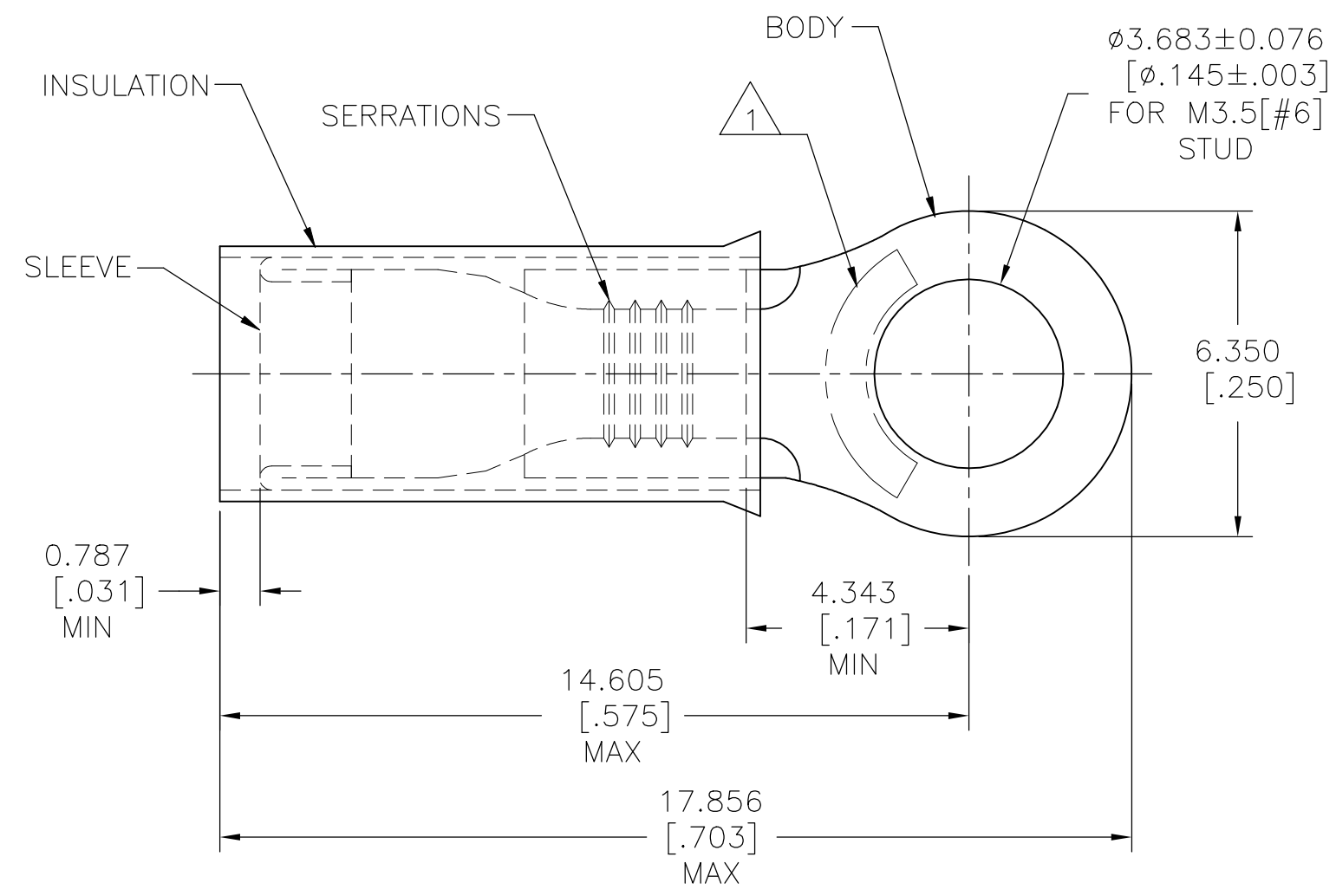

- 1 STAMP AMP 16-14*, APPROX AS SHOWN. STAMP MAY BE ON TOP OR BOTTOM
- 2 BODY THICKNESS IS 0.787±.051[.031±.002]
- 3 FOR 2.921 - 4.318[.115 - .170] WIRE INSULATION DIA
- 4 MAX RECOMMENDED OPERATING TEMP IS 105°C[221°F]
- 5 300 VOLT MAX RATING
- 6 WIRE CROSS SECTIONAL AREA RANGE 1.04-2.62mm [2,050-5,180 CIR MILS]

| | | | |
|------|------------------|---|------------|
| 100 | LOOSE PIECE, BOX | BODY & SLEEVE: COPPER PER ASTM B152 TIN PL. PER ASTM B-545 | 8-320619-1 |
| 5000 | ON TAPE, REEL | | 2-320619-1 |
| 1000 | LOOSE PIECE | INSULATION: NYLON COLOR: BLUE | 320619 |
| QTY | PACKAGING | MATERIAL / FINISH | PART NO |

| | | | | |
|--|----------|-------------------------------|----------------------|-----------------|
| THIS DRAWING IS A CONTROLLED DOCUMENT. | | DWN RAVI S 26JUN2018 | TE Connectivity Ltd. | |
| DIMENSIONS: mm [INCHES] | | CHK ROHDE DANIEL F 26JUN2018 | | |
| TOLERANCES UNLESS OTHERWISE SPECIFIED: | | APVD ROHDE DANIEL F 26JUN2018 | NAME | |
| 0 PLC ± - | | PRODUCT SPEC | WIRE TERMINAL | |
| 1 PLC ± - | | UL486A-B | PIDG, RING TONGUE | |
| 2 PLC ± - | | APPLICATION SPEC | WIRE SIZE: 16-14 AWG | |
| 3 PLC ± 0.127[.005] | | 114-2157 | SIZE A3 | CAGE CODE 00779 |
| 4 PLC ± - | | WEIGHT | DRAWING NO C-320619 | RESTRICTED TO - |
| ANGLES ± 1° | | CUSTOMER DRAWING | SCALE 8:1 | SHEET 1 OF 1 |
| MATERIAL - | FINISH - | | | REV H2 |