

40.0 x 10.0 x 3.2 (mm) LTE Full-Band Chip Antenna (CC40D7K) Engineering Specification

1. Product Number

H
2
U
E
6
P
1
K
2
R
0
1
0
0



2. Features

- * Compatible with LTE full-band/ 3G/ 2G/
- * Support LTE band 71 - 600MHz
- * Stable and reliable in performances
- * Compact size
- * RoHS2.0 compliance
- * SMT processes compatible

3. Applications

- * LTE full-band/ 3G/ 2G(included LTE B71).
- * LTE / GSM / CDMA /DCS /PCS / WCDMA / UMTS / HSDPA / GPRS / EDGE /IMT.

4. Description

Unictron's CC40D7K chip antenna is designed for cellular 2G/ 3G/ LTE bands applications, covering frequencies 617~698 MHz & 698~960 MHz & 1710~2690 MHz. Fabricated with proprietary design and processes, CC40D7K shows excellent performance and is fully compatible with SMT processes which can decrease the assembly cost and improve device's quality and consistency.



詠業科技股份有限公司
 Unictron Technologies Corporation
 Website:www.unictron.com

THIS DRAWINGS AND SPECIFICATIONS ARE THE PROPERTY OF UNICTRON TECHNOLOGIES CORPORATION AND SHALL NOT BE REPRODUCED OR USED AS THE BASIS FOR THE MANUFACTURE OR SALE OF APPARATUS OR DEVICES WITHOUT PERMISSION

Prepared by : **James** Designed by : **George Hung** Checked by : **Mike** Approved by : **Herbert**

| | | | |
|--|---------------------|-----------------------|---------------|
| TITLE : 40.0 x 10.0 x 3.2 (mm) LTE Full-Band PCB Chip Antenna (CC40D7K) Engineering Specification | DOCUMENT NO. | H2UE6P1K2R0100 | REV. A |
|--|---------------------|-----------------------|---------------|

5. Layout Guide & Electrical Specifications

5-1. Layout Guide (Unit: mm)

Solder Land Pattern:

The solder land pattern (gold marking areas) is shown below. Recommendation on matching circuit will be provided according to customer's installation conditions.

Top View

Bottom View

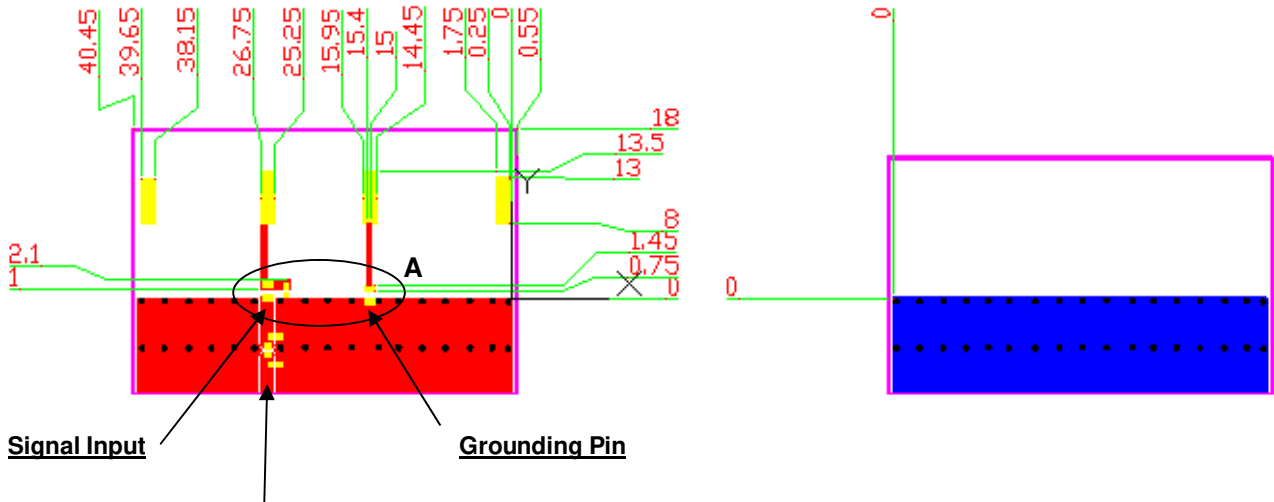

Transmission Line with 50Ω Impedance Characteristic

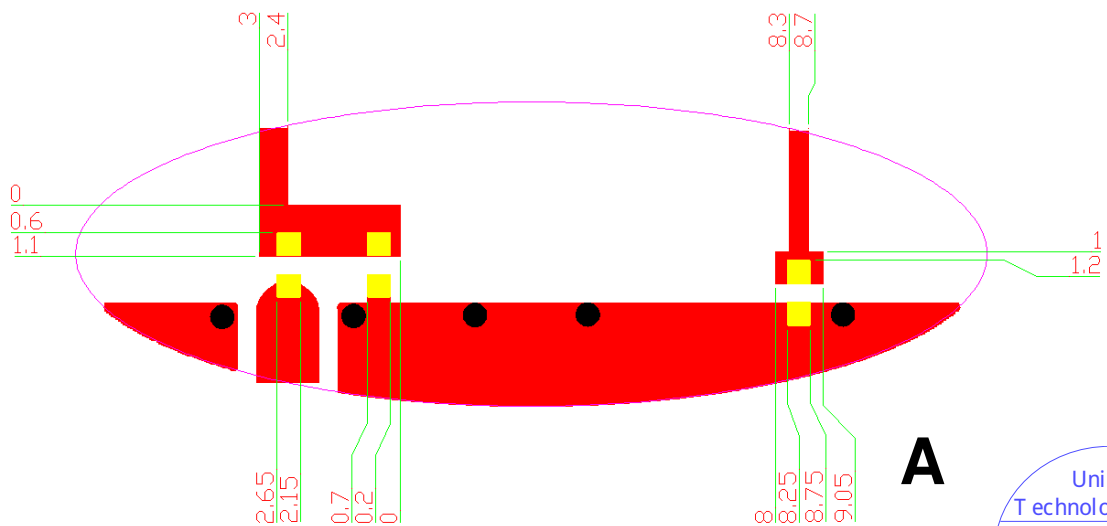

詠業科技股份有限公司
Unictron Technologies Corporation
Website: www.unictron.com

THIS DRAWINGS AND SPECIFICATIONS ARE THE PROPERTY OF UNICTRON TECHNOLOGIES CORPORATION AND SHALL NOT BE REPRODUCED OR USED AS THE BASIS FOR THE MANUFACTURE OR SALE OF APPARATUS OR DEVICES WITHOUT PERMISSION

Prepared by : James

Designed by : George Hung

Checked by : Mike

Approved by : Herbert

TITLE : 40.0 x 10.0 x 3.2 (mm) LTE Full-Band PCB Chip Antenna (CC40D7K) Engineering Specification

DOCUMENT NO.

H2UE6P1K2R0100

REV.
A

5-2. Electrical Specifications (with 138 x 41 mm² Evaluation Board)

5-2-1. Electrical Table

| Characteristics | Specifications | | | | |
|------------------------------|---------------------|-----------|-------------|-------------|-------------|
| Outline Dimension (mm) | 40.0 x 10.0 x 3.2 | | | | |
| Ground Plane Dimension (mm) | 138 x 41 | | | | |
| Working Frequency (MHz) | 617 ~ 798 | 824 ~ 960 | 1710 ~ 2170 | 2300 ~ 2400 | 2490 ~ 2690 |
| Peak Gain (dBi) (typical)** | 1.5 | 0.9 | 4.1 | 5.0 | 4.0 |
| Efficiency (%) (typical)** | 63.1 | 51 | 72.6 | 76.9 | 76.2 |
| VSWR (@ center frequency)* | < 5 : 1 | | | | |
| Characteristic Impedance (Ω) | 50 | | | | |
| Polarization | Linear Polarization | | | | |

*Center frequency means the frequency with the lowest value in return loss of the chip antenna on the evaluation board.

**A typical value is for reference only, not guaranteed.

5-2-2. Frequency vs. V.S.W.R

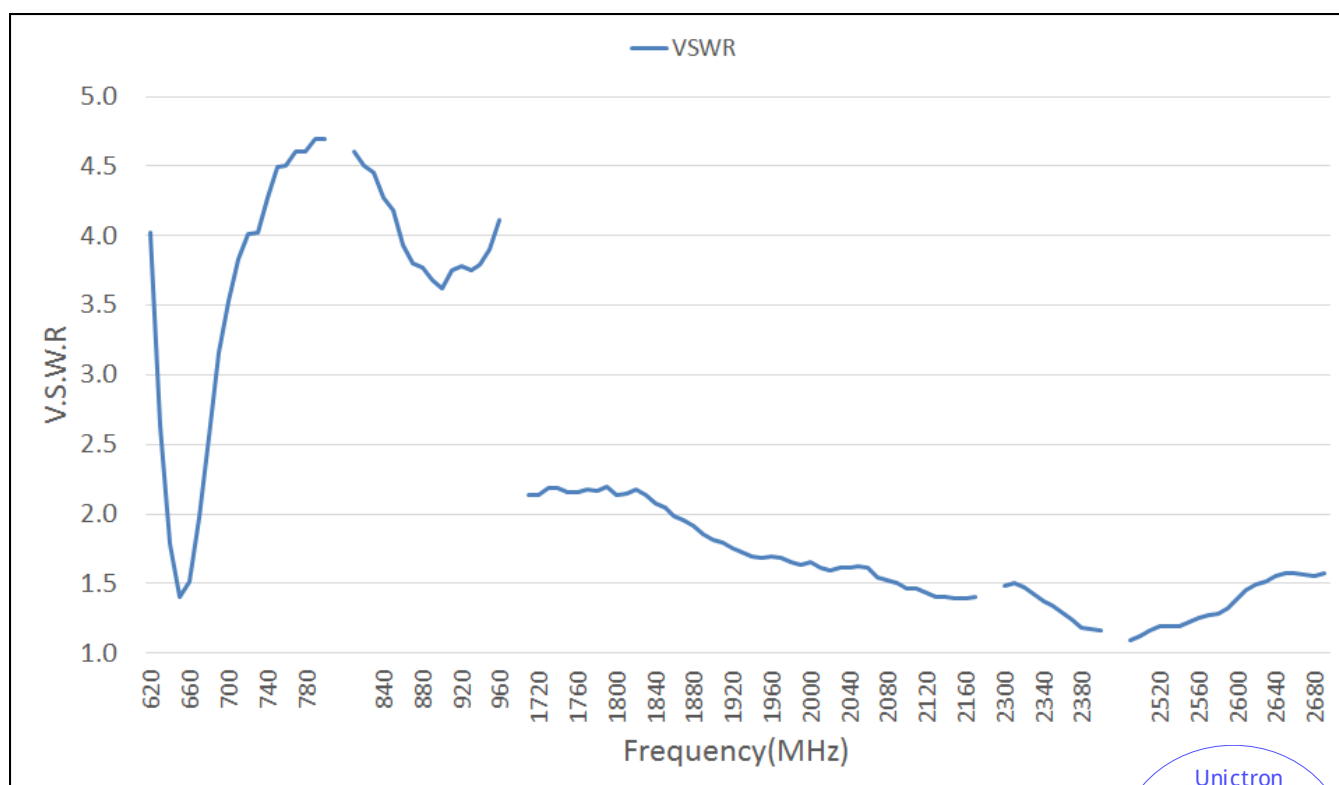

Unictron
Technologies Corp.
2020-04-20
Document
Control Center



詠業科技股份有限公司
Unictron Technologies Corporation
Website: www.unictron.com

THIS DRAWINGS AND SPECIFICATIONS ARE THE PROPERTY OF UNICTRON TECHNOLOGIES CORPORATION AND SHALL NOT BE REPRODUCED OR USED AS THE BASIS FOR THE MANUFACTURE OR SALE OF APPARATUS OR DEVICES WITHOUT PERMISSION

Prepared by : James

Designed by : George Hung

Checked by : Mike

Approved by : Herbert

TITLE : 40.0 x 10.0 x 3.2 (mm) LTE Full-Band PCB Chip Antenna (CC40D7K) Engineering Specification

DOCUMENT NO.

H2UE6P1K2R0100

REV.
A

5-2-3. Frequency vs. Efficiency(%)

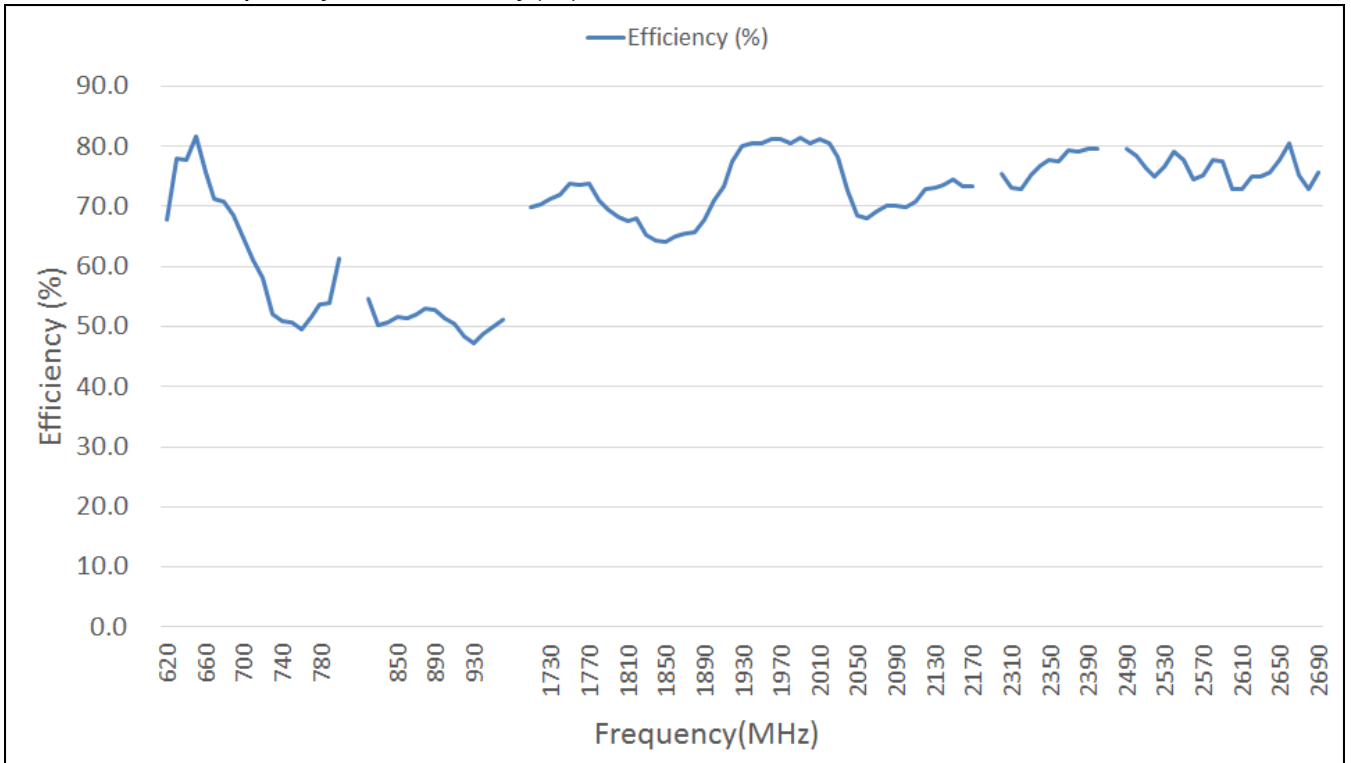

5-2-4. Frequency vs. Peak gain(dBi)

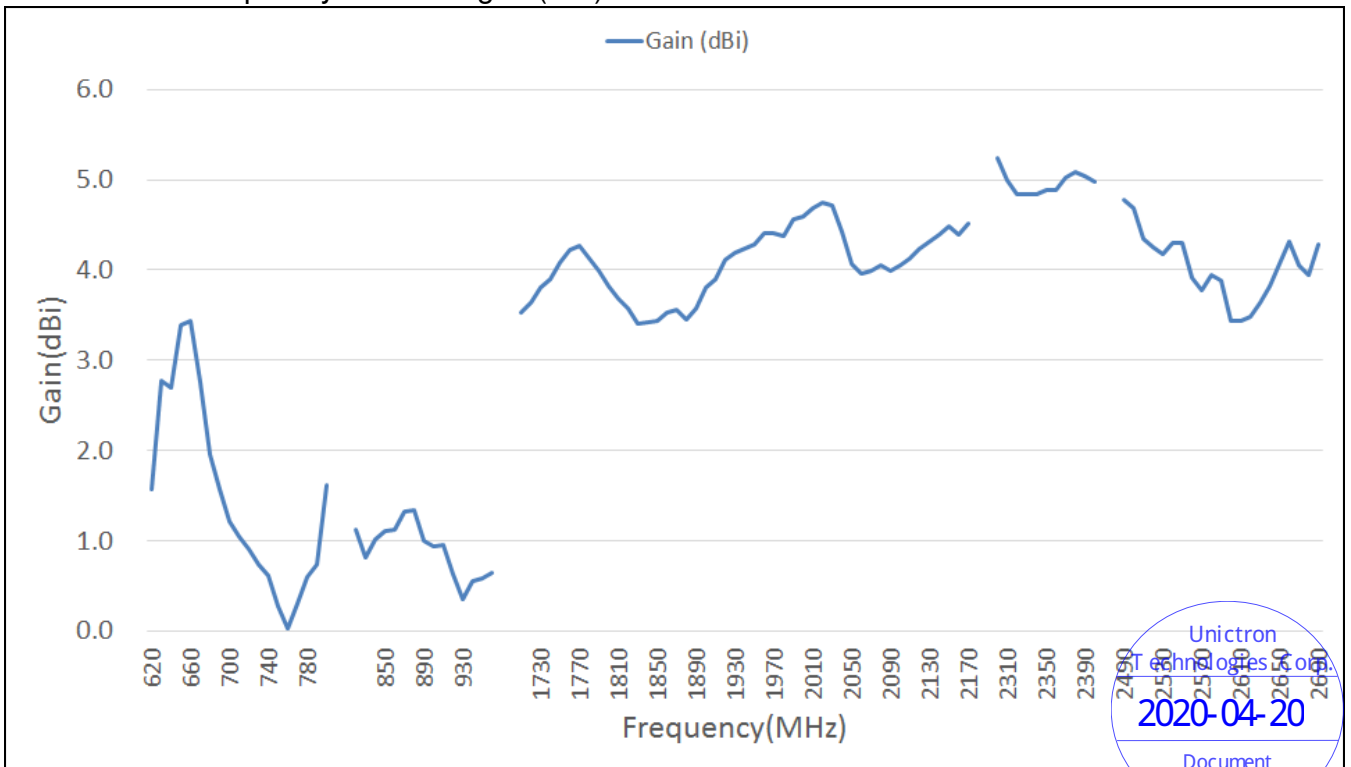

Unictron
Technologies Corp.
2020-04-20
Document
Control Center



詠業科技股份有限公司
Unictron Technologies Corporation
Website: www.unictron.com

THIS DRAWINGS AND SPECIFICATIONS ARE THE PROPERTY OF UNICTRON TECHNOLOGIES CORPORATION AND SHALL NOT BE REPRODUCED OR USED AS THE BASIS FOR THE MANUFACTURE OR SALE OF APPARATUS OR DEVICES WITHOUT PERMISSION

Prepared by : James Designed by : George Hung Checked by : Mike Approved by : Herbert

| | | | |
|---|--------------|----------------|------|
| TITLE : 40.0 x 10.0 x 3.2 (mm) LTE Full-Band PCB Chip Antenna (CC40D7K) Engineering Specification | DOCUMENT NO. | H2UE6P1K2R0100 | REV. |
| | | | A |

5-2-5. Frequency vs. V.S.W.R. and Total Radiation Gain

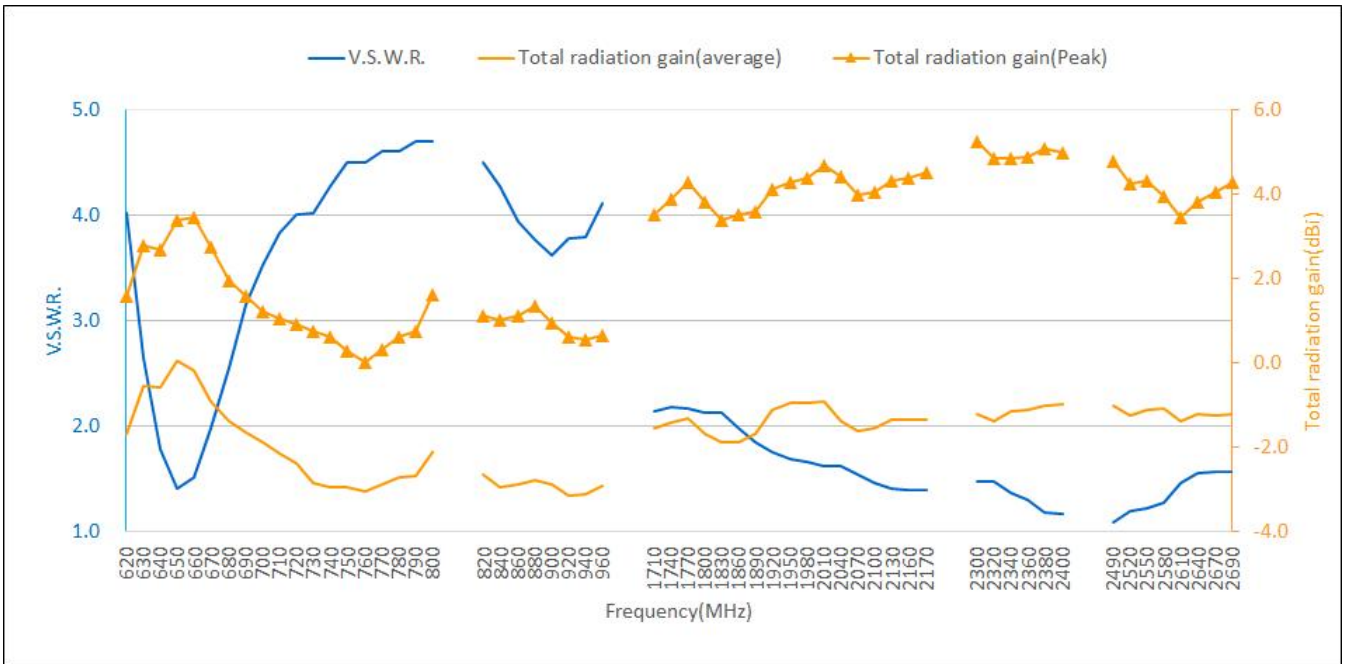

詠業科技股份有限公司
Unictron Technologies Corporation
Website: www.unictron.com

THIS DRAWINGS AND SPECIFICATIONS ARE THE PROPERTY OF UNICTRON TECHNOLOGIES CORPORATION AND SHALL NOT BE REPRODUCED OR USED AS THE BASIS FOR THE MANUFACTURE OR SALE OF APPARATUS OR DEVICES WITHOUT PERMISSION

Prepared by : James Designed by : George Hung Checked by : Mike Approved by : Herbert

| | | | |
|---|--------------|----------------|------|
| TITLE : 40.0 x 10.0 x 3.2 (mm) LTE Full-Band PCB Chip Antenna (CC40D7K) Engineering Specification | DOCUMENT NO. | H2UE6P1K2R0100 | REV. |
| | | | A |

6. Outline Dimensions of Antenna & Evaluation Board (Unit: mm)

6-1. Antenna Dimensions

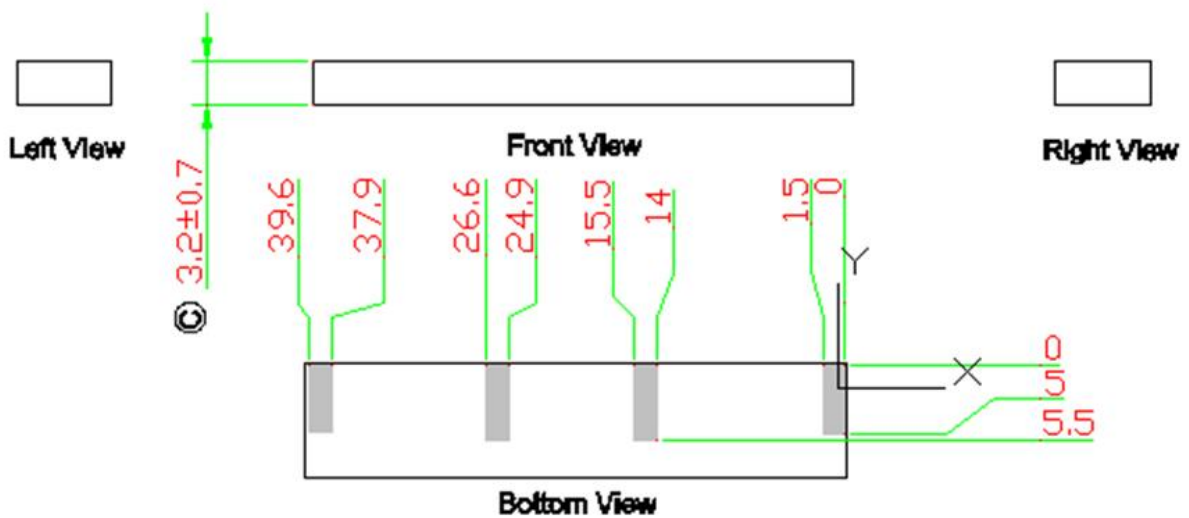
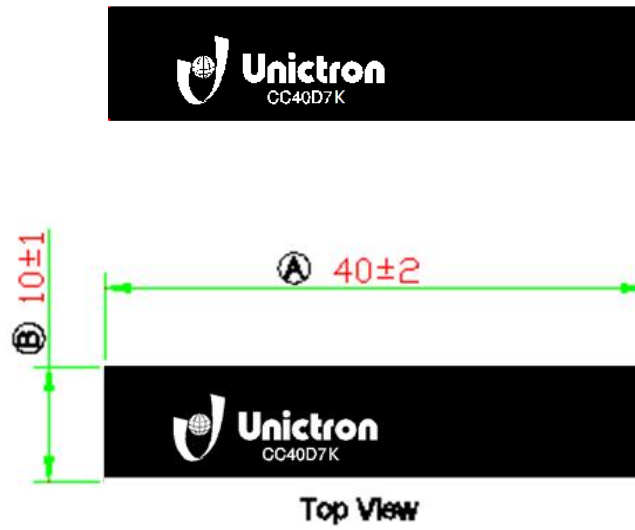

NOTE:

1. All materials are RoHS 2.0 compliant.
2. "A~C" Critical Dimensions.
3. "()" Reference Dimensions.



詠業科技股份有限公司
Unictron Technologies Corporation
Website: www.unictron.com

THIS DRAWINGS AND SPECIFICATIONS ARE THE PROPERTY OF UNICTRON TECHNOLOGIES CORPORATION AND SHALL NOT BE REPRODUCED OR USED AS THE BASIS FOR THE MANUFACTURE OR SALE OF APPARATUS OR DEVICES WITHOUT PERMISSION

Prepared by : James

Designed by : George Hung

Checked by : Mike

Approved by : Herbert

TITLE : 40.0 x 10.0 x 3.2 (mm) LTE Full-Band PCB Chip Antenna (CC40D7K) Engineering Specification

DOCUMENT NO.

H2UE6P1K2R0100

REV.

A

PIN Definition

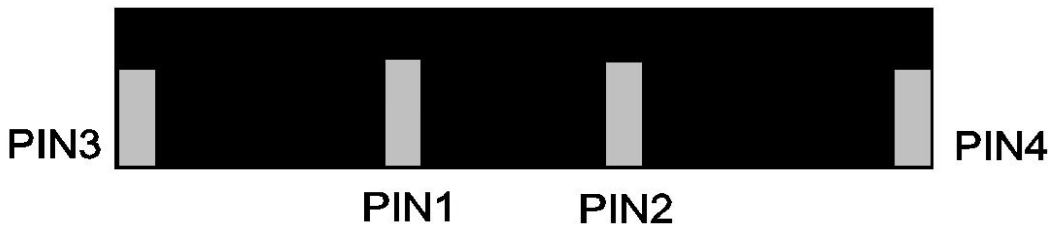

Bottom View

| PIN | 1 | 2 | 3~4 |
|---------------|---------------|--------|-----|
| Soldering Pad | Tuning/Ground | Signal | N/C |

6-2. Evaluation Board & Antenna Location

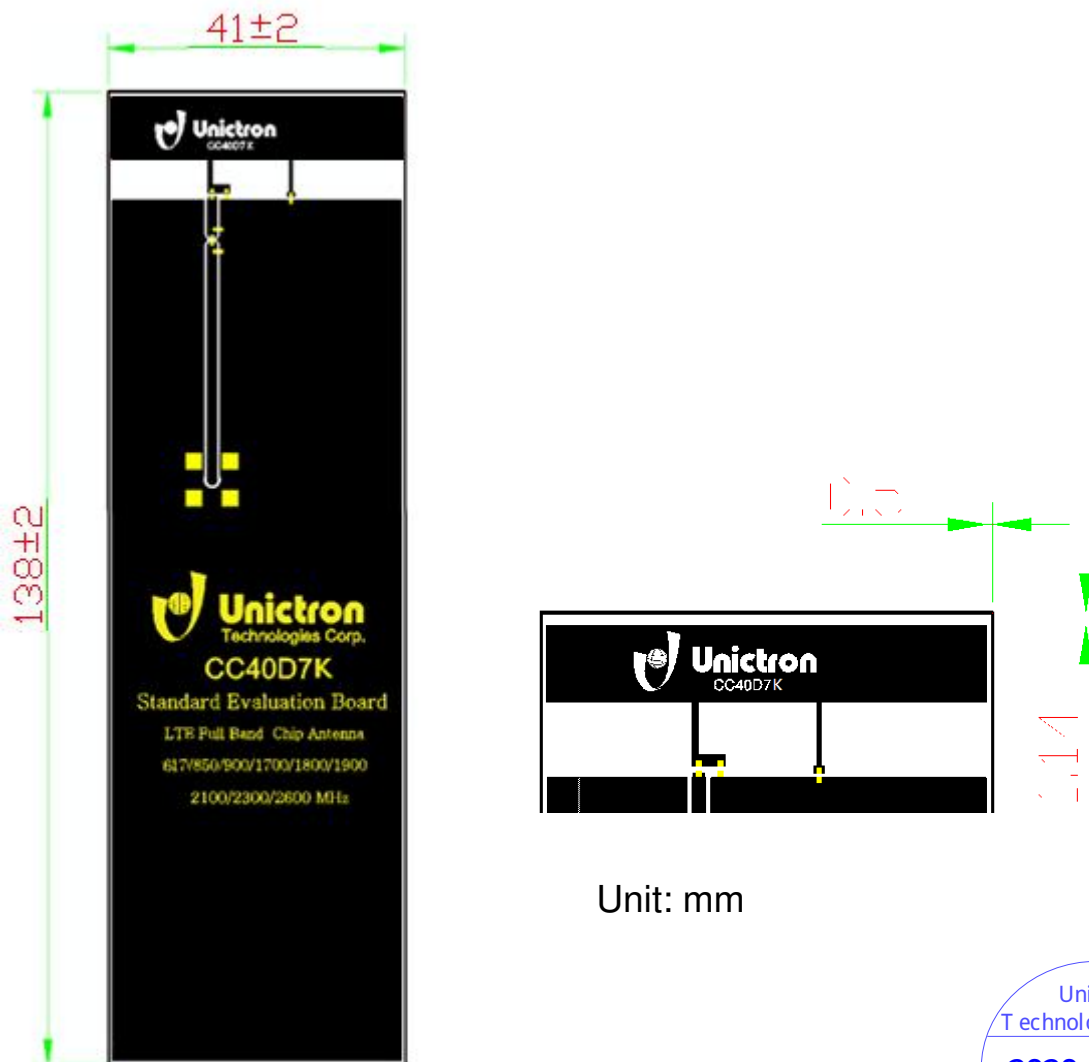

Unit: mm



詠業科技股份有限公司
Unicon Technologies Corporation
Website: www.unicon.com

THIS DRAWINGS AND SPECIFICATIONS ARE THE PROPERTY OF UNICTRON TECHNOLOGIES CORPORATION AND SHALL NOT BE REPRODUCED OR USED AS THE BASIS FOR THE MANUFACTURE OR SALE OF APPARATUS OR DEVICES WITHOUT PERMISSION

Prepared by : James

Designed by : George Hung

Checked by : Mike

Approved by : Herbert

TITLE : 40.0 x 10.0 x 3.2 (mm) LTE Full-Band PCB Chip Antenna (CC40D7K) Engineering Specification

DOCUMENT NO.

H2UE6P1K2R0100

REV.
A

7. 3D Radiation Gain Pattern (with 138 x 41 mm² Evaluation Board)

7-1. 617~698MHz Band

3D Radiation Gain Pattern @ 660 MHz (Unit: dBi)

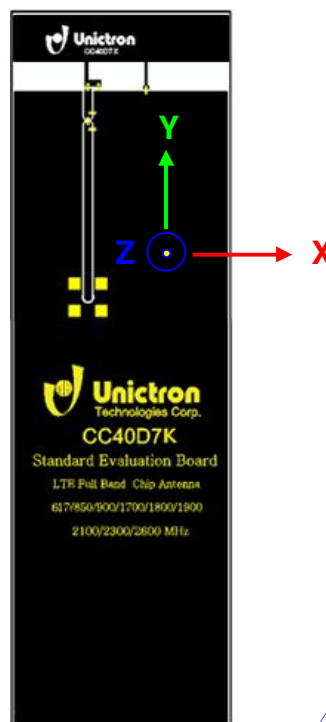
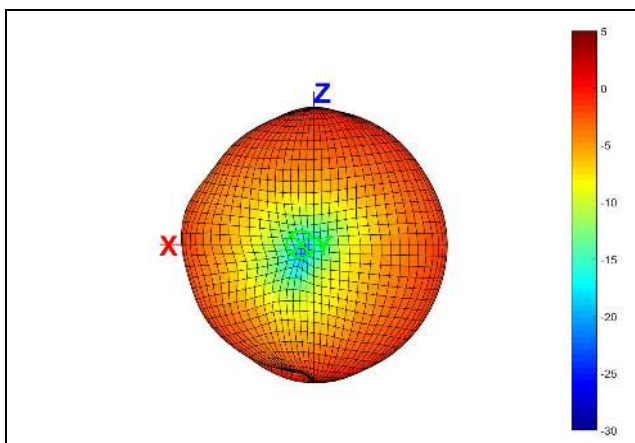
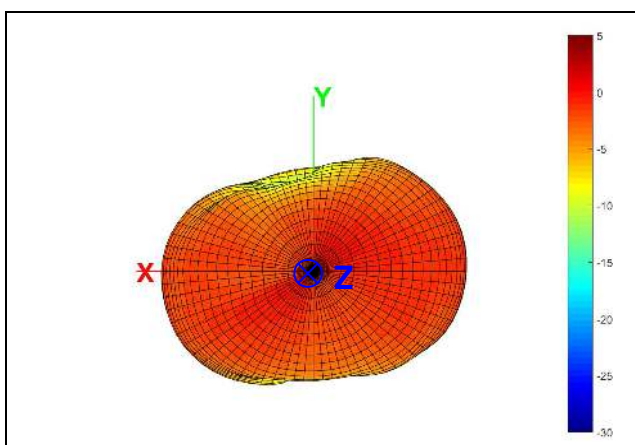
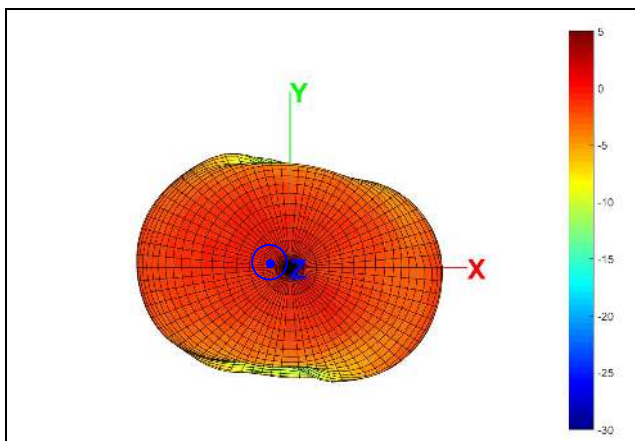

詠業科技股份有限公司
Unictron Technologies Corporation
Website: www.unictron.com

THIS DRAWINGS AND SPECIFICATIONS ARE THE PROPERTY OF UNICTRON TECHNOLOGIES CORPORATION AND SHALL NOT BE REPRODUCED OR USED AS THE BASIS FOR THE MANUFACTURE OR SALE OF APPARATUS OR DEVICES WITHOUT PERMISSION

Prepared by : James

Designed by : George Hung

Checked by : Mike

Approved by : Herbert

TITLE : 40.0 x 10.0 x 3.2 (mm) LTE Full-Band PCB Chip Antenna (CC40D7K) Engineering Specification

DOCUMENT NO.

H2UE6P1K2R0100

REV. A

7-2. 698~798MHz Band

3D Radiation Gain Pattern @ 748 MHz (Unit: dBi)

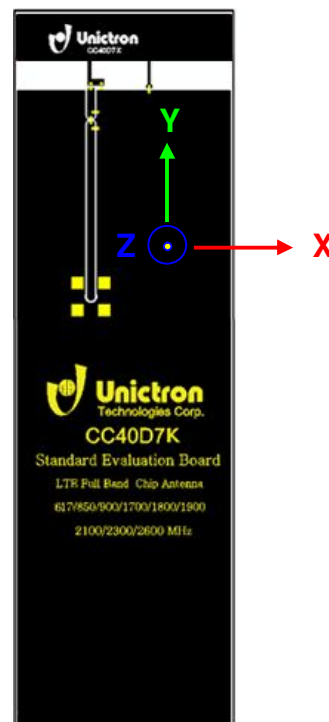
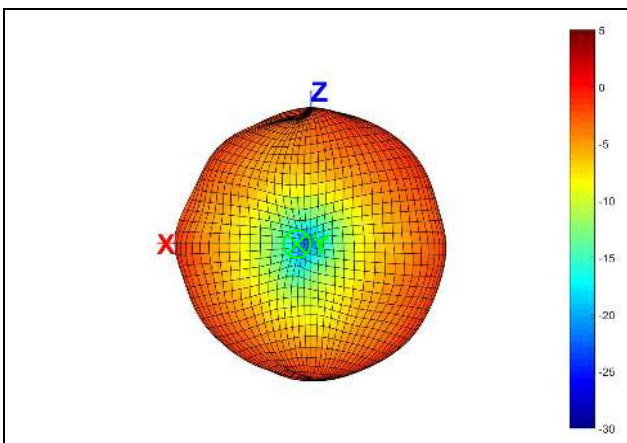
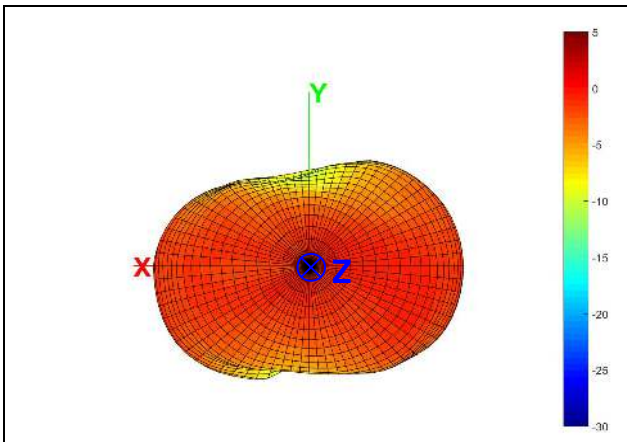
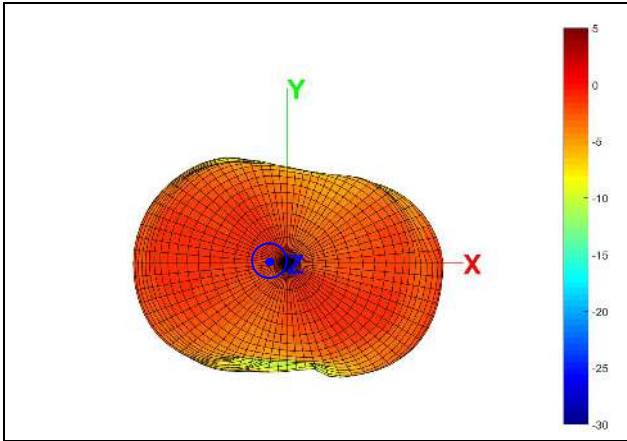

詠業科技股份有限公司
Uniconn Technologies Corporation
Website: www.uniconn.com

THIS DRAWINGS AND SPECIFICATIONS ARE THE PROPERTY OF UNICONN TECHNOLOGIES CORPORATION AND SHALL NOT BE REPRODUCED OR USED AS THE BASIS FOR THE MANUFACTURE OR SALE OF APPARATUS OR DEVICES WITHOUT PERMISSION

Prepared by : James

Designed by : George Hung

Checked by : Mike

Approved by : Herbert

TITLE : 40.0 x 10.0 x 3.2 (mm) LTE Full-Band PCB Chip Antenna (CC40D7K) Engineering Specification

DOCUMENT NO.

H2UE6P1K2R0100

REV.
A

7-3. 824~960MHz Band

3D Radiation Gain Pattern @ 890 MHz (Unit: dBi)

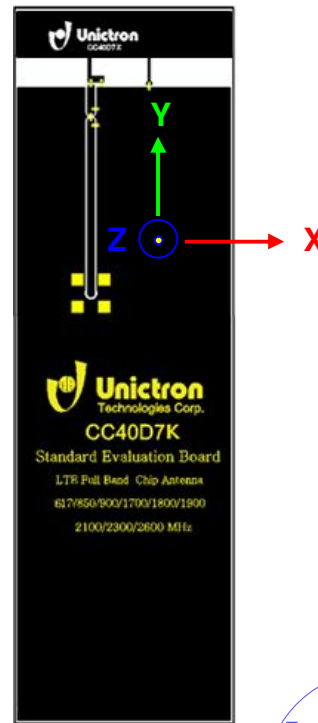
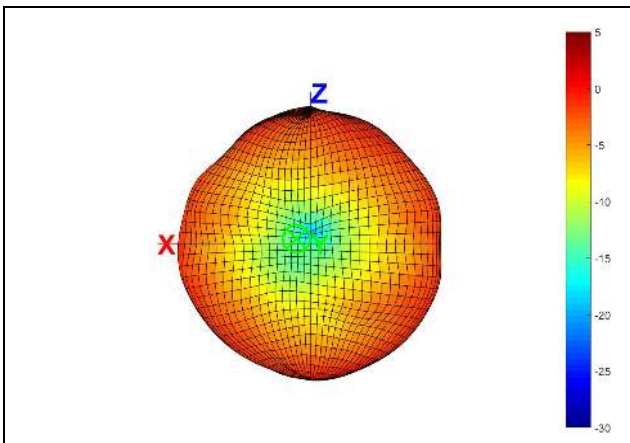
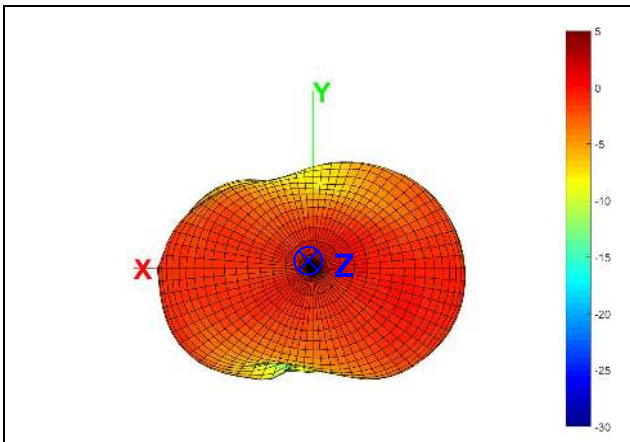
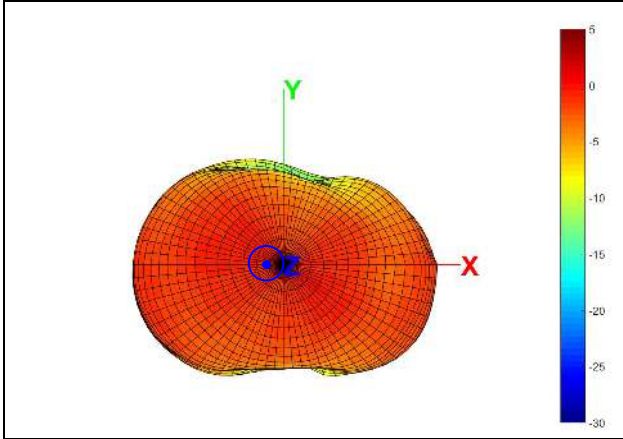

Uniconn
Technologies Corp.
2020-04-20
Document
Control Center



詠業科技股份有限公司
Uniconn Technologies Corporation
Website: www.uniconn.com

THIS DRAWINGS AND SPECIFICATIONS ARE THE PROPERTY OF UNICONN TECHNOLOGIES CORPORATION AND SHALL NOT BE REPRODUCED OR USED AS THE BASIS FOR THE MANUFACTURE OR SALE OF APPARATUS OR DEVICES WITHOUT PERMISSION

Prepared by : James

Designed by : George Hung

Checked by : Mike

Approved by : Herbert

TITLE : 40.0 x 10.0 x 3.2 (mm) LTE Full-Band PCB Chip Antenna (CC40D7K) Engineering Specification

DOCUMENT NO.

H2UE6P1K2R0100

REV.
A

7-4. 1710~2170MHz Band

3D Radiation Gain Pattern @ 1950 MHz (Unit: dBi)

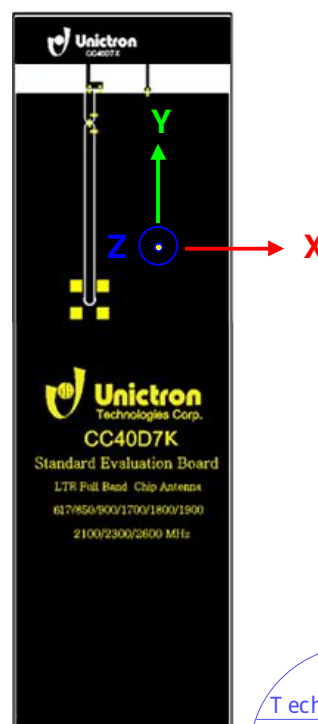
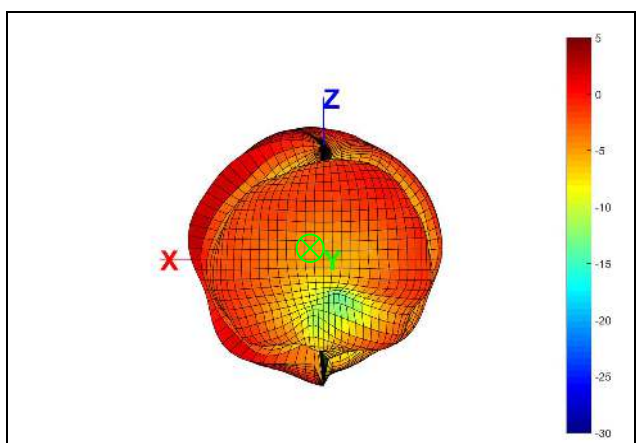
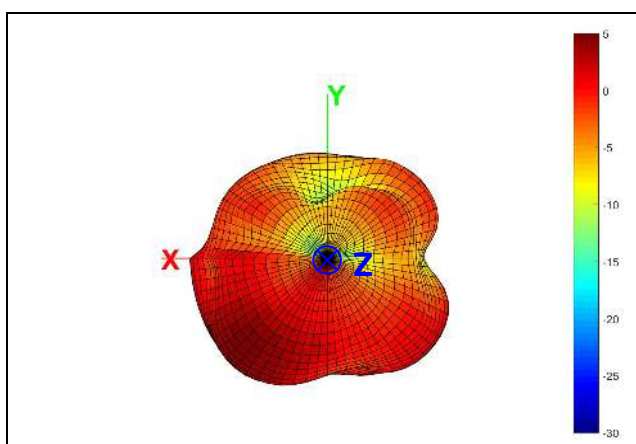
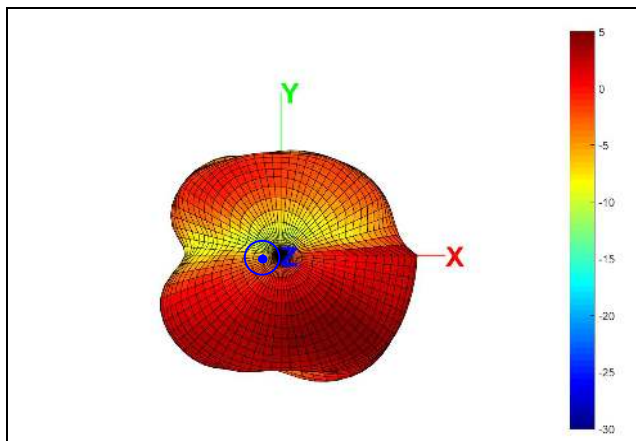

Uniconn
Technologies Corp.
2020-04-20
Document
Control Center



詠業科技股份有限公司
Uniconn Technologies Corporation
Website: www.uniconn.com

THIS DRAWINGS AND SPECIFICATIONS ARE THE PROPERTY OF UNICONN TECHNOLOGIES CORPORATION AND SHALL NOT BE REPRODUCED OR USED AS THE BASIS FOR THE MANUFACTURE OR SALE OF APPARATUS OR DEVICES WITHOUT PERMISSION

Prepared by : James

Designed by : George Hung

Checked by : Mike

Approved by : Herbert

TITLE : 40.0 x 10.0 x 3.2 (mm) LTE Full-Band PCB Chip Antenna (CC40D7K) Engineering Specification

DOCUMENT NO.

H2UE6P1K2R0100

REV.
A

7-5. 2300~2400MHz Band

3D Radiation Gain Pattern @ 2350 MHz (Unit: dBi)

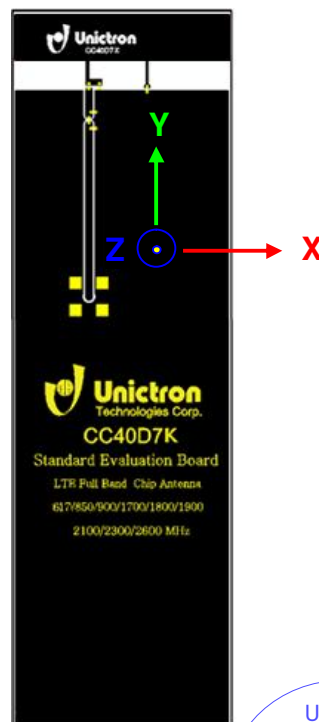
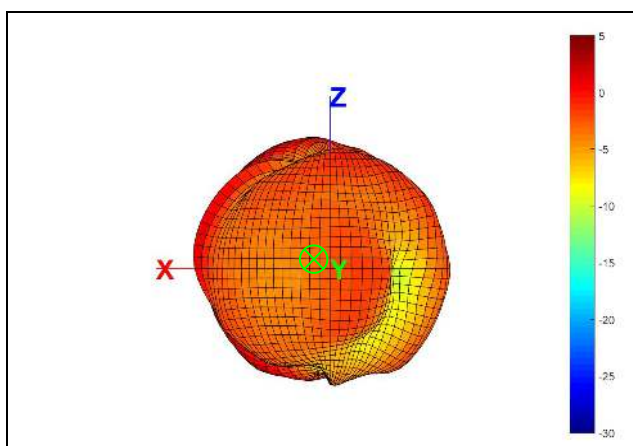
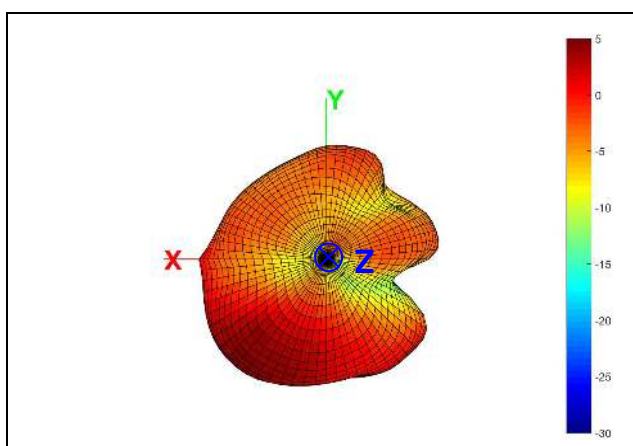
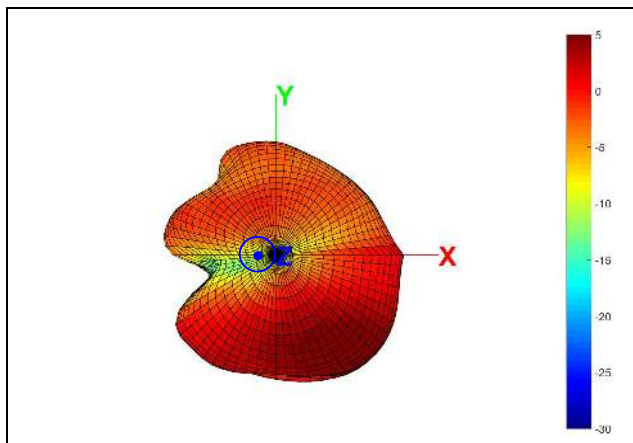

Unictron
Technologies Corp.
2020-04-20
Document
Control Center



詠業科技股份有限公司
Unictron Technologies Corporation
Website: www.unictron.com

THIS DRAWINGS AND SPECIFICATIONS ARE THE PROPERTY OF UNICTRON TECHNOLOGIES CORPORATION AND SHALL NOT BE REPRODUCED OR USED AS THE BASIS FOR THE MANUFACTURE OR SALE OF APPARATUS OR DEVICES WITHOUT PERMISSION

Prepared by : James

Designed by : George Hung

Checked by : Mike

Approved by : Herbert

TITLE : 40.0 x 10.0 x 3.2 (mm) LTE Full-Band PCB Chip Antenna (CC40D7K) Engineering Specification

DOCUMENT NO.

H2UE6P1K2R0100

REV. A

7-6. 2490~2690MHz Band

3D Radiation Gain Pattern @ 2590 MHz (Unit: dBi)

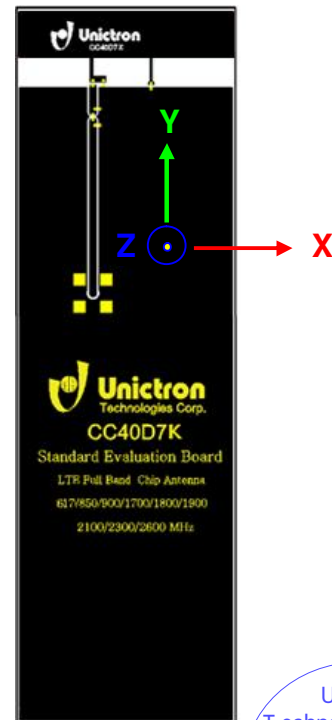
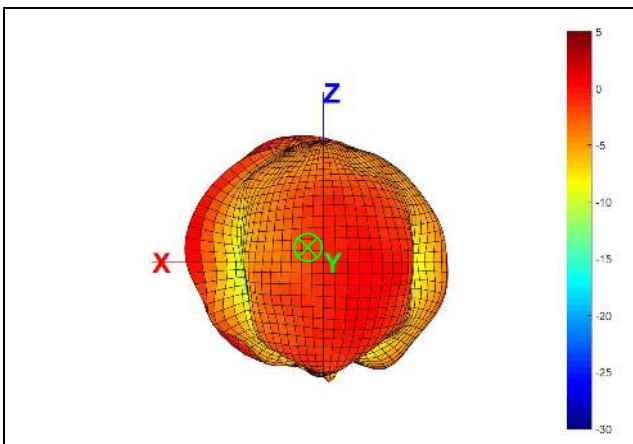
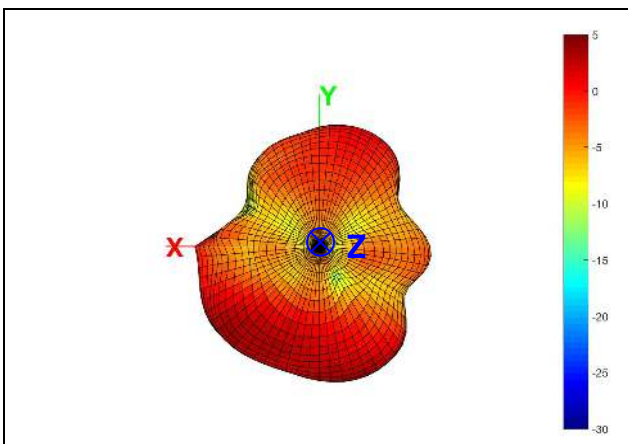
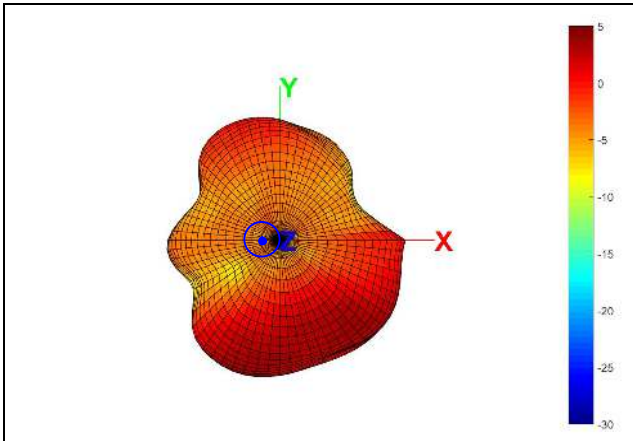

Unicon Technologies Corp.
2020-04-20
Document Control Center



詠業科技股份有限公司
Unicon Technologies Corporation
Website: www.unicon.com

THIS DRAWINGS AND SPECIFICATIONS ARE THE PROPERTY OF UNICON TECHNOLOGIES CORPORATION AND SHALL NOT BE REPRODUCED OR USED AS THE BASIS FOR THE MANUFACTURE OR SALE OF APPARATUS OR DEVICES WITHOUT PERMISSION

Prepared by : James

Designed by : George Hung

Checked by : Mike

Approved by : Herbert

TITLE : 40.0 x 10.0 x 3.2 (mm) LTE Full-Band PCB Chip Antenna (CC40D7K) Engineering Specification

DOCUMENT NO.

H2UE6P1K2R0100

REV. A

8. Frequency tuning and Matching circuit

8-1. Chip antenna tuning scenario :

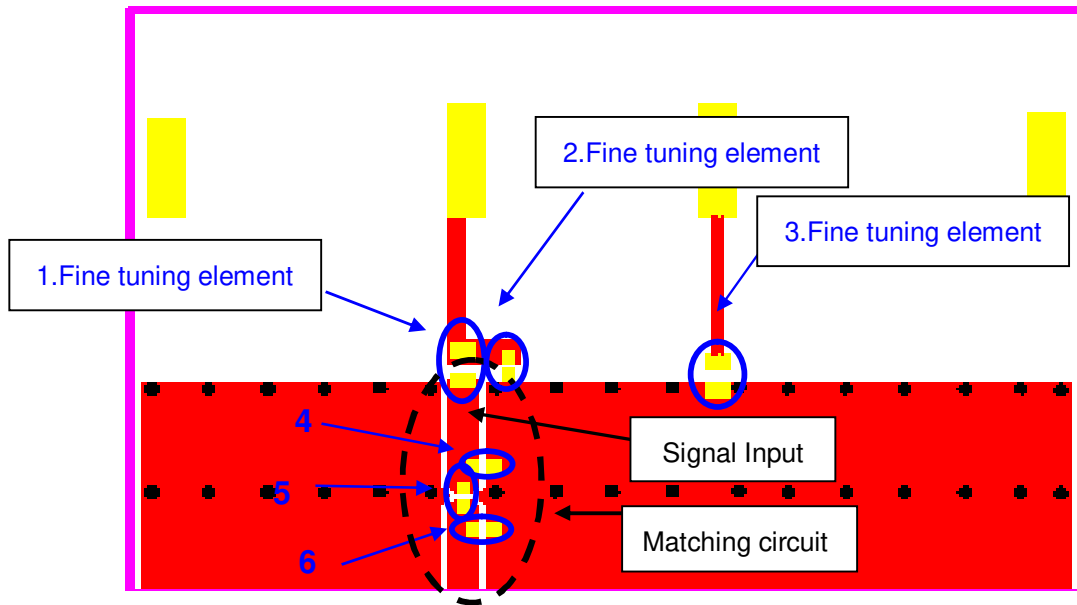

8-2. Matching circuit :

With the following recommended values of matching and tuning components, the covering frequencies will be about 617~960 MHz & 1710~2690 MHz at our standard 138 x 41 mm² evaluation board. However, these are typical reference values which may need to be changed when circuit boards or part vendors are different.

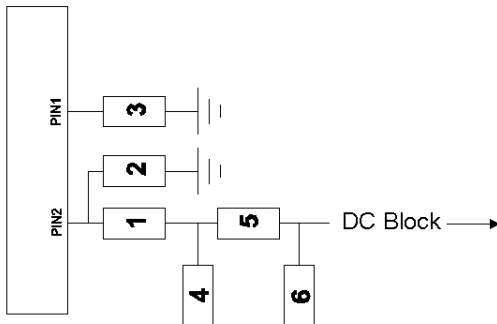

| System Matching Circuit Component | | | |
|-----------------------------------|----------------|--------|-----------|
| Location | Description | Vendor | Tolerance |
| 1 Fine tuning element | 3.3pF, (0402) | MURATA | ±0.05pF |
| 2 Fine tuning element | N/C | - | - |
| 3 Fine tuning element | 9.3 nH, (0402) | MURATA | ±2% |
| 4 | N/C | - | - |
| 5 | 4.7 nH, (0402) | MURATA | ±0.3 nH |
| 6 | N/C | | |

Unictron
Technologies Corp.

2020-04-20

Document
Control Center



詠業科技股份有限公司
Unictron Technologies Corporation
Website: www.unictron.com

THIS DRAWINGS AND SPECIFICATIONS ARE THE PROPERTY OF UNICTRON TECHNOLOGIES CORPORATION AND SHALL NOT BE REPRODUCED OR USED AS THE BASIS FOR THE MANUFACTURE OR SALE OF APPARATUS OR DEVICES WITHOUT PERMISSION

Prepared by : James

Designed by : George Hung

Checked by : Mike

Approved by : Herbert

TITLE : 40.0 x 10.0 x 3.2 (mm) LTE Full-Band PCB Chip Antenna (CC40D7K) Engineering Specification

DOCUMENT NO.

H2UE6P1K2R0100

REV.
A