

# **AT89STK-11 Starter Kit**

---

## **Hardware User Guide**



---

**Section 1**

Introduction .....	1-1
1.1 Features .....	1-1
1.2 Supported Devices .....	1-2

---

**Section 2**

Hardware Description .....	2-4
2.1 Board Overview .....	2-4
2.2 Block Diagram .....	2-5
2.3 Power Supply .....	2-5
2.4 Reset .....	2-6
2.5 Features .....	2-7
2.6 Interfaces .....	2-7
2.7 Board Settings .....	2-9

---

**Section 3**

ISP Programming .....	3-12
3.1 Manual ISP Mode .....	3-12
3.2 Auto ISP Mode .....	3-12
3.3 FLIP Software .....	3-13
3.4 Batchisp Software .....	3-13

---

**Section 4**

Appendix A: Board Layout .....	4-14
Appendix B: Bill of Materials .....	4-15
4.1 Bill of Materials Table .....	4-15
Appendix C: Board Schematics .....	4-17
Appendix D: References/Acronyms .....	4-22
4.2 References .....	4-22
4.3 Acronyms .....	4-22



# Section 1

---

## Introduction

This document describes the AT89STK-11 board dedicated to the standard C51 micro-controllers with in-system programming.

All of the microcontroller I/Os are made available in an expansion area with prototyping facilities.

---

### 1.1 Features

- Stand-alone Board
- In-System Programmable (ISP) including 'Auto ISP' feature
- On-board Voltage Regulator
- Microcontroller on its sockets
  - PLCC44-pin package
- On-board 3V or 5V power supply circuitry
  - from an external power connector
  - from an external battery
- On-board RESET
- Leds : Power, ALE, RS232 Rx and Tx
- External MCU clock connector
- External PCA clock connector
- TWI, SPI and RS232 connectors
- INT0 & INT1 Push-button
- Expansion area with prototyping facilities
- Commercial Temperature Range: 0 to +70°C Operating Temperature
- Dimension: 95 mm x 120 mm

---

**1.2 Supported Devices**

- AT89C51RE2
- AT89C51RB2
- AT89C51RC2/IC2
- AT89C51RD2/ID2/ED2



## Section 2

# Hardware Description

2.1 **Board Overview** Figure 2-1 shows the AT89STK-11 board.

*Figure 2-1.* AT89STK-11

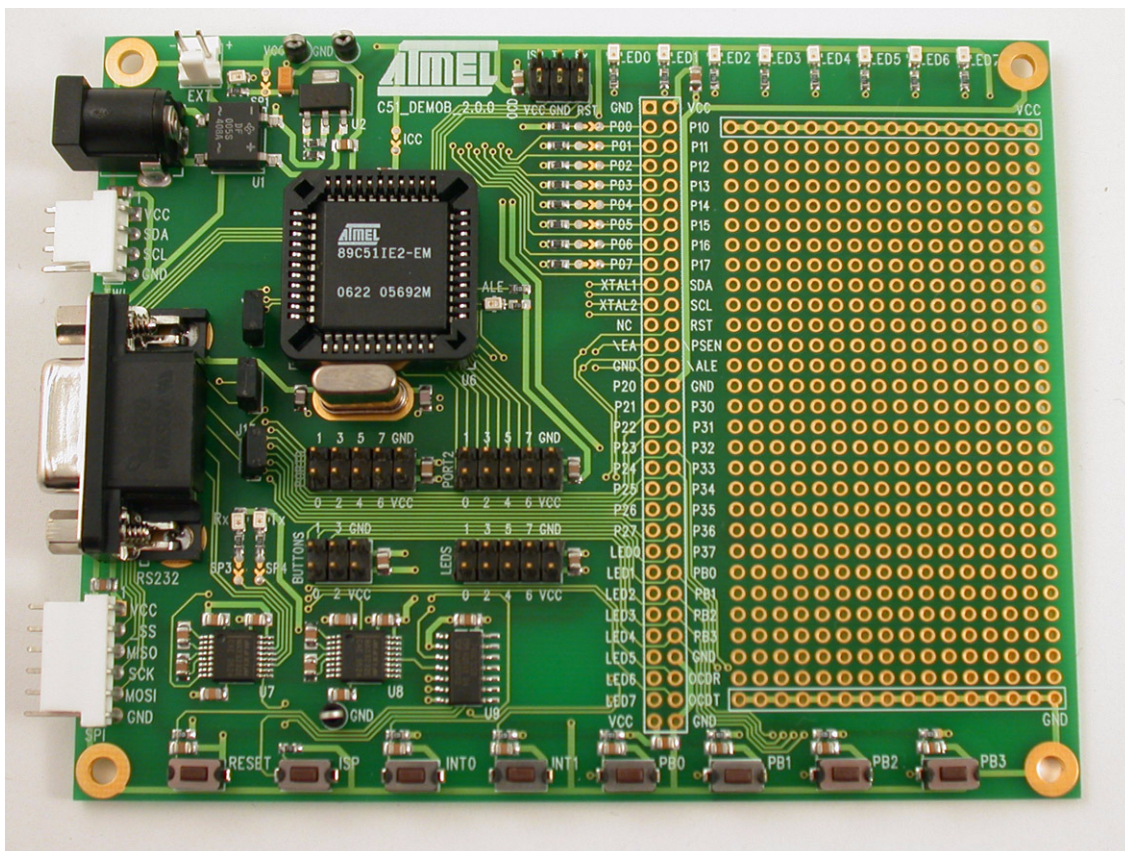

This photo is not contractual and may be modified without notification by Atmel.

**2.2 Block Diagram** Figure 2-2 shows the functional block diagram of the AT89STK-11, with the I/O usage.

Figure 2-2. Block Diagram of AT89STK-11

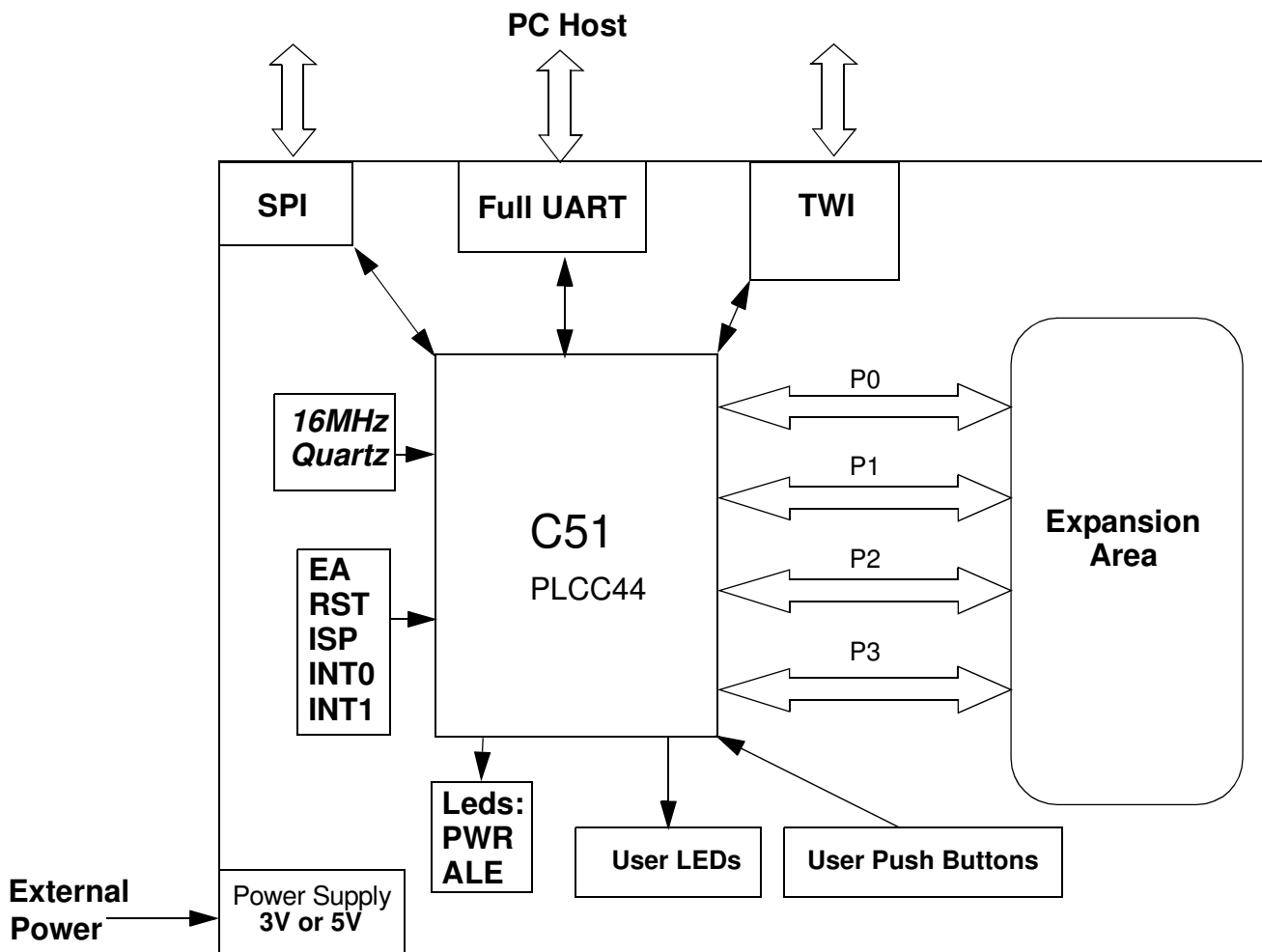

**2.3 Power Supply** The on-board power supply circuitry allows various power supply configurations. This gives the user the capability to power the devices in the 3V and in the 5V voltage range.

- 2.3.1 Power Supply Sources** The power supply source can come from two different and **exclusive** sources:
- either from the JACK PWR connector
  - either from the 2-point sip EXT connector.

**2.3.1.1 JACK PWR Connector** The Jack power connector implemented on board is a female Jack connector with internal 2.1mm conductor. It requires a male JACK outlet with 2.1mm capability.

No specific polarization is mandatory as on-board diode rectifier gives a protection against inadvertent polarization inversion.

When using the JACK power supply, the board is powered with a 5V voltage.

**Figure 2-3.** Male JACK Outlet and Wires

**Note:** Do not mount more than **one** power supply source on AT89STK-11 Board.

**Note:** There is a diode voltage level between the negative output of the power supply and the “GND”. This could introduce some voltage gap during measurement and instrumentation.

### 2.3.1.2 External EXT connector

The battery power connector implemented on board is a male two point SIP connector. It requires an external power cable with a female 2 points connector.

When powered through this interface, polarization is mandatory as no protection is given on board.

The EXT power supply circuitry support input supply from 2.7V up to 5.5V DC.

**Figure 2-4.** EXT PWR Female Connector / Cable

**Note:** Do not mount more than **one** power supply source on board.

**Note:** Keep SP1 closed when using the EXT input

<b>2.4</b>	<b>Reset</b>	To be compatible with Atmel microcontrollers which have (or not) its on-chip RESET circuitry (c.f. microcontroller datasheet), the board provides a RESET signal witch can come from 2 different sources:
<b>2.4.1</b>	<b>Power-on RESET</b>	The on-board RC network acts as power-on RESET.
<b>2.4.2</b>	<b>RESET Push Button</b>	By pressing the RESET push button on the board, a warm RESET of the microcontroller is performed.

- 
- 2.5 Features** This section presents the various features such as leds, buttons, etc... available on the board.
- 2.5.1 Push-Buttons**
- RESET can be used to apply warm reset to the MCU
  - ISP can be used with RESET to apply hardware conditions resulting in bootloader start
  - INT0 push-button can be used to activate INT0 input
  - INT1 push-button can be used to activate INT1 input
- 2.5.2 User Push buttons** ■ PB0, PB1, PB2 and PB3 are four push-buttons available for user application
- They are made available on a 6 pins socket and in the expansion area so user can use them according to the application needs.
- 2.5.3 Indicator LEDs**
- PWR led is driven by input of voltage regulator
  - Rx led is connected to Rx of UART MCU (SP3 jumper can be soldered or not)
  - Tx led is connected to Tx of UART MCU (SP4 jumper can be soldered or not)
  - ALE led is connected to ALE of MCU
- 2.5.4 User LEDs** ■ LED0, LED1, ... LED7 are height leds available for user application
- They are made available on a 10 pins socket and in the expansion area so user can use them according to its application needs.
- 2.5.5 Ports** Port 0 and Port 2 are made available on two 10 pins sockets to ease user interconnection to the MCU.
- The are also available on the expansion area.
- 2.5.6 Clocks** An external clock can be connected to the board to control externally XTAL1 input clock of MCU by using the XTAL1 from the expansion area.
- In the same way, another external clock can be connected to control externally the PCA clock (P1.2/ECI).

---

## 2.6 Interfaces

- 2.6.1 TWI** The TWI connector is controlled by hardware TWI I/O of MCU (for Product including this feature). The signals sda and scl are controlled by the TWI ports of MCU.
- This TWI bus is also connected to the expansion area.
- External TWI pull-ups are not provided on the AT89STK-11.**
- 2.6.2 SPI** The SPI connector is directly connected to SPI I/O of the MCU.
- 2.6.3 RS-232** The DB9 connector is connected to on-chip UART peripheral through a standard RS232 driver/receiver. Two leds are provided to indicate activity on Rx and Tx lines (They can be disconnected removing solder pad SP3 and SP4).
- 2.6.4 OCD** The On-Chip Debug interface (OCD) is provided on a 6-pin connector.



This interface enables the debug of the application through ATMEL OCD dongle for AT89C51RE2/IE2/RD3/IE3 only.

## 2.6.5 Expansion Area

In addition to a 16x29 pad array, two rows of pads are given on the right side of the board to offer all the MCU signals to user application. Any application expansion can be built on board through this interface.

## 2.7 Board Settings

The C51 Demo Board has the following settings:

- Jumpers
- Solder straps
- Test points

### 2.7.1 Jumpers

The following table provides an overview of the jumpers, the solder straps and their default configuration.

**Table 2-1.** Jumpers and Switches Overview

Reference	PCB Label	Function	Default
Jumper J11	J11	RTS of RS232	OFF
Jumper J12	J12	DTR of RS232	OFF
Jumper J13	J13		OFF

**Figure 2-5.** Jumper Setting Definition

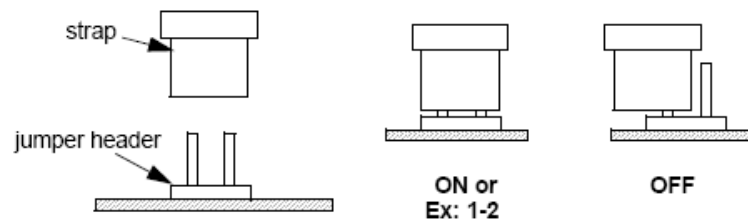

### 2.7.2 Solder Straps

Solder straps allow to modify the board configuration for specific usage.

**Table 2-2.** Solder Straps Overview

Reference	PCB Label	Function	Default
Solder strap SP1	SP1	External Power Supply Isolation	Soldered
Solder strap SP2	ICC	Consumption measurement	Soldered
Solder strap SP3	SP3	Rx Led	Soldered
Solder strap SP4	SP4	Tx Led	Soldered

**Figure 2-6.** Solder Strap Definition



### 2.7.3 Test Points

Test points are used to check the internal power supply of the microcontroller.

**Table 2-3.** Table of Test Points

Reference	PCB Label	Function
TP1	VCC	Test point for Vcc
TP2,TP3	GND	Test point for GND



## Section 3

---

# ISP Programming

The On-Chip memories and configuration bytes can be programmed using the ISP mode of the device and Atmel's FLEXible In-system Programmer Software (FLIP) described below.

- 
- |              |                            |  |
|--------------|----------------------------|--|
| <b>3.1</b>   | <b>Manual ISP Mode</b>     | See Section "FLIP Software", page 11.  |
| <b>3.1.1</b> | <b>Board Configuration</b> | To use ISP mode, no specific configuration is necessary on the board. Only make sure that the EA pin of the product is tied to Vcc (internal code execution only).   |
| <b>3.1.2</b> | <b>Operating Mode</b>      | To enter in ISP mode, press both the RESET and ISP buttons simultaneously.<br>First release the RESET button and then the ISP button. The device enters in ISP mode. |
- 
- |              |                            |   |
|--------------|----------------------------|---|
| <b>3.2</b>   | <b>Auto ISP Mode</b>       | It allows the host PC application (Atmel Flip software for example) to control the hardware conditions from the serial lines RTS and DTR.<br>Thus with the Auto ISP mode, the user does not need to push the ISP and RESET buttons. |
| <b>3.2.1</b> | <b>Board Configuration</b> | To use Auto ISP mode, put the board in the same configuration as ISP mode and also: <ul style="list-style-type: none"><li>■ Close RTS (J11) jumper</li><li>■ Close DTR (J12) jumper</li></ul>                                       |

---

**3.3 FLIP Software** FLIP software runs on Windows® and Linux® Operating Systems. FLIP supports in-system programming of Flash C51 devices through RS232. The latest version of FLIP software can be downloaded from the Atmel web site, [www.atmel.com](http://www.atmel.com).

---

**3.4 Batchisp Software** Batchisp is an In-System Programming application which can perform the same operations as FLIP but is designed to be launched from the DOS command window.

The main purpose of batchisp is to automate ISP operations on several parts. It may also be launched from an IDE like Keil's uVision®2 one : you can compile and link your embedded program, generate the HEX file and download it to the target hardware without leaving the Keil's IDE. This makes embedded software development and test faster.

Autoisp function is an operation which allows to enter in ISP mode without any hardware handling. This is done thanks to DTR and RTS RS232 signals which can control on the Board the RST and PSEN I/O of MCU.

## Appendix A: Board Layout

Figure 4-1. Board Components View Diagram

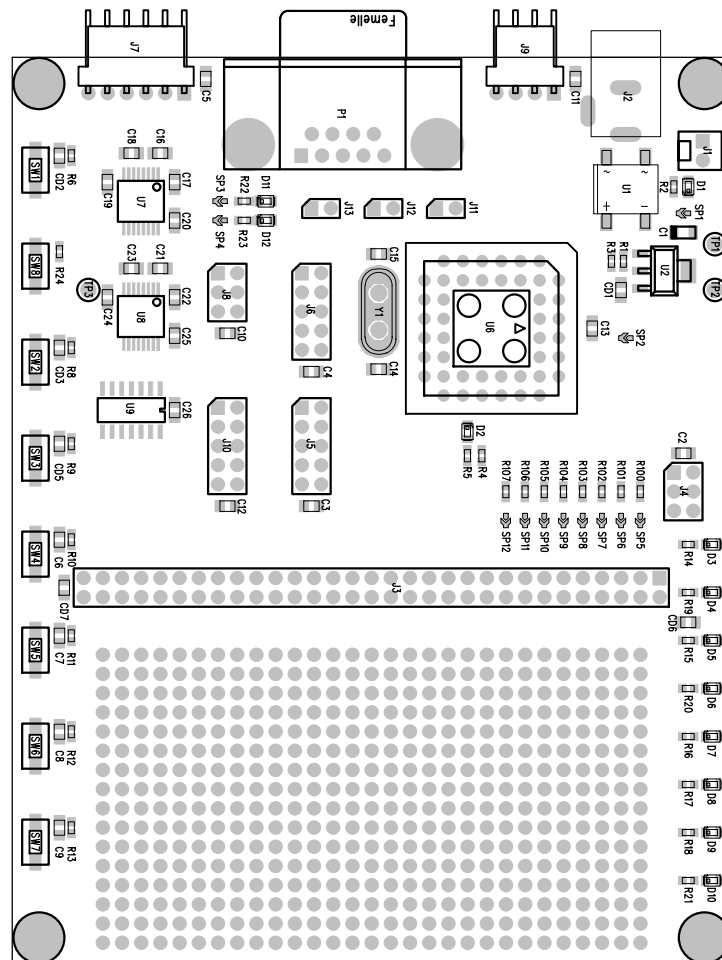



## Appendix B: Bill of Materials

### 4.1 Bill of Materials Table

Item	Qty	Reference	Part	Tech. Characteristics	Package	Manufacturer
1	29	CD1,CD2,C2,CD3,C3,C4,	100n	50V-10% Ceramic	CASE 0805	PHYCOMP
		CD5,C5,CD6,C6,CD7,C7,C8,				
		C9,C10,C11,C12,C13,C16,				
		C17,C18,C19,C20,C21,C22,				
		C23,C24,C25,C26				
2	1	C1	1 $\mu$ F	10Vmin $\pm$ 10%	Case A	AVX
3	2	C14,C15	22pF	10Vmin $\pm$ 10%	EIA/IECQ 3216	PHYCOMP
4	1	D1	Red Led	I=10 mA		Agilent <sup>®</sup>
5	11	D2,D3,D4,D5,D6,D7,D8,D9, D10,D11,D12	Green Led	I=10 mA		Agilent
6	1	J1	SIP2 SOCKET		Pitch 2.54mm	Molex <sup>®</sup>
7	1	J2	CONNECTOR JACK PWR	Int.Diam=2.1mm	Int. Diam. 2.1mm	Cliff <sup>®</sup>
8	1	J3	HEADER 31x2/SM			
9	2	J4,J8	HEADER 3X2	BARRETTE SECABLE	Pitch 2.54mm	Tyco Elec. / AMP
10	3	J5,J6,J10	HEADER 5X2	BARRETTE SECABLE	Pitch 2.54mm	Tyco Elec. / AMP
11	1	J7	CONNECTOR SIP6 RA			
12	1	J9	SIP4			
13	3	J11,J12,J13	JUMPER		Pitch 2.54mm	Tyco <sup>™</sup> Elec. / AMP
13bis	3		JUMPER shunt		Pitch 2.54mm	Arwin
14	1	P1	SUB-D9 FEMALE	90° with harpoons		Tyco Elec. / AMP
15	1	R1	270	1/16W-5% SMD	Case 0603	Multicomp
16	14	R2,R5,R14,R15,R16,R17,	1K	0.06W, 5%	Case 0603	Multicomp
		R18,R19,R20,R21,R22,R23,				
		R24				
17	1	R3	820	1/16W-5% SMD	Case 0603	Multicomp
18	8	R4,R6,R8,R9,R10,R11,R12, R13	10k	0.06W, 5%	Case 0603	Multicomp
19	4	SP1,SP2,SP3,SP4,SP5, SP6, SP7, SP8, SP9, SP10, SP11, SP12	SolderPad			
20	8	SW1,SW2,SW3,SW4,SW5,SW6, SW7,SW8	PUSH-BUTTON	SMD, rectangular	See DS	ITT Canon <sup>®</sup>

Item	Q.ty	Reference	Part	Tech. Characteristics	Package	Manufacturer
21	3	TP1,TP2,TP3	TEST POINT	Through Hole Pad	Hole 1.1mm	Vero
22	1	U1	DF005S		TO269AA	Vishay®
23	1	U2	LM317		SOT-223	National®
25	1	U6	AT8xC51_PLCC44	Socket		
25bis	1	U6	AT8xC51_PLCC44			
26	2	U7,U8	SIPEX-SP3232ECA	Ref=SP3232ECA	SSOP16	Maxim®
27	1	U9	74HC125/SO		SOIC	texas
28	1	Y1	CRYSTAL	HC49		
28bis	2	Y1	CRYSTAL tulip			
29	8	R100, R101, R102, R103, R104, R105, R106, R107	4,7K	0.06W, 5%	Case 0603	Multicomp



## Appendix C: Board Schematics



Figure 4-2. AT89STK-11 Schematics (1 of 4)

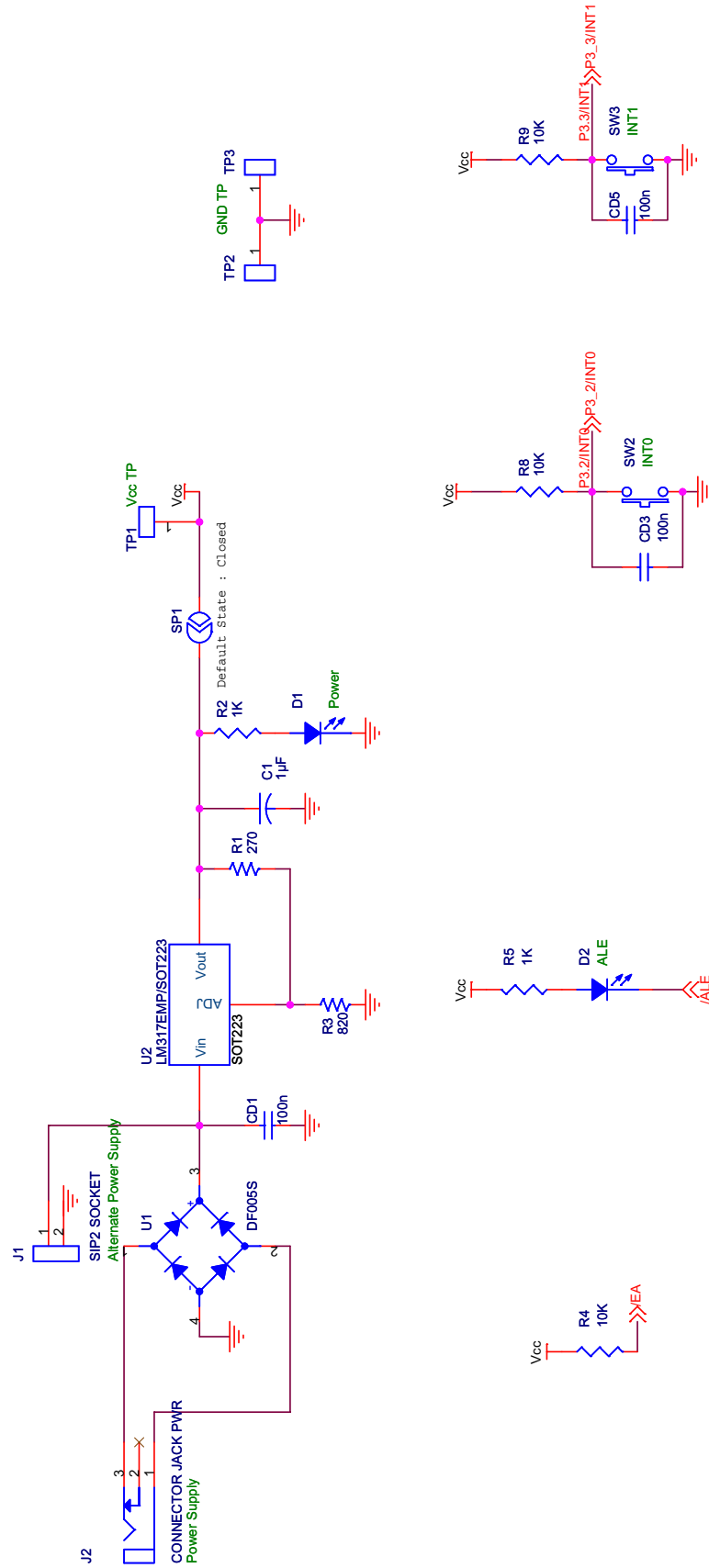

Figure 4-3. AT89STK-11 Schematics (2 of 4)

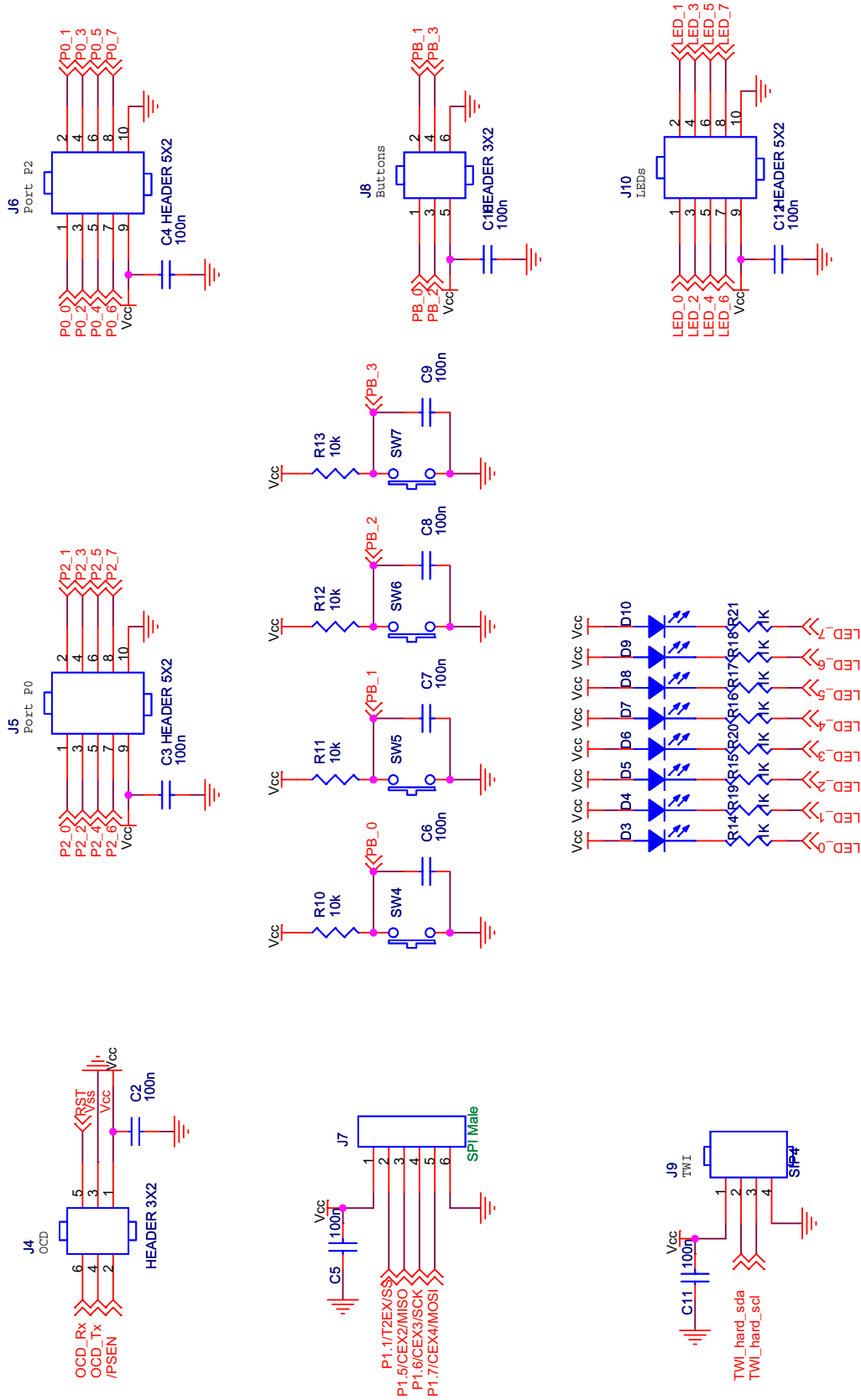
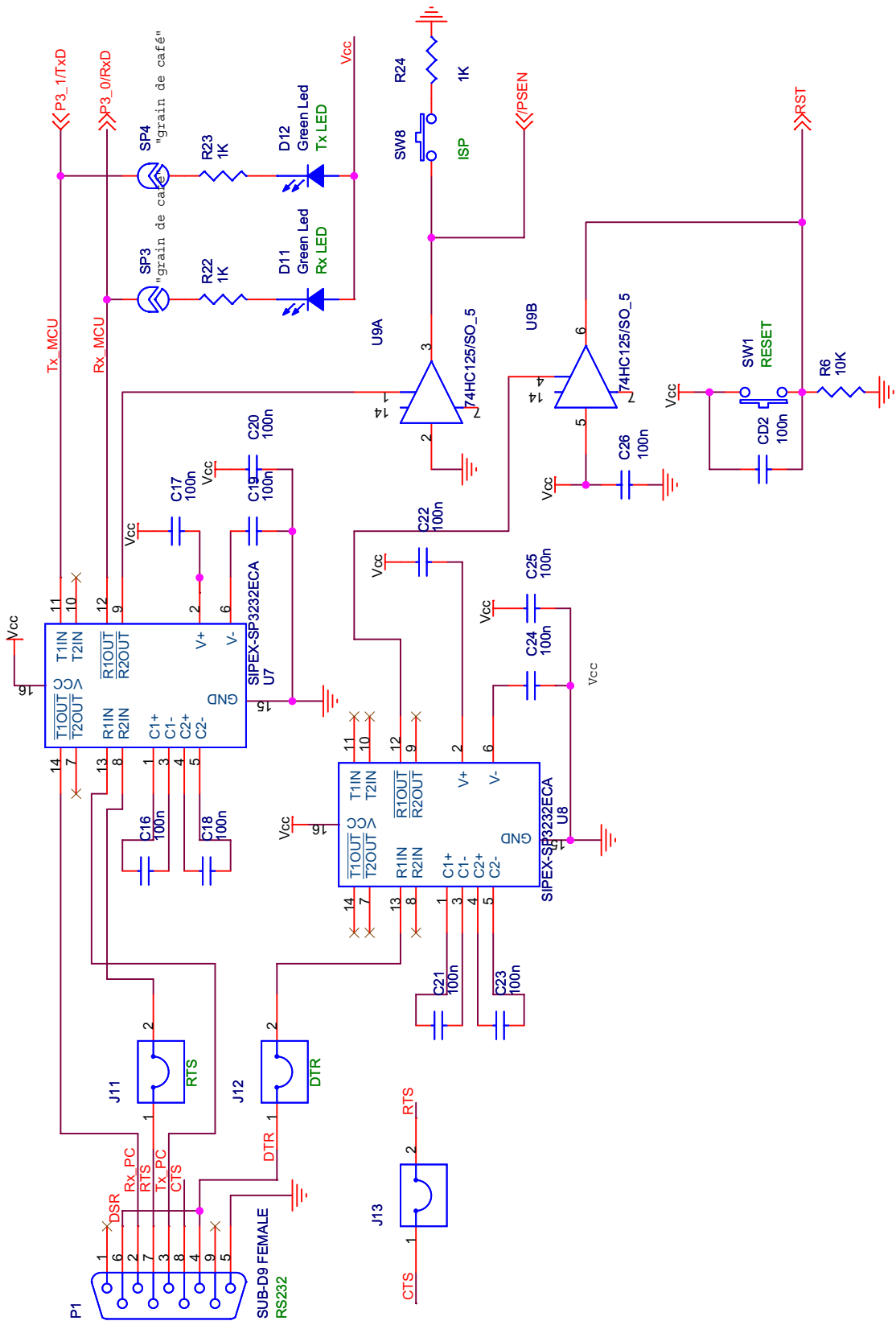



Figure 4-5. AT89STK-11 Schematics (4 of 4)





## Appendix D: References/Acronyms

- 
- 4.2 References**
- AT89C51RD2/ID2/ED2/RB2/RC2/IC2/RE2/IE2 and AT89C51RD3/IE3 Product Datasheet.
- 
- 4.3 Acronyms**
- FLIP: FLexible In-system Programming
  - ISP: In-System programming

## Document Revision History

### Changes from 7676A to 7676B

1. Section 1.2, page 1-2 : AT89C51RE3/ID3/IE2 not supported.
2. Section 2.3.1.2, page 2-5 : SP1 must be kept closed.
3. Section 3.1.1, page 3-11 : SW1 switch and EA jumper do not exist.
4. Appendix A, page 4-13 : the given board layout was wrong. Replaced by the right one.
5. Appendix C, page 4-19 : there was an error on page 4 of the schematic. Pin5 of U9B is now connected to Vcc instead of GND.



## Atmel Corporation

2325 Orchard Parkway  
San Jose, CA 95131, USA  
Tel: 1(408) 441-0311  
Fax: 1(408) 487-2600

## Regional Headquarters

### Europe

Atmel Sarl  
Route des Arsenalux 41  
Case Postale 80  
CH-1705 Fribourg  
Switzerland  
Tel: (41) 26-426-5555  
Fax: (41) 26-426-5500

### Asia

Room 1219  
Chinachem Golden Plaza  
77 Mody Road Tsimshatsui  
East Kowloon  
Hong Kong  
Tel: (852) 2721-9778  
Fax: (852) 2722-1369

### Japan

9F, Tonetsu Shinkawa Bldg.  
1-24-8 Shinkawa  
Chuo-ku, Tokyo 104-0033  
Japan  
Tel: (81) 3-3523-3551  
Fax: (81) 3-3523-7581

## Atmel Operations

### Memory

2325 Orchard Parkway  
San Jose, CA 95131, USA  
Tel: 1(408) 441-0311  
Fax: 1(408) 436-4314

### Microcontrollers

2325 Orchard Parkway  
San Jose, CA 95131, USA  
Tel: 1(408) 441-0311  
Fax: 1(408) 436-4314

La Chantrerie  
BP 70602  
44306 Nantes Cedex 3, France  
Tel: (33) 2-40-18-18-18  
Fax: (33) 2-40-18-19-60

### ASIC/ASSP/Smart Cards

Zone Industrielle  
13106 Rousset Cedex, France  
Tel: (33) 4-42-53-60-00  
Fax: (33) 4-42-53-60-01

1150 East Cheyenne Mtn. Blvd.  
Colorado Springs, CO 80906, USA  
Tel: 1(719) 576-3300  
Fax: 1(719) 540-1759

Scottish Enterprise Technology Park  
Maxwell Building  
East Kilbride G75 0QR, Scotland  
Tel: (44) 1355-803-000  
Fax: (44) 1355-242-743

### RF/Automotive

Theresienstrasse 2  
Postfach 3535  
74025 Heilbronn, Germany  
Tel: (49) 71-31-67-0  
Fax: (49) 71-31-67-2340

1150 East Cheyenne Mtn. Blvd.  
Colorado Springs, CO 80906, USA  
Tel: 1(719) 576-3300  
Fax: 1(719) 540-1759

### Biometrics/Imaging/Hi-Rel MPU/ High Speed Converters/RF Datacom

Avenue de Rochepleine  
BP 123  
38521 Saint-Egreve Cedex, France  
Tel: (33) 4-76-58-30-00  
Fax: (33) 4-76-58-34-80

---

### Literature Requests

[www.atmel.com/literature](http://www.atmel.com/literature)

**Disclaimer:** The information in this document is provided in connection with Atmel products. No license, express or implied, by estoppel or otherwise, to any intellectual property right is granted by this document or in connection with the sale of Atmel products. **EXCEPT AS SET FORTH IN ATMEL'S TERMS AND CONDITIONS OF SALE LOCATED ON ATMEL'S WEB SITE, ATMEL ASSUMES NO LIABILITY WHATSOEVER AND DISCLAIMS ANY EXPRESS, IMPLIED OR STATUTORY WARRANTY RELATING TO ITS PRODUCTS INCLUDING, BUT NOT LIMITED TO, THE IMPLIED WARRANTY OF MERCHANTABILITY, FITNESS FOR A PARTICULAR PURPOSE, OR NON-INFRINGEMENT. IN NO EVENT SHALL ATMEL BE LIABLE FOR ANY DIRECT, INDIRECT, CONSEQUENTIAL, PUNITIVE, SPECIAL OR INCIDENTAL DAMAGES (INCLUDING, WITHOUT LIMITATION, DAMAGES FOR LOSS OF PROFITS, BUSINESS INTERRUPTION, OR LOSS OF INFORMATION) ARISING OUT OF THE USE OR INABILITY TO USE THIS DOCUMENT, EVEN IF ATMEL HAS BEEN ADVISED OF THE POSSIBILITY OF SUCH DAMAGES.** Atmel makes no representations or warranties with respect to the accuracy or completeness of the contents of this document and reserves the right to make changes to specifications and product descriptions at any time without notice. Atmel does not make any commitment to update the information contained herein. Unless specifically provided otherwise, Atmel products are not suitable for, and shall not be used in, automotive applications. Atmel's Atmel's products are not intended, authorized, or warranted for use as components in applications intended to support or sustain life.

© Atmel Corporation 2007. All rights reserved. Atmel®, logo and combinations thereof, are registered trademarks, and Everywhere You Are® are the trademarks of Atmel Corporation or its subsidiaries. Other terms and product names may be trademarks of others.