

NOTES

- MATERIAL
 HOUSING LCP UL94V-0 (NATURAL)
 ACTUATOR LCP UL94V-0 (BLACK)
 TERMINAL PHOSPHOR BRONZE
 FITTING NAIL PHOSPHOR BRONZE
- PLATING
 TERMINAL : SELECTIVE GOLD[Au] OVER NICKEL[Ni] PLATING.
 CONTACT AREA : GOLD[Au] 0.1 MICROMETER MIN. OVER NICKEL[Ni] 1.0~3.0 MICROMETER(UNDER PLATING)
 SOLDER AREA : GOLD[Au] 0.05 MICROMETER MIN. OVER NICKEL[Ni] 1.0~3.0 MICROMETER(UNDER PLATING)
 FITTING NAIL : TIN[Sn] OVER NICKEL[Ni] PLATING.
 Tin[Sn] 1~3 MICROMETER.
 NICKEL[Ni] 1~3 MICROMETER (UNDER PLATING)
- PRODUCT SPECIFICATION : PS-104184-001
 PACKING SPECIFICATION : PK-104184-001
- ACTUATOR IS CLOSED IN THE EMBOSSED PACKING
- COPLANARITY IS AFTER REFLOW 0.1MAX.

REVISED	EC NO: KOR2015-0076	2014/12/17	QUALITY SYMBOLS
	DRWN:YRK/IM	2014/12/17	
	CHKD:KSK/IM	2014/12/17	
	APPR:YSK/IM02	2015/03/09	
B	DESCRIPTION		

GENERAL TOLERANCES (UNLESS SPECIFIED)	
	mm INCH
4 PLACES	± --- ± ---
3 PLACES	± 0.005 ± ---
2 PLACES	± 0.05 ± ---
1 PLACE	± 0.1 ± ---
ANGULAR ± 1 °	
DRAFT WHERE APPLICABLE MUST REMAIN WITHIN DIMENSIONS	

DIMENSION STYLE	
MM ONLY	
DRAWN BY	DATE
YRK/IM	2014/10/01
CHECKED BY	DATE
KSK/IM	2014/10/01
APPROVED BY	DATE
YSK/IM02	2014/10/02
MATERIAL NO.	
SEE TABLE	
SIZE	
A3	

SCALE	DESIGN UNITS	THIRD ANGLE PROJECTION
20:1	METRIC	☉ □
TITLE		
0.5 FFC CONN EASY-ON R/A SMT HSG ASS'Y (H=2.0MM)		
molex		
MATERIAL NO.	DOCUMENT NO.	SHEET NO.
	SD-104184-001	1 OF 3

38.88	34.55	37.0	33.5	104184-6817	68
29.88	25.55	28.0	24.5	104184-5017	50
D	C	B	A	ORDER No.	Ckt

10 9 8 7 6 5 4 3 2 1

APPLICABLE FFC
RECOMMENDED DIMENSION

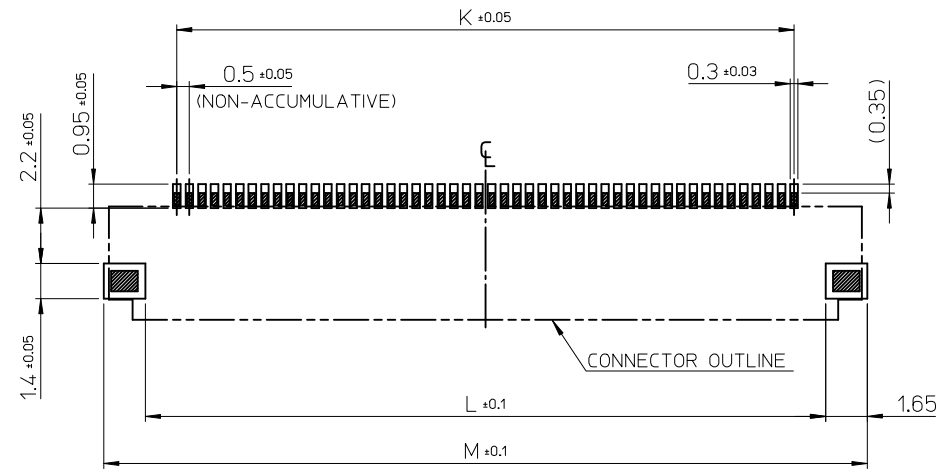
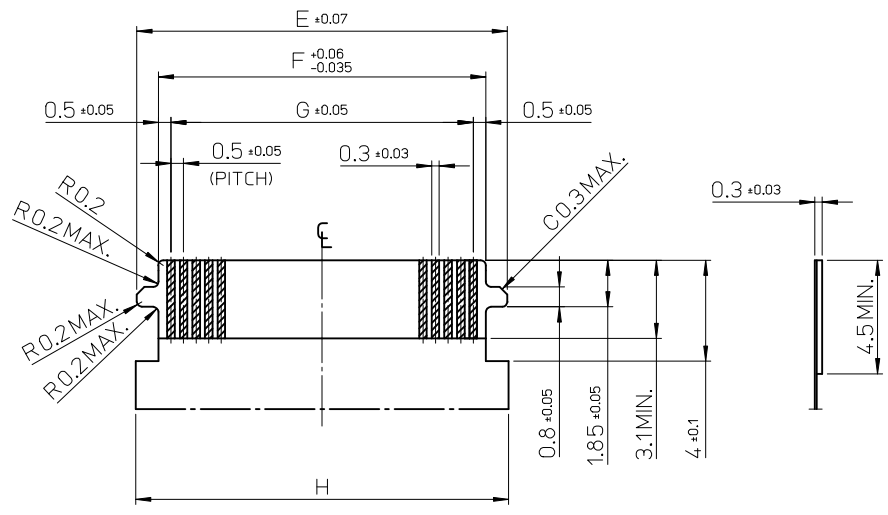

P.C.BOARD PATTERN
DIMENSION (REF.)
(MOUNTING SIDE)

RECOMMEND METAL MASK THICKNESS : t=0.15

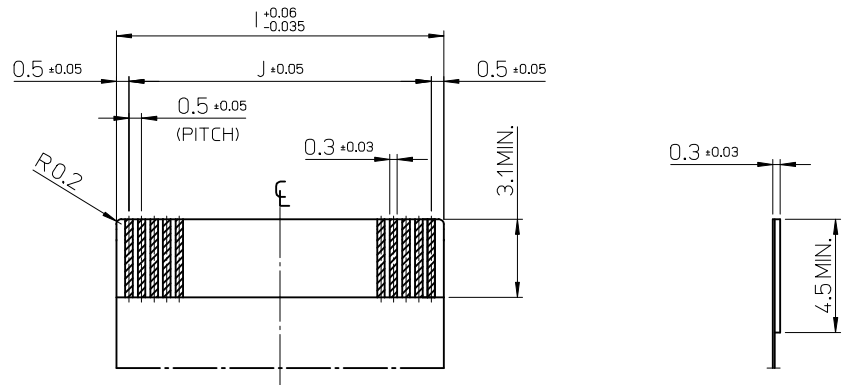

STIFFENER SIDE

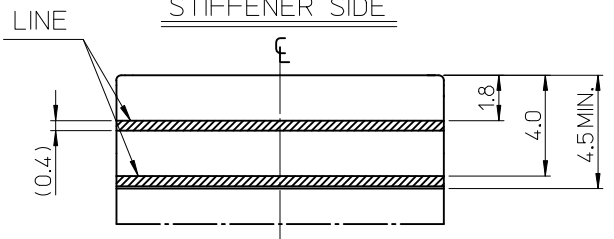

39.3	36	33.5	33.5	34.5	36.3	33.5	34.5	36.2	104184-6817	68
30.3	27	24.5	24.5	25.5	27.3	24.5	25.5	27.2	104184-5017	50
M	L	K	J	I	H	G	F	E	ORDER No.	Ckt

REVISED EC NO: KOR2015-0076 DRWN:YRKIM 2014/12/17 CHKD:KSKIM 2014/12/17 APPR:YSKIM02 2015/03/09	QUALITY SYMBOLS	GENERAL TOLERANCES (UNLESS SPECIFIED)	DIMENSION STYLE	SCALE	DESIGN UNITS	THIRD ANGLE PROJECTION
	▽=0 ◻=0	mm INCH 4 PLACES ± --- ± --- 3 PLACES ± 0.005 ± --- 2 PLACES ± 0.05 ± --- 1 PLACE ± 0.1 ± --- ANGULAR ± 1°	MM ONLY	20:1	METRIC	DRAWN BY: YRKIM DATE: 2014/10/01 CHECKED BY: KSKIM DATE: 2014/10/01 APPROVED BY: YSKIM02 DATE: 2014/10/02
	DRAFT WHERE APPLICABLE MUST REMAIN WITHIN DIMENSIONS	SEE SHEET 1	TITLE		0.5 FFC CONN EASY-ON R/A SMT HSG ASS'Y (H=2.0MM)	
		SIZE A3	MATERIAL NO.	DOCUMENT NO.	SHEET NO. 2 OF 3	



9 8 7 6 5 4 3 2 1

DIRECTION OF PULLING OUT

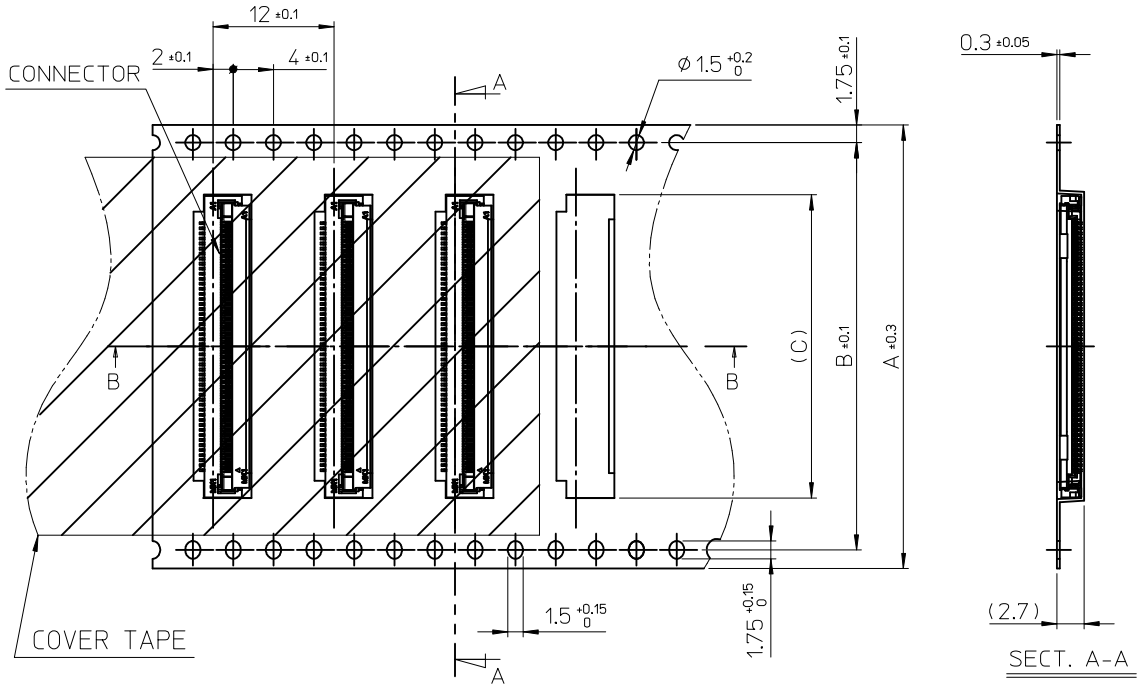

NOTES

- 1. QUANTITY OF CONNECTORS : 3000PCS/REEL
- 2. LEAD LENGTH

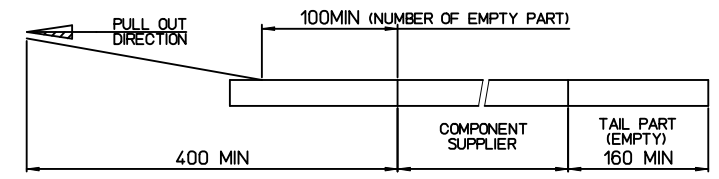

- 3. THIS PRODUCT IS HALOGEN FREE (LV.2)
- 4. PEELING OFF FORCE OF COVER TAPE : 10~60GF
(PEELING DIRECTION AS SHOW IN FOLLOW FIG.)
PEELING OFF SPEED : 300MM/MIN.(Ref.)

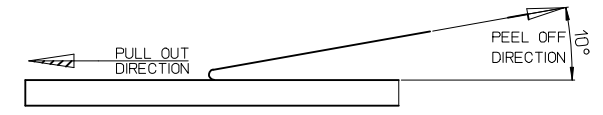

DIRECTION OF PULLING OUT

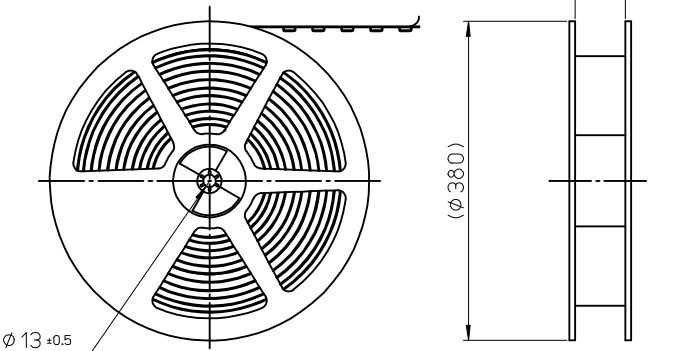

PLASTIC BOBBIN

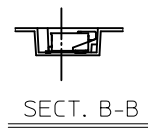

REVISED	EC NO: KOR2015-0076	2014/12/17	QUALITY SYMBOLS
	DRWN:YRKIM	2014/12/17	
B	CHKD:KSKIM	2014/12/17	▽=0
	APPR:YSKIM02	2015/03/09	∇=0

GENERAL TOLERANCES (UNLESS SPECIFIED)	mm	INCH	
	4 PLACES	± 0.005	± 0.0002
DRAFT WHERE APPLICABLE MUST REMAIN WITHIN DIMENSIONS	3 PLACES	± 0.005	± 0.0002
	2 PLACES	± 0.05	± 0.002
	1 PLACE	± 0.1	± 0.008
	ANGULAR ± 1 °		

DIMENSION STYLE		SCALE	DESIGN UNITS	THIRD ANGLE PROJECTION
MM ONLY		20:1	METRIC	☉
DRAWN BY	DATE	TITLE		
YRKIM	2014/10/01	0.5 FFC CONN EASY-ON R/A		
CHECKED BY	DATE	SMT HSG ASS'Y		
KSKIM	2014/10/01	(H=2.0MM)		
APPROVED BY	DATE			
YSKIM02	2014/10/02			
MATERIAL NO.	DOCUMENT NO.	SHEET NO.		
SEE SHEET1	SD-104184-001	3 OF 3		

57.5	39.08	52.4	56	104184-6817	68
44.5	30.08	40.4	44	104184-5017	50
D	C	B	A	ORDER No.	Ckt