

Silicon Power Schottky Diode

$V_{RRM} = 20\text{ V} - 40\text{ V}$

$I_{F(AV)} = 40\text{ A}$

Features

- High Surge Capability
- Types from 20 V to 40V V_{RRM}
- Not ESD Sensitive

Note:

1. Standard polarity: Stud is cathode.
2. Reverse polarity (R): Stud is anode.
3. Stud is base.

DO-5 Package

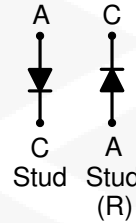

Maximum ratings, at $T_j = 25\text{ °C}$, unless otherwise specified ("R" devices have leads reversed)

| Parameter | Symbol | Conditions | 1N5832 (R) | 1N5833 (R) | 1N5834 (R) | Unit |
|---------------------------------|-----------|------------|------------|------------|------------|------|
| Repetitive peak reverse voltage | V_{RRM} | | 20 | 30 | 40 | V |
| RMS reverse voltage | V_{RMS} | | 14 | 21 | 28 | V |
| DC blocking voltage | V_{DC} | | 20 | 30 | 40 | V |
| Operating temperature | T_j | | -55 to 150 | -55 to 150 | -55 to 150 | °C |
| Storage temperature | T_{stg} | | -55 to 150 | -55 to 150 | -55 to 150 | °C |

Electrical characteristics, at $T_j = 25\text{ °C}$, unless otherwise specified

| Parameter | Symbol | Conditions | 1N5832 (R) | 1N5833 (R) | 1N5834 (R) | Unit |
|--|-------------|--|------------|------------|------------|------|
| Average forward current (per pkg) | $I_{F(AV)}$ | $T_C = 125\text{ °C}$ | 40 | 40 | 40 | A |
| Peak forward surge current (per leg) | I_{FSM} | $t_p = 8.3\text{ ms}$, half sine | 800 | 800 | 800 | A |
| Maximum instantaneous forward voltage (per leg) | V_F | $I_F = 40\text{ A}$, $T_j = 25\text{ °C}$ | 0.70 | 0.70 | 0.70 | V |
| Maximum instantaneous reverse current at rated DC blocking voltage (per leg) | I_R | $T_j = 25\text{ °C}$ | 1 | 1 | 1 | mA |
| | | $T_j = 100\text{ °C}$ | 10 | 10 | 10 | |
| | | $T_j = 150\text{ °C}$ | 20 | 20 | 20 | |

Thermal characteristics

| | | | | | | |
|---|-----------------------|--|------|------|------|------|
| Maximum thermal resistance, junction - case (per leg) | $R_{\theta JC}$ | | 1.45 | 1.45 | 1.45 | °C/W |
| Mounting torque | Inch ponds (in-pb) | | 30 | 30 | 30 | |

Figure .1- Typical Forward Characteristic

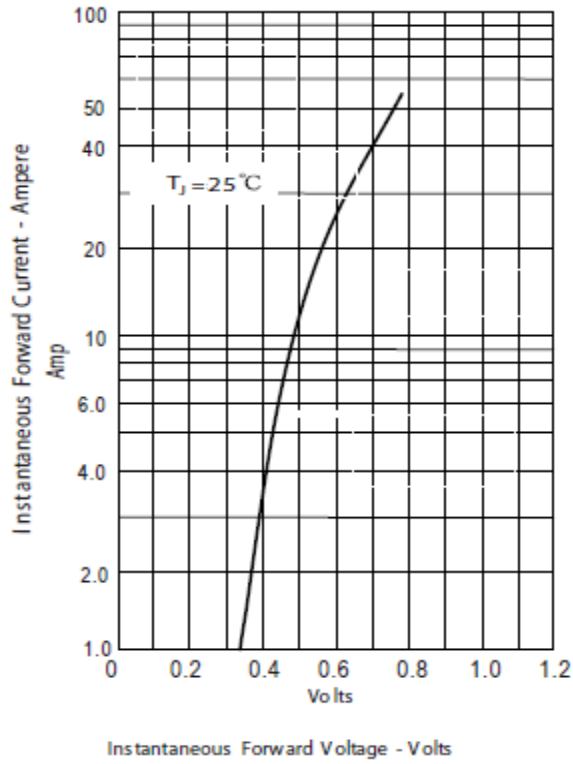

Figure .2- Forward Derating Curve

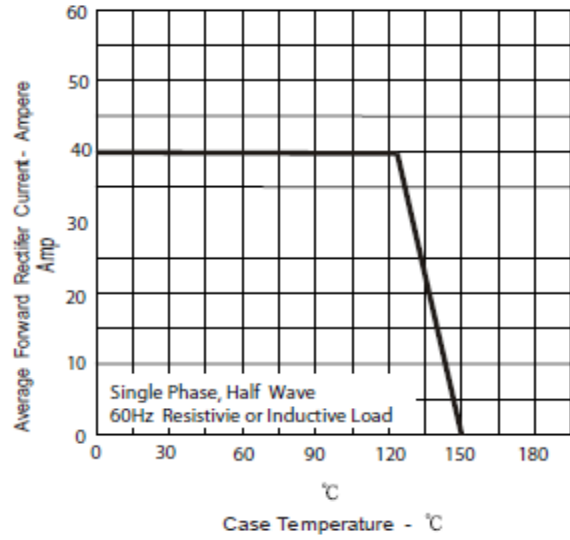

Figure .4- Typical Reverse Characteristics

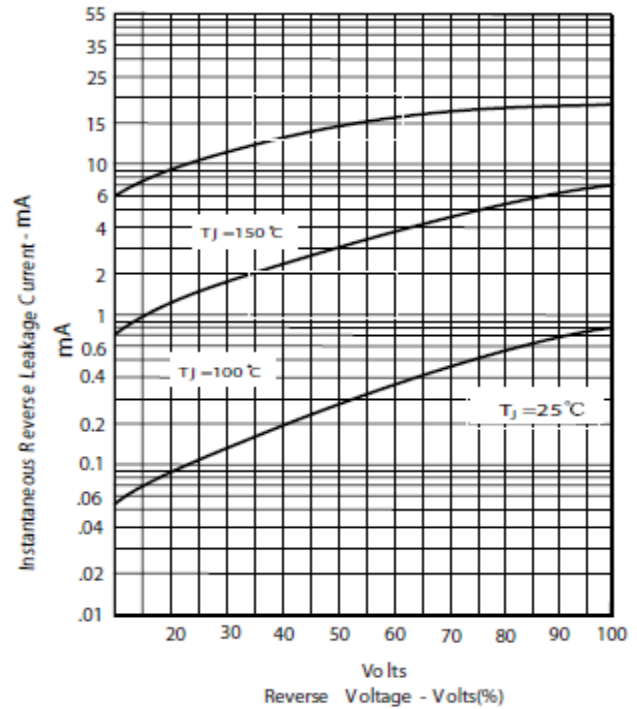
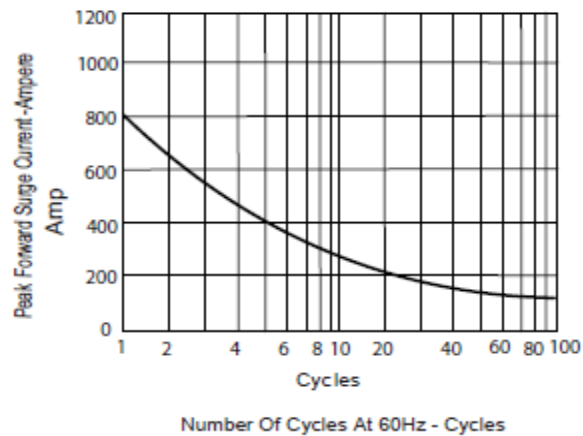
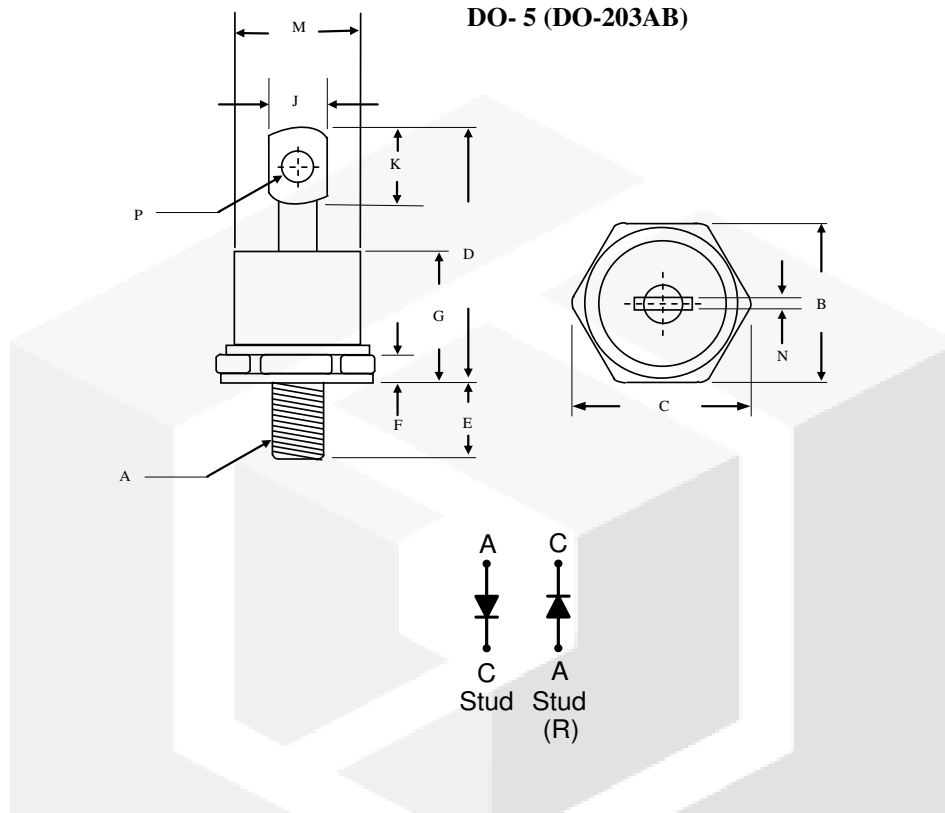

Figure.3-Peak Forward Surge Current



Package dimensions and terminal configuration

Product is marked with part number and terminal configuration.



| | Inches | | Millimeters | |
|---|------------|-------|-------------|-------|
| | Min | Max | Min | Max |
| A | 1/4-28 UNF | | | |
| B | 0.669 | 0.687 | 17.19 | 17.44 |
| C | ----- | 0.794 | ----- | 20.16 |
| D | ----- | 1.020 | ----- | 25.91 |
| E | 0.422 | 0.453 | 10.72 | 11.50 |
| F | 0.115 | 0.200 | 2.93 | 5.08 |
| G | ----- | 0.460 | ----- | 11.68 |
| J | ----- | 0.280 | ----- | 7.00 |
| K | 0.236 | ----- | 6.00 | ----- |
| M | ----- | 0.589 | ----- | 14.96 |
| N | ----- | 0.063 | ----- | 1.60 |
| P | 0.140 | 0.175 | 3.56 | 4.45 |