

APPROVED: _____
 DATE: _____ TITLE: _____

Rev	AWO #	Description	Date	Appr
-		RELEASED	11/1/22	
A		UPDATE SPEC.	11/30/22	JJ/RC

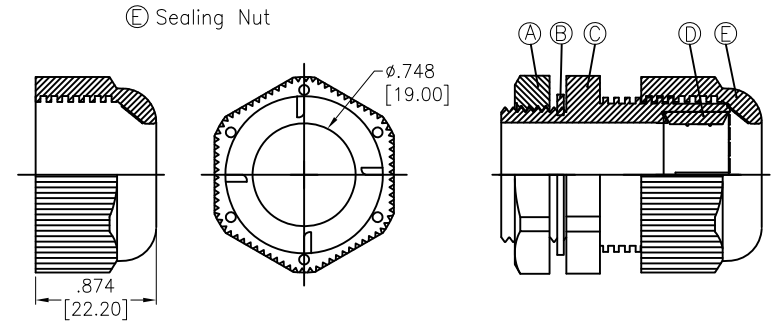
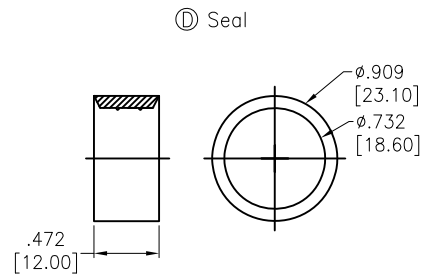
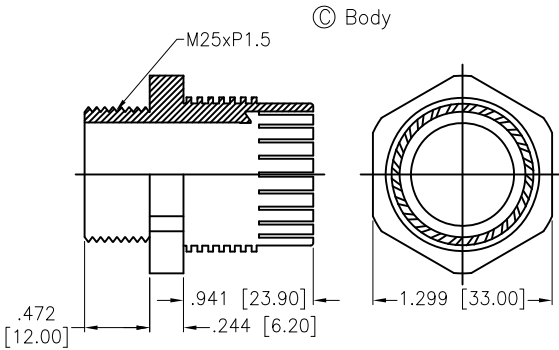
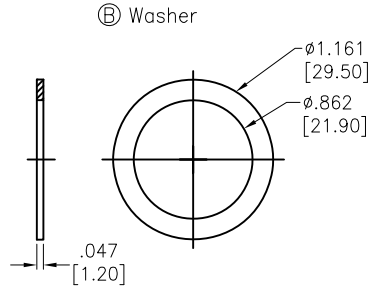
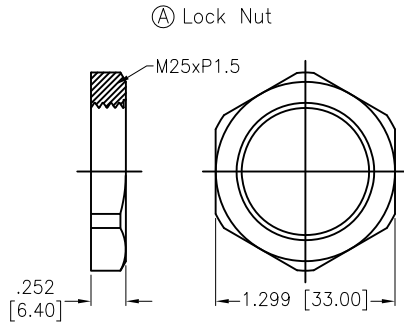

RECOMMENDED
 PANEL CUT-OUT
 (.173 [4.4] MAX PANEL THICKNESS)

SPECIFICATIONS:

Material:
 Lock Nut: PA66, rated UL 94V-2
 Body: PA66, rated UL 94V-2
 Sealing Nut: PA66, rated UL 94V-2
 Washer: Nitrile Butylene
 Seal: Nitrile Butylene
 Mechanical:
 Cable range O.D.: $\phi 0.512 \sim \phi 0.709$ [13.00~18.00mm]
 Nut Torque: 3Nm Max.
 Environmental:
 Waterproof: IP68
 Lead free, RoHS compliant.



UNLESS OTHERWISE SPECIFIED ALL DIMENSIONS ARE INCHES [MM]. TOLERANCES: EXCEPT AS NOTED		
INCHES	HOLES	
.X ± .10	ØX ± .10	
.XX ± .020	ØXX ± .015	
.XXX ± .015	ØXXX ± .010	



909 Rahway Avenue,
 Union, NJ 07083
 Phone: 908-687-5000
 Fax: 908-687-5710

DRAWN	LH	11/1/22
CHECKED	RC	11/1/22
APPROVED		
THIS DRAWING CONTAINS INFORMATION THAT IS PROPRIETARY AND SHOULD NOT BE USED WITHOUT PRIOR WRITTEN PERMISSION FROM ADAM TECH		

TITLE		
WATERPROOF CONNECTOR, M25, 1 HOLE, CABLE GLAND, WATERPROOF: IP68		
SIZE	PART NO.	REV.
X	CG-P-M25	A
REF: S00211C	SCALE: NTS	SHEET 1 OF 1