

COMMENT:  
 ALL RIGHTS ARE RESERVED BY US FOR THIS DRAWING. WITHOUT OUR PRIOR CONSENT,  
 IT MAY NEITHER BE DUPLICATED NOR MADE AVAILABLE TO A THIRD PARTY,  
 AND IT ALSO MAY NOT BE IMPROPERLY USED BY THE RECEIVER, OR A THIRD PARTY.

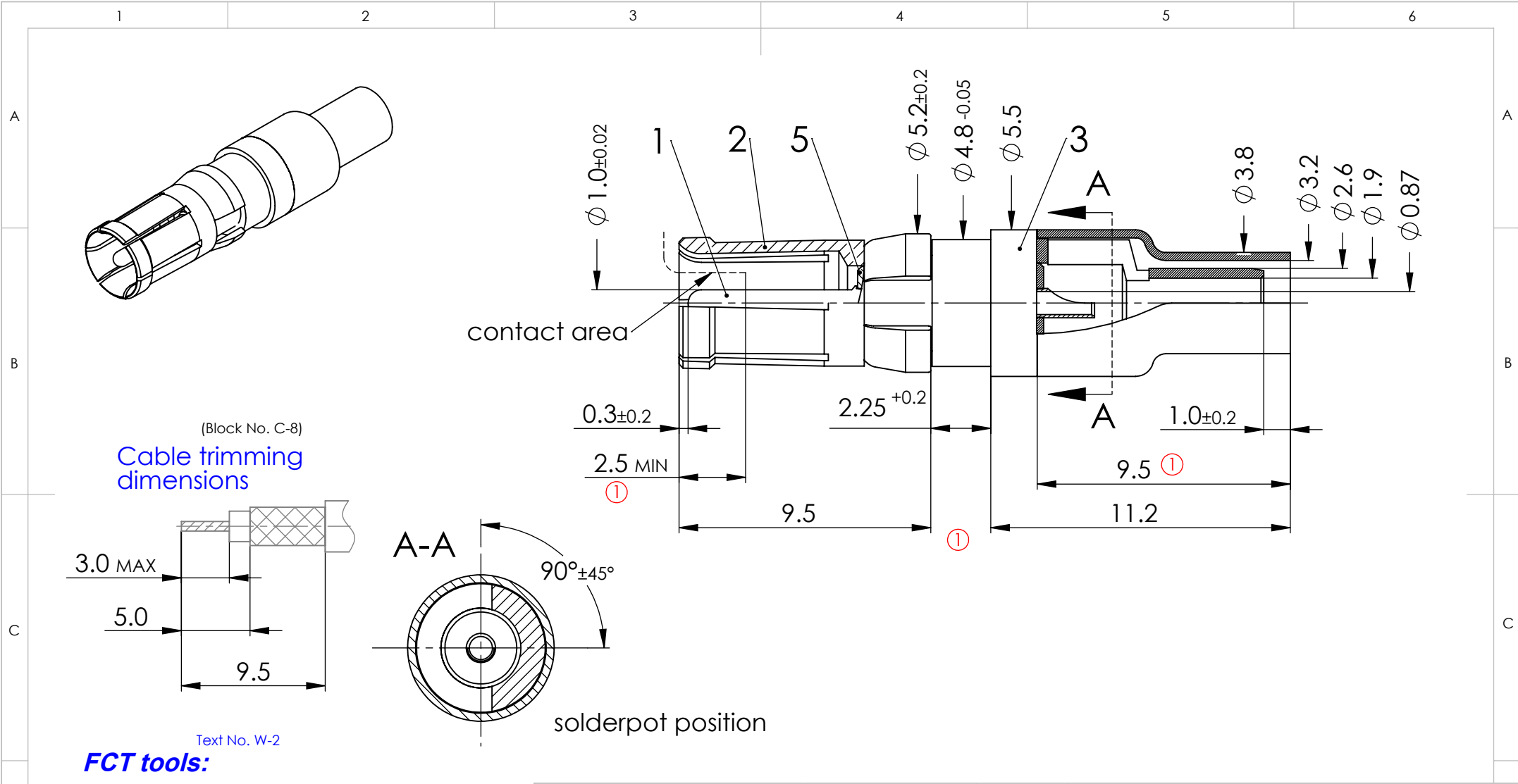

(Block No. C-8)  
**Cable trimming dimensions**

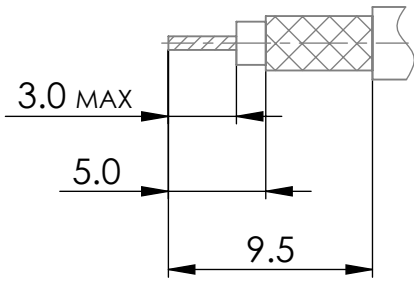

Text No. W-2

**FCT tools:**

Crimping of outer conductor:

Hand tool: M22520/5-01  
 Die: Y1535P cavity B

Pneumatic crimp tool: HX23  
 (replacement for PH4001) ②

Extraction tool: DRK38

IMPEDANCE		50 Ohm	COAXIAL CONTACT	SCALE 5:1	CABLE RG174U, RG188AU, RG316U	
FOR		D-SUB			DATA SHEET	
DIMENSIONS IN MM			DRAWN	NAME / DATE ffuhrmann 07-07-2006	PART NO. FMX006S	
MATERIAL + FINISH SEE EXTRA SHEET			CHECKED	sschref 24-10-2012	REV. 2	
UNLESS OTHERWISE SPECIFIED DIMENSIONS FOR REFERENCE ONLY					REPLACEMENT FOR:	
2	17-10-2012	23305			ORIGINAL: DIN A4-DRAWING AS A FILE	
REV.	DATE	INDEX				