

LOC	DIST	REVISIONS			
REV	DATE	DESCRIPTION	DATE	BY	APP'D
0	30SEP2004	REV PER EC 0512-0235-04	30SEP2004	BC	RW
A	10JUL2006	REVISED PER ECO-08-008615	10JUL2006	DH	DB

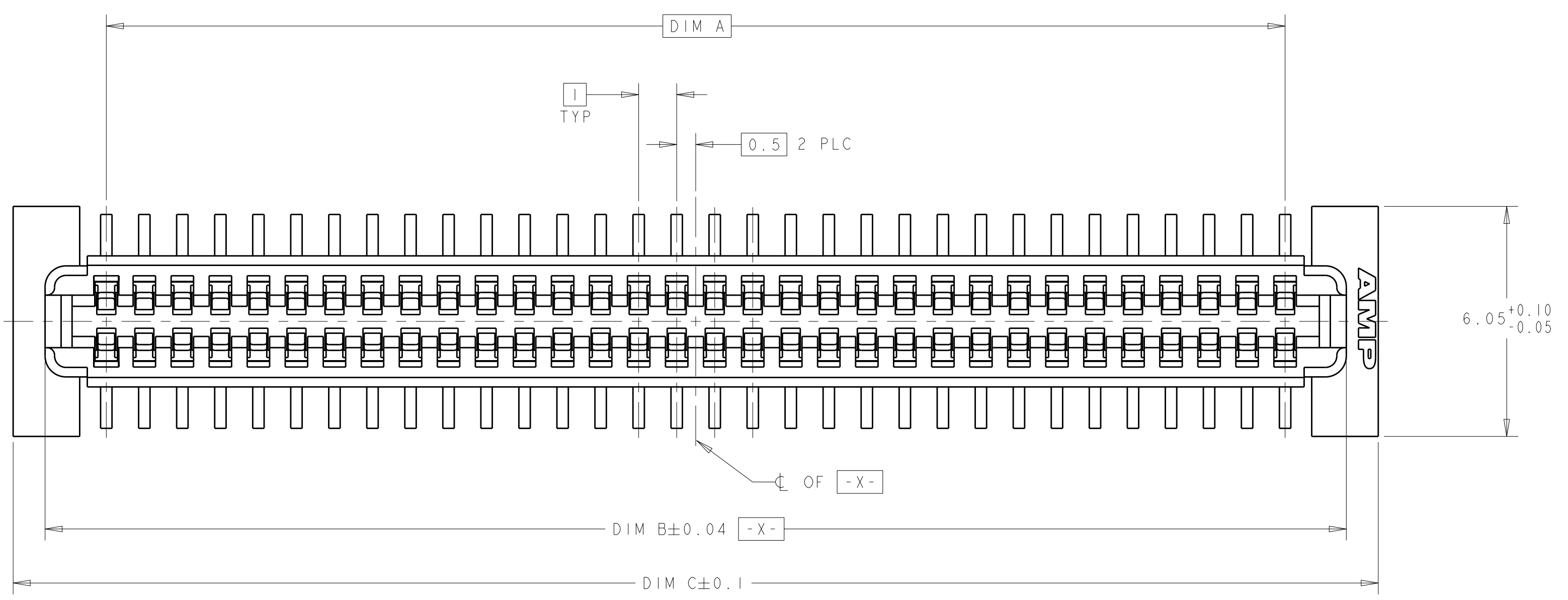

- 1. HOUSING MATERIAL: HIGH TEMPERATURE THERMOPLASTIC, COLOR: BLACK. CONTACT MATERIAL: PHOSPHOR BRONZE.
- 2. CONTACT FINISH: NICKEL UNDERPLATE ALL OVER, MATING SURFACES PLATED TO MEET PL1 PERFORMANCE REQUIREMENTS OF INDUSTRY SPECIFICATION EIA-700AAAB, SOLDER TAILS PLATED TIN.
- 3. DATUM LOCATIONS AND BASIC DIMENSIONS TO BE ESTABLISHED BY THE CUSTOMER. CONSULT AMP ENGINEERING WHEN PLACING MULTIPLE CONNECTORS ON A PC BOARD.
- 4. PACKAGED IN TAPE ON REEL PER EIA-481.
- 5. VACUUM COVER DESIGNED FOR 4mm DIA. NOZZLE. COVER TO BE REMOVED AFTER SOLDERING. VACUUM COVER OMITTED FROM SOME VIEWS FOR DIMENSIONAL CLARITY.
- 6. SHORTER SOLDER LANDS MAY BE USED PER EIA 700AAAB, HOWEVER 2.4 LENGTH ASSURES OPTIMUM SOLDER FILLET REGARDLESS OF MANUFACTURER OF CONNECTOR.
- 7. REFERRED TO AS DIM H = 8.3±0.1 IN EIA 700AAAB SPECIFICATION.
- 8. 5.5 MIN DIAMETER TARGET AREA FOR VACUUM PICK-UP.
- 9. CONTACT FINISH: 0.00381 MINIMUM MATTE TIN PER ASTM B 545 ON SOLDER AREA; 0.00127 MINIMUM GOLD PER ASTM B 488 ON MATING AREA, BOTH OVER 0.00127 MINIMUM NICKEL PER SAE-AMS-QQ-N-290 ON ENTIRE CONTACT.

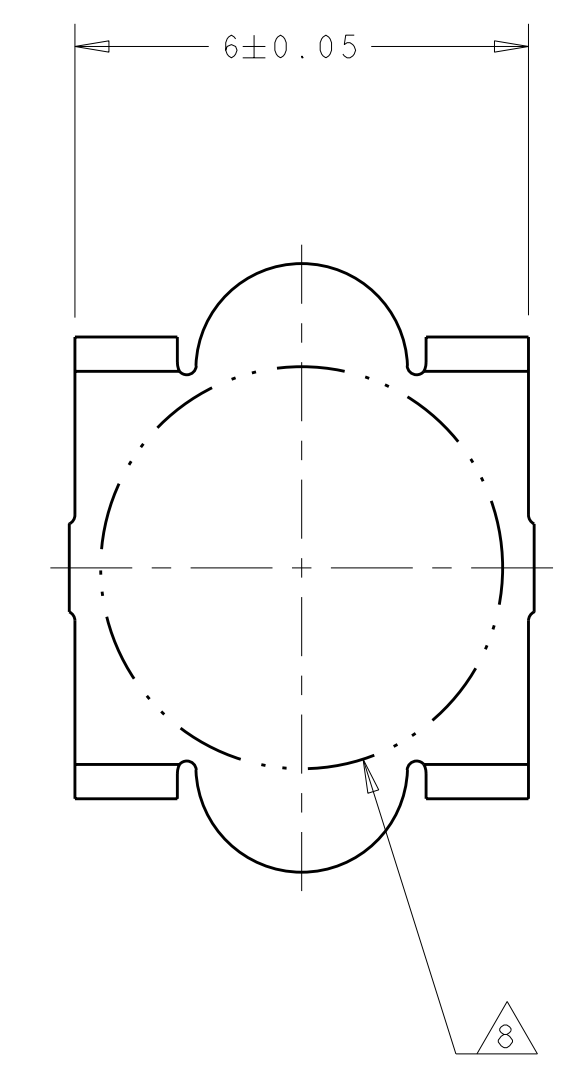
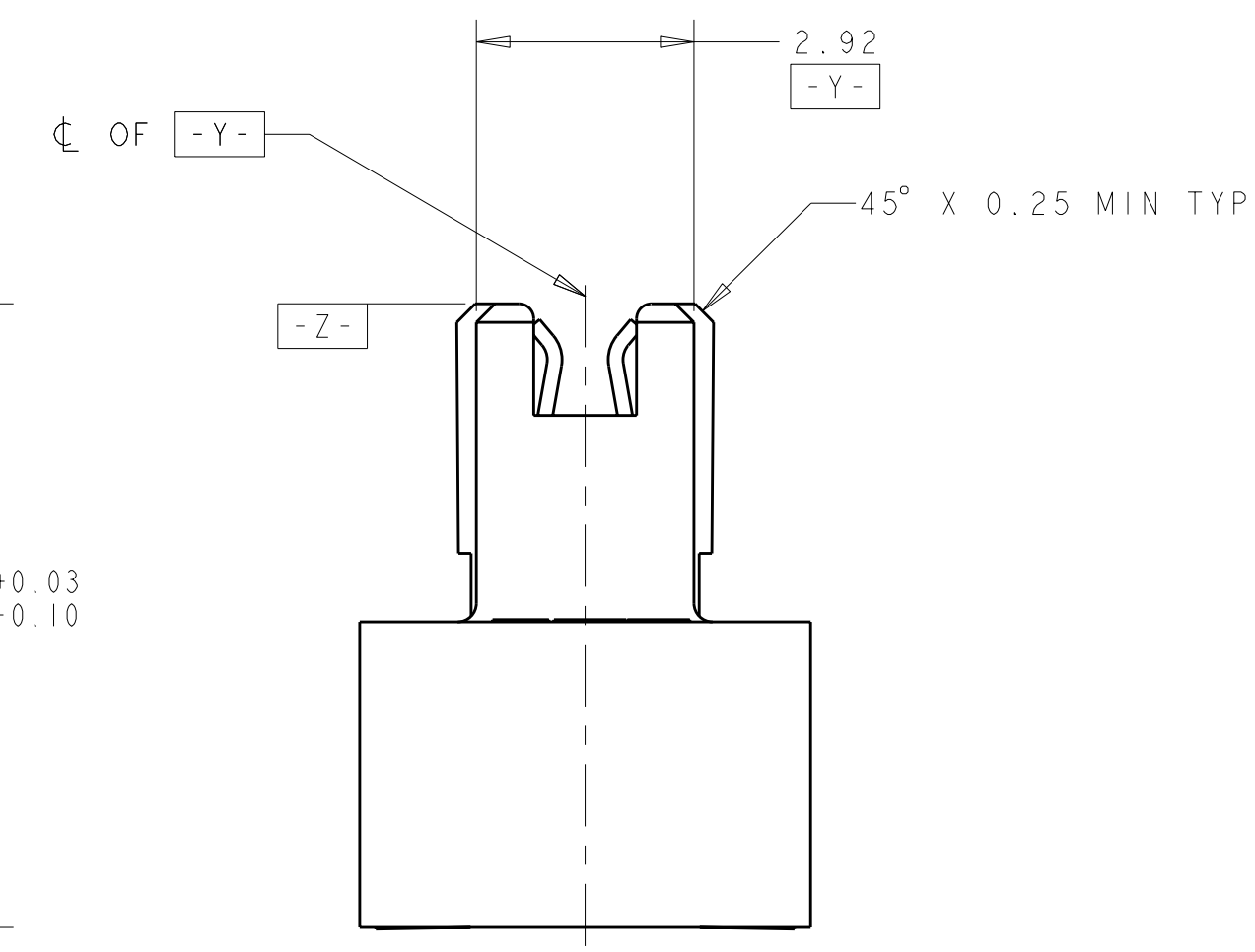
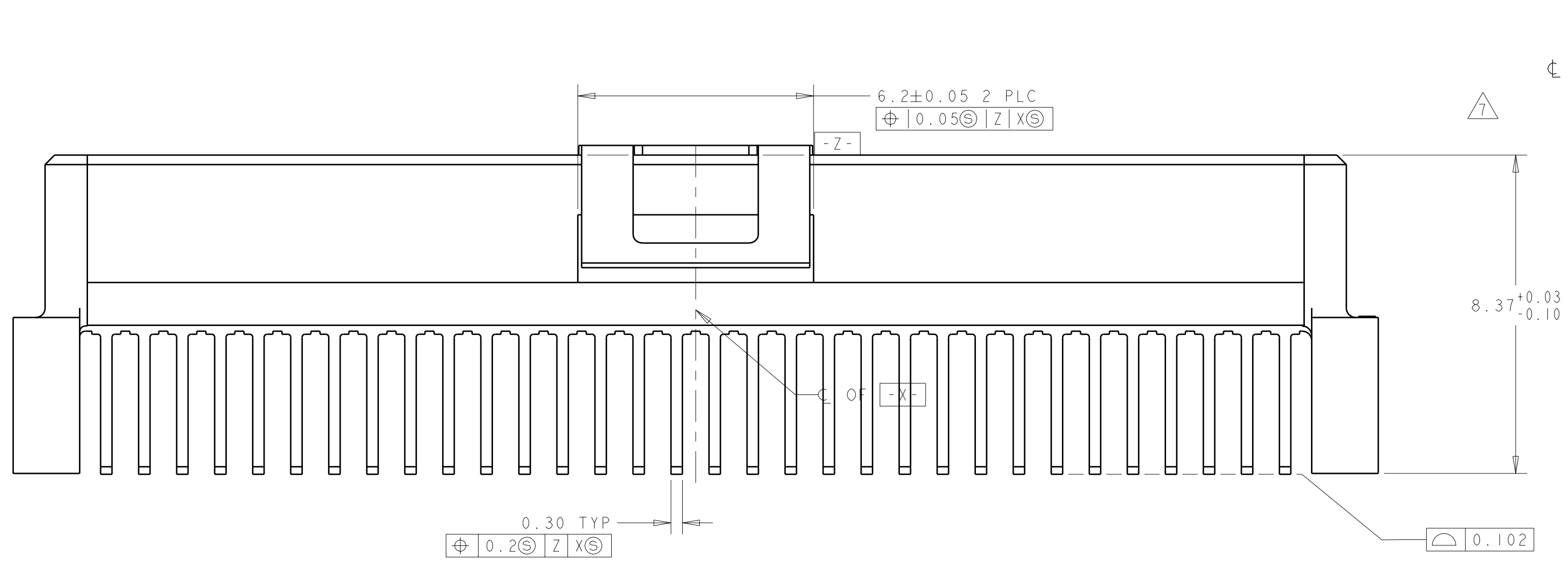

VACUUM COVER

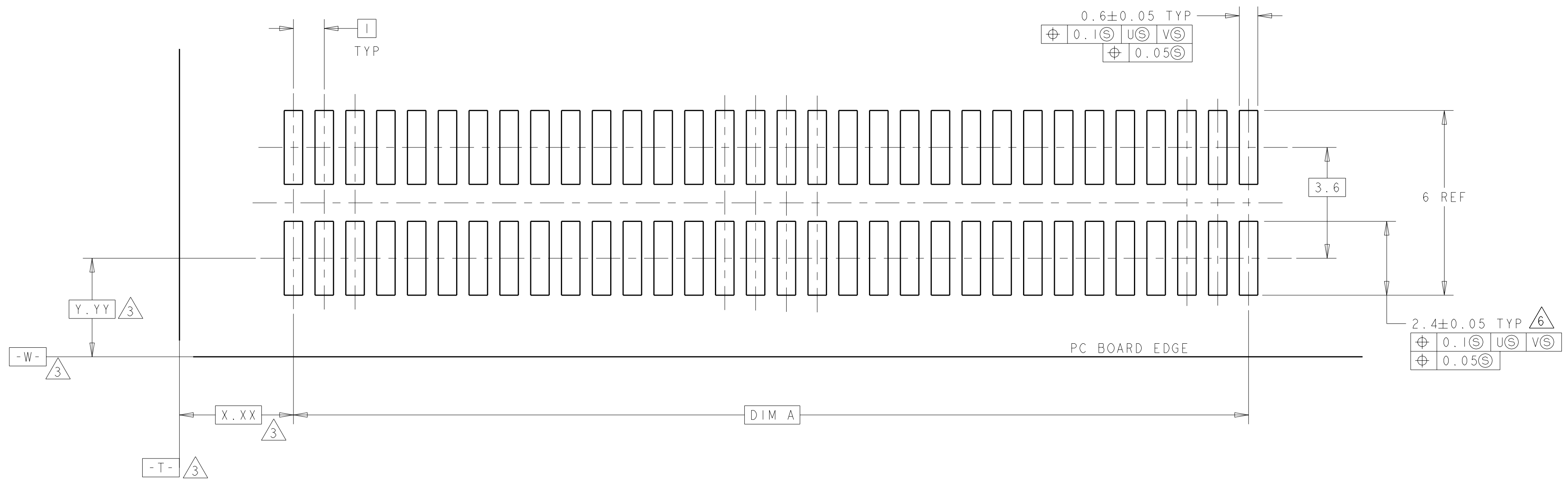

RECOMMENDED PC BOARD LAYOUT

FINISH	DIM C	DIM B	DIM A	MATING CONNECTOR	STACK HGTS	POS	PART NO
1	45.9	44.22	41	5120534-2	13	84	1-5120530-2
2	35.9	34.22	31	5120534-1	13	64	1-5120530-1
3	45.9	44.22	41	5120534-2	13	84	5120530-2
4	35.9	34.22	31	5120534-1	13	64	5120530-1

DIMENSIONS: mm TOLERANCES UNLESS OTHERWISE SPECIFIED: 9 PLC ± 7 PLC ±0.03 5 PLC ±0.003 4 PLC ± ANGLES ±0°-1'		DWN B. CARBO 30SEP04 CHK R. WERTZ 30SEP04 APVD R. WERTZ 30SEP04		<b>tyco</b> Electronics Tyco Electronics Harrisburg, PA 17105-3608	
MATERIAL: SEE TABLE		PRODUCT SPEC: 502-1079 APPLICATION SPEC: 114-25045		NAME: RCPT ASSY, W/COVER, 1.0mmFH (IEEE1386) CONNECTOR	
WEIGHT: -		CUSTOMER DRAWING		SIZE: 114-25045 CAGE CODE: A1100779 DRAWING NO: C=5120530	
SCALE: 10:1		SHEET: 1 OF 1		REV: A	