

100 W LED street lighting evaluation board using the STLUX385A digital controller

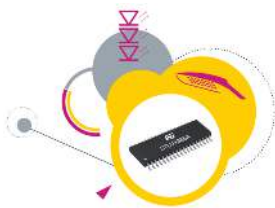

Features

- based on STLUX385A digital controller
- high efficiency (92%)
- primary side controlled
- up to 100 W (100 V at 1 A or 200 V at 0.5 A)
- single isolated output suitable for LED connection
- wide input voltage range: 90 V to 265 V AC
- adjustable LED current and dimming
- output resolution: 11-bit equivalent
- IDLE mode power consumption: < 250 mW
- real-time fault detection and protection (short-circuit or open circuit)
- remote control via:
 - DALI ed.2.0
 - 0 - 10 V
 - UART
- RoHS compliant

Description

The STEVAL-ILL066V2 evaluation board is a complete and configurable solution that efficiently controls a single, dimmable, high-brightness LED string using the STLUX385A digital controller.

The LED efficiency is high during all stages of dimming: the STEVAL-ILL066V2 can achieve a 92% efficiency at full load while maintaining a low < 250 mW power consumption in idle periods and less than 500mW during failure (open or short).

The STLUX385A device handles a primary side regulated power conversion stage as well as all the supported communication links.

The power conversion stage consists of a PFC regulator followed by a “Zero Voltage Switching” (ZVS) LC resonant stage. The high precision dimming is adjusted using a primary side regulation (PSR) control technique.

The LED brightness can be dimmed by controlling the LED current down to a very low level.

The STEVAL-ILL066V2 evaluation board provides DALI, insulated 0-10 and UART physical communication interfaces, with all communication managed by the STLUX385A device.

The flexibility of the STLUX385A device and the UART interface allow quick connection of the STEVAL-ILL066V2 to various interfaces such as Wi-Fi, power line modems, NFC, Bluetooth® and Zigbee®.

Product summary	
STEVAL-ILL066V2 evaluation board	STEVAL-ILL066V2
STLUX385A digital controller for lighting and power conversion applications	STLUX385A
STSW-ILL066V2 firmware	STSW-ILL066V2

1 Overview

Figure 1. STEVAL-ILL066V2 evaluation board



Table 1. Connector J8 pinout - AC-DC input

Name	Type	Function
ACIN	Power	Main AC/DC input
ACIN	Power	Main AC/DC input
EARTH	Power	Protective earth connection

Table 2. Connector J4 pinout - DC output

Name	Type	Function
“+”	Power	Positive load connection
“-”	Power	Negative load connection

Table 3. Connector J3 pinout - DALI interfaces

Name	Type	Function
DALI	DALI signal	DALI signal for isolated DALI interfaces - without polarization
DALI	DALI signal	DALI signal for isolated DALI interfaces - without polarization

Table 4. Connector J9 pinout - 0 - 10 V

Name	Type	Function
“+”	Positive reference	Positive reference for isolated 0 - 10 V interfaces
“-”	Negative reference	Negative reference for isolated 0 - 10 V interfaces

Table 5. Connector J48 pinout - USB - serial interfaces

Name	Type	Function
1	VBUS	Power to USB interfaces area
2	USBDN	Negative USB data signal
3	USBDP	Positive USB data signal
4	ID	Not connected
5	GND	Ground reference to USB interfaces area

Table 6. Connector J1 pinout - SWIM interfaces

Name	Type	Function
1	VCC_SWIM	power reference from board
2	SWIM	SWIM signal to/from STLUX
3	GND_SWIM	Directly connected to primary GND
4	RESn	Connected to STLUX NRST pin

2 Schematic diagrams

Figure 2. Schematic - STLUX385A - top

Figure 3. Schematic - PFC and DC/DC zone

Figure 4. Schematic - PSR-ZVS stage

Figure 5. Schematic - digital dimming stage

Figure 6. Schematic - THD optimizer

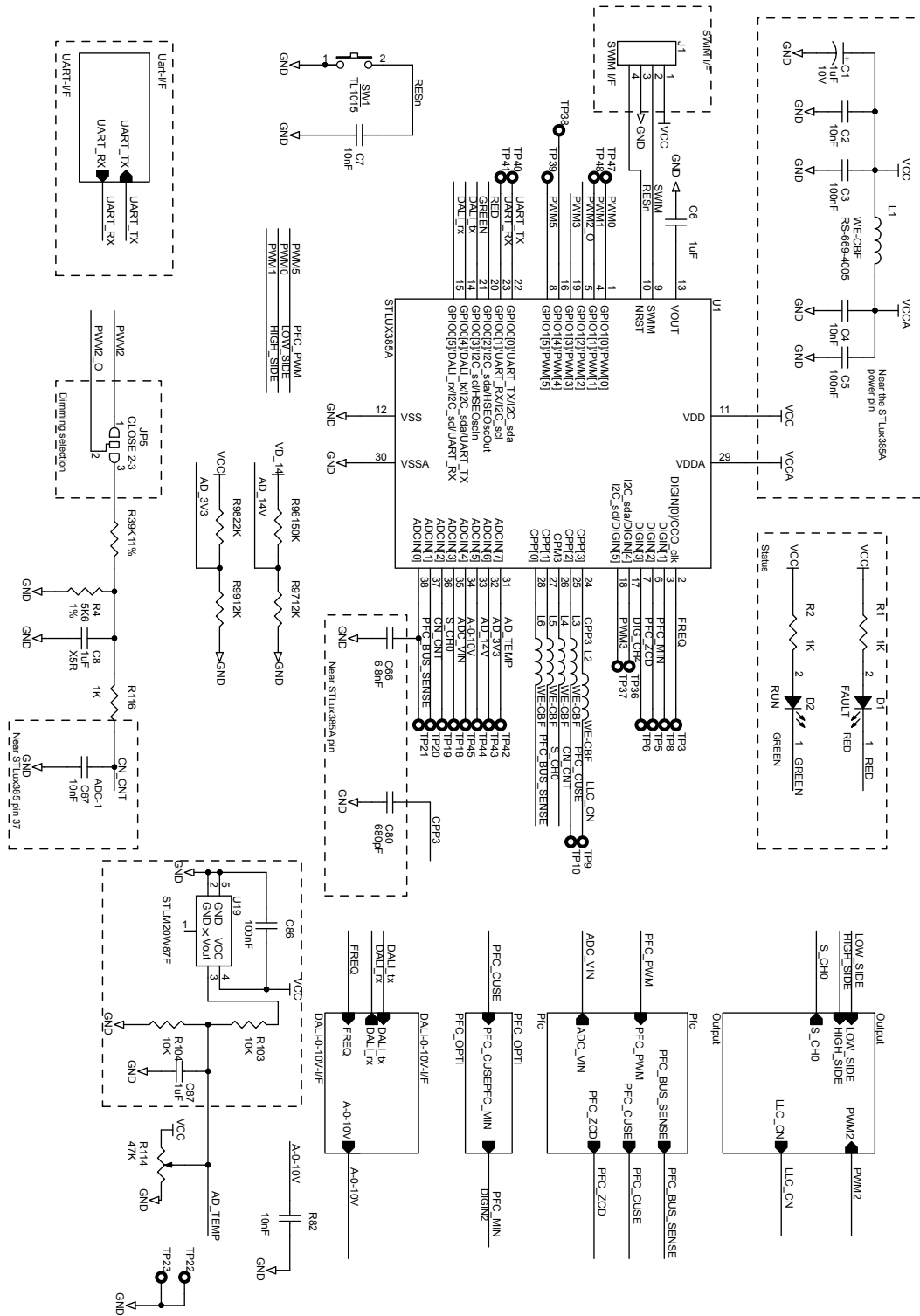
Figure 7. Schematic - DALI and 0 - 10 interfaces

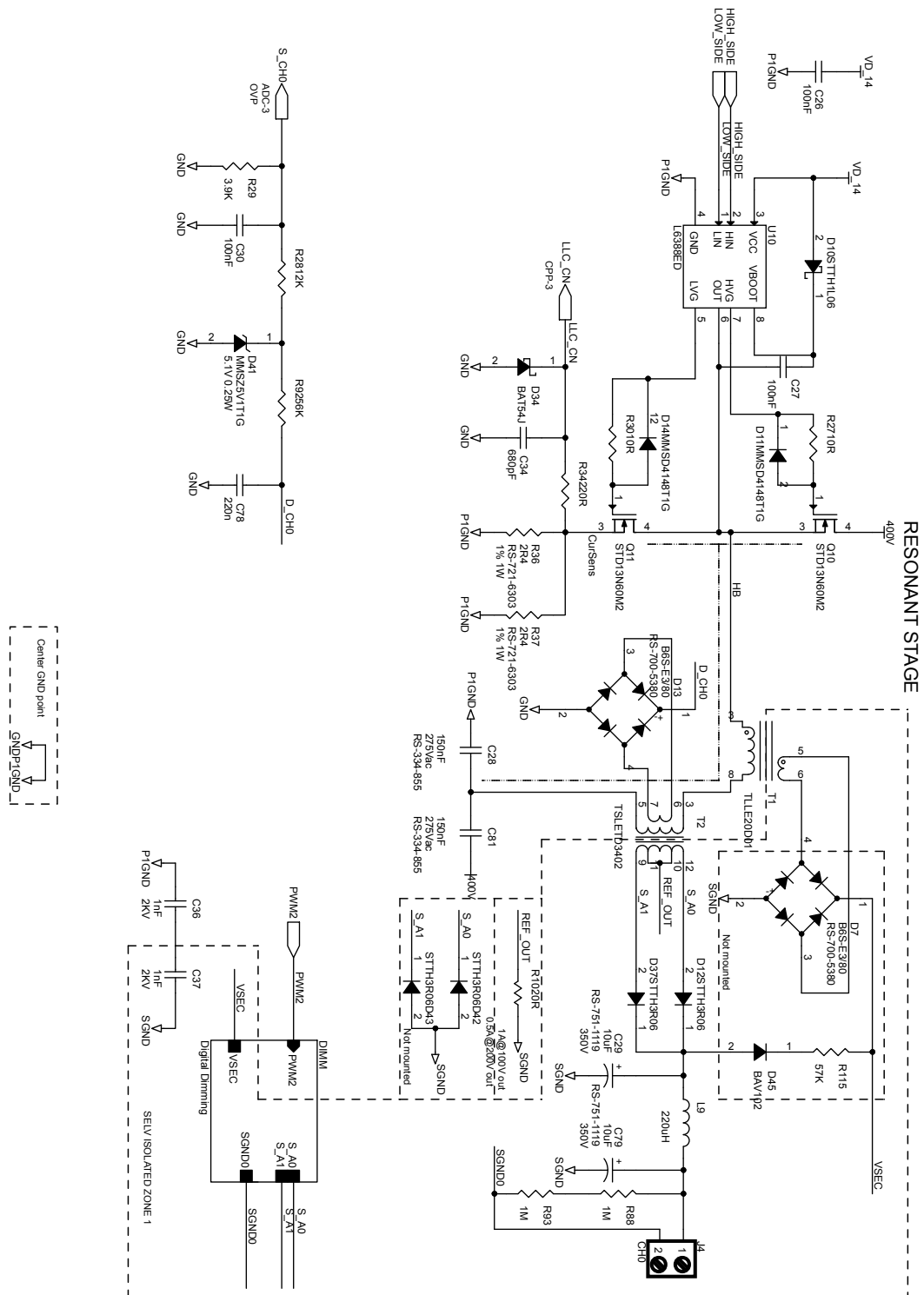
This sheet is mounted only when UART I/F is used (only R75 is always mounted)

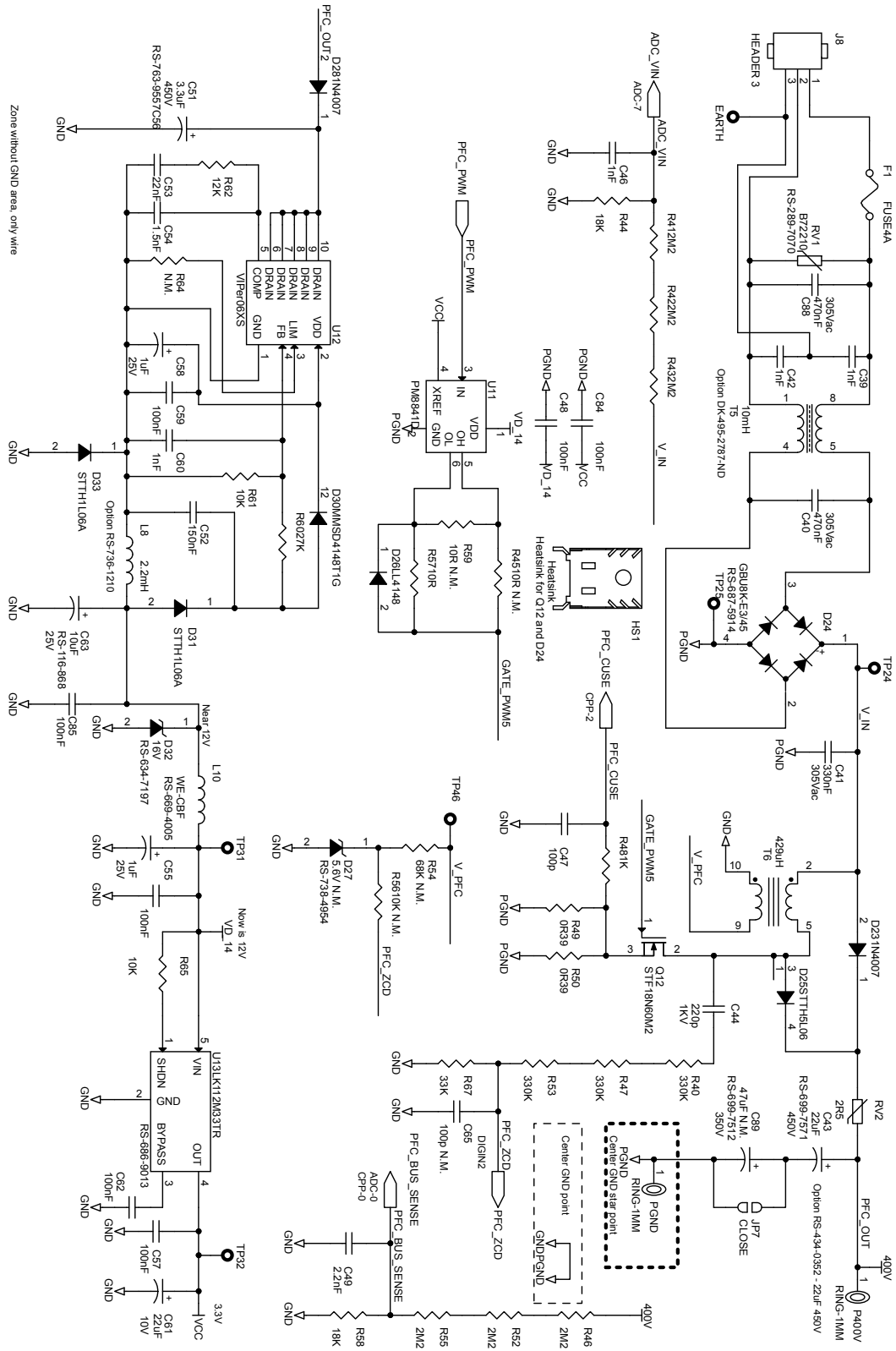
Figure 8. Schematic - serial interfaces

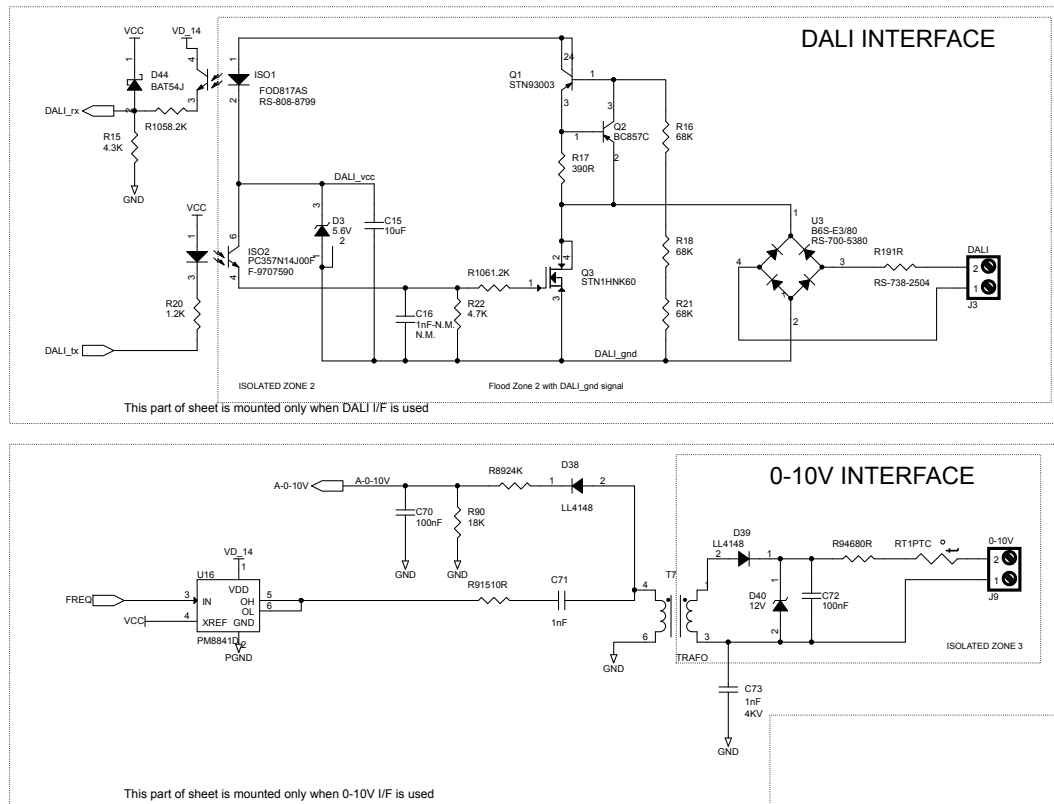
Figure 9. Schematic - USB interfaces

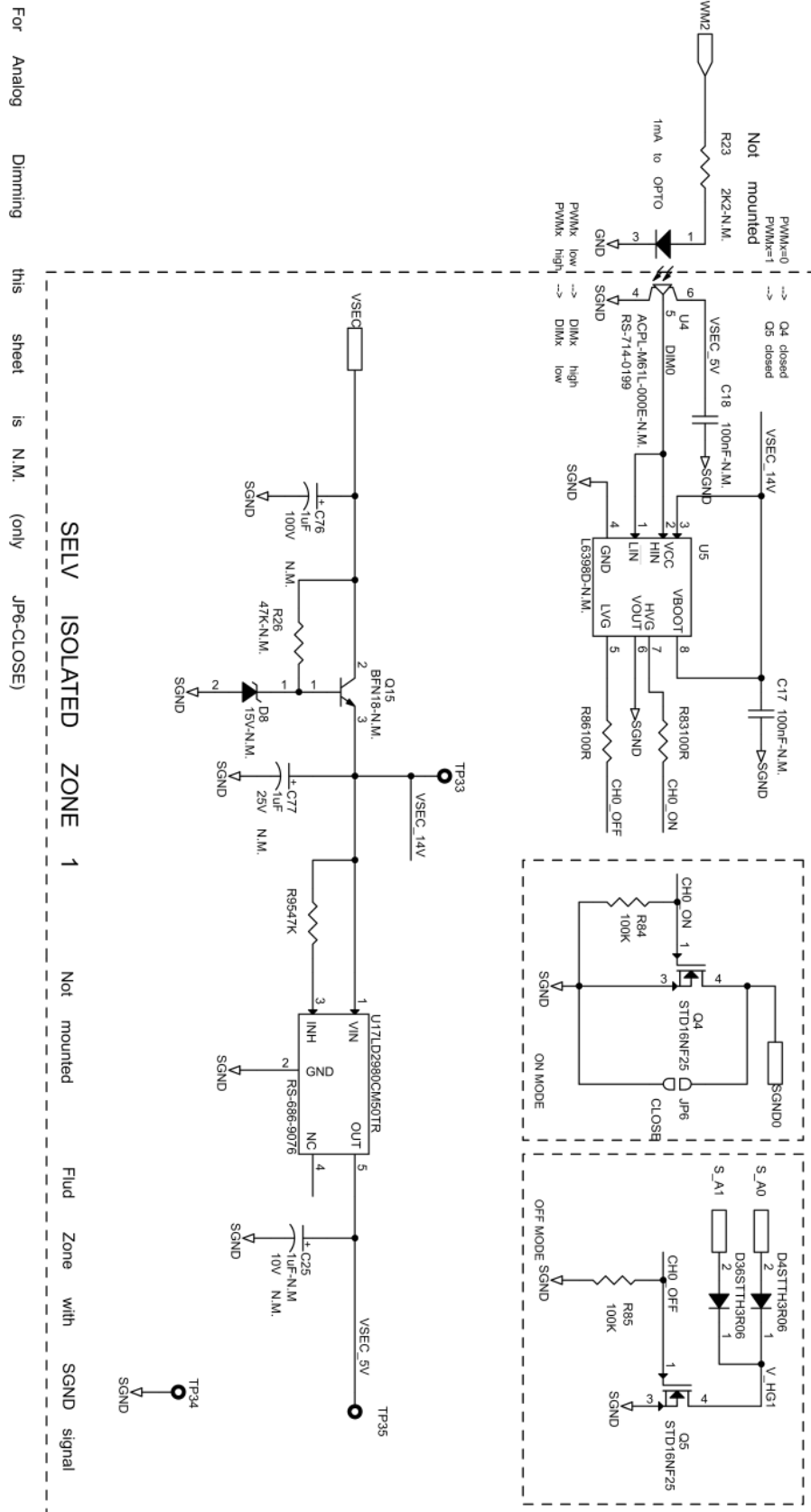
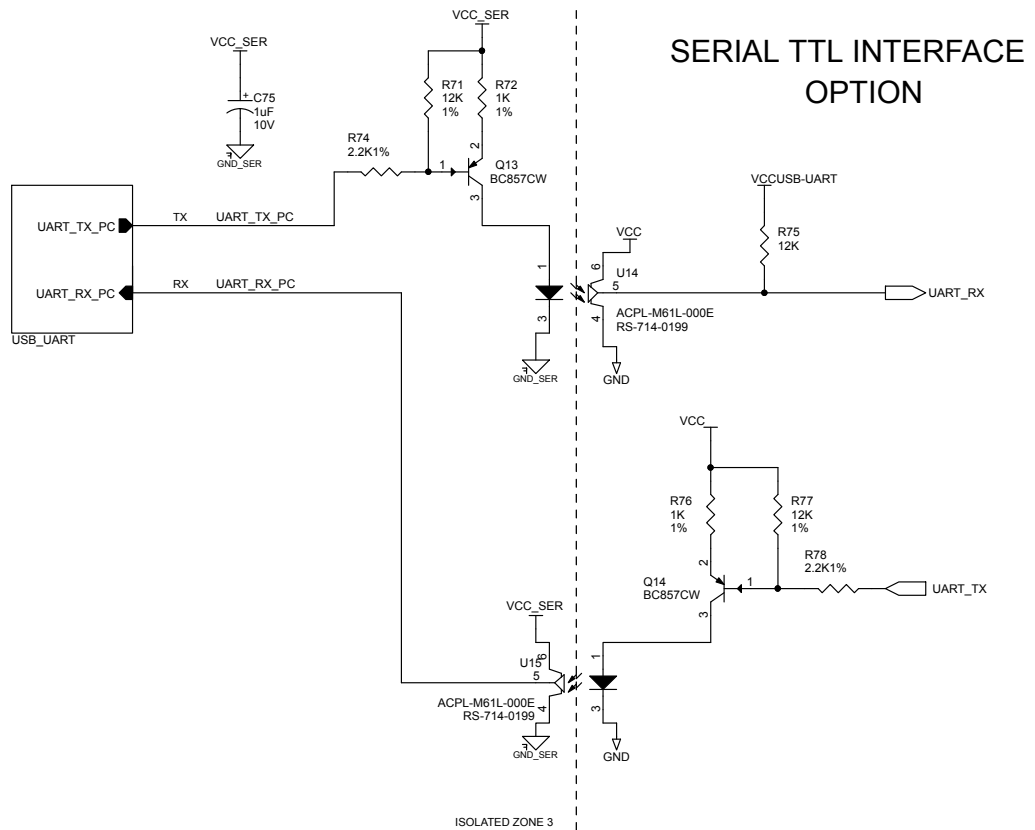
If use J48: mount R117, R111, R112, R109, R110 (default)

If use J47: remove R117, R111, R112, R109, R110

Revision history

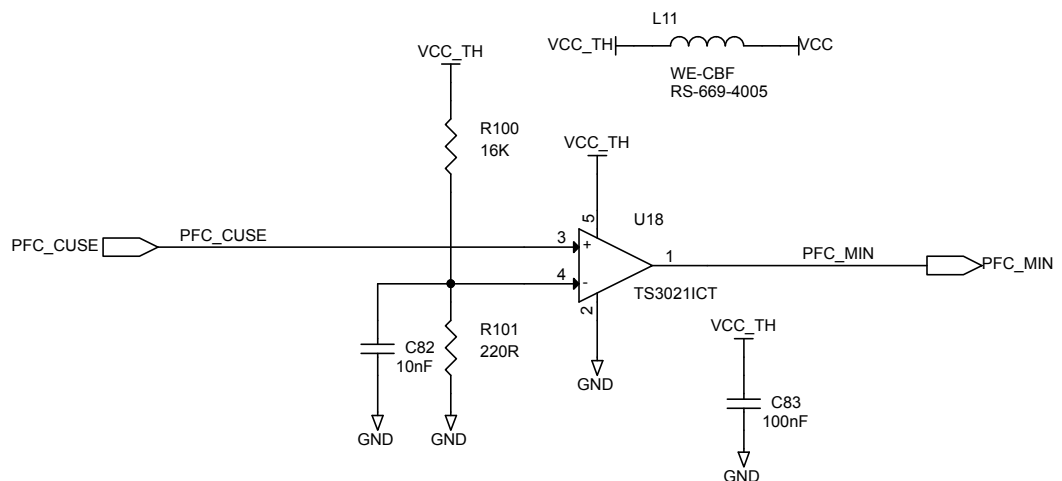
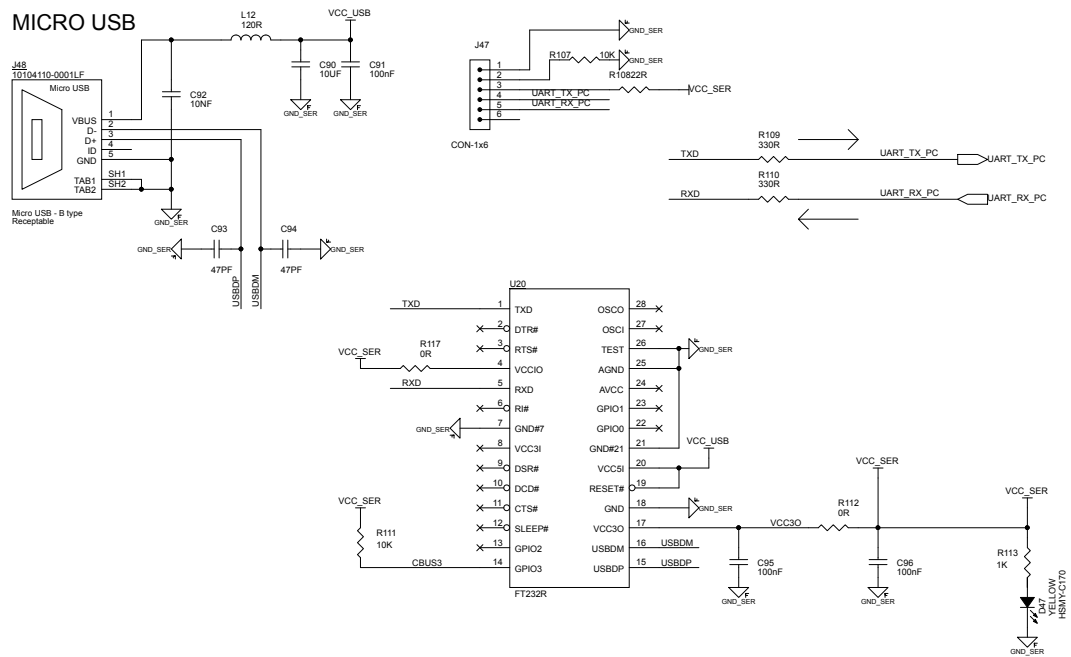
Table 7. Document revision history

Date	Version	Changes
09-Mar-2018	1	Initial release.

IMPORTANT NOTICE – PLEASE READ CAREFULLY

STMicroelectronics NV and its subsidiaries (“ST”) reserve the right to make changes, corrections, enhancements, modifications, and improvements to ST products and/or to this document at any time without notice. Purchasers should obtain the latest relevant information on ST products before placing orders. ST products are sold pursuant to ST’s terms and conditions of sale in place at the time of order acknowledgement.

Purchasers are solely responsible for the choice, selection, and use of ST products and ST assumes no liability for application assistance or the design of Purchasers’ products.

No license, express or implied, to any intellectual property right is granted by ST herein.

Resale of ST products with provisions different from the information set forth herein shall void any warranty granted by ST for such product.

ST and the ST logo are trademarks of ST. All other product or service names are the property of their respective owners.

Information in this document supersedes and replaces information previously supplied in any prior versions of this document.

© 2018 STMicroelectronics – All rights reserved