

DWG. NO. SD-54765-008

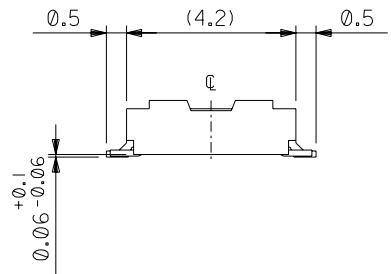
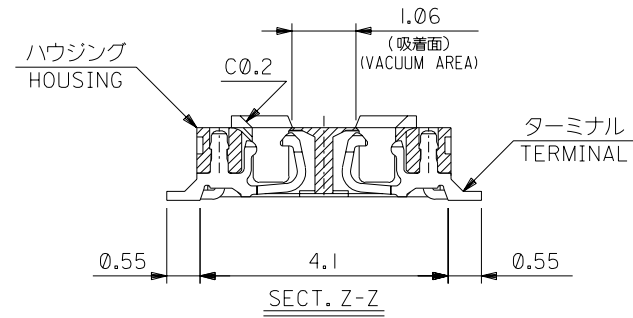
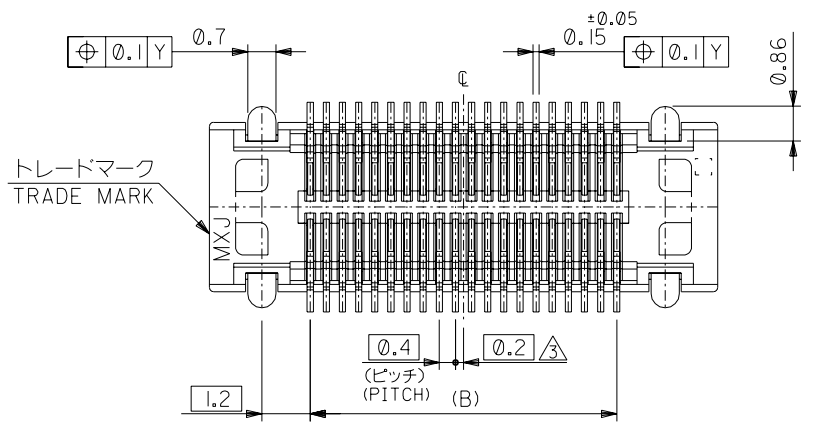
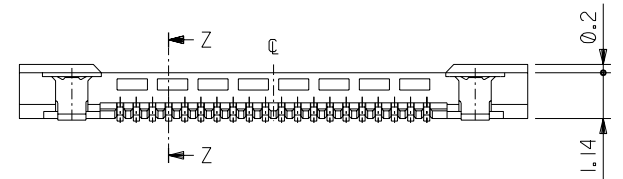
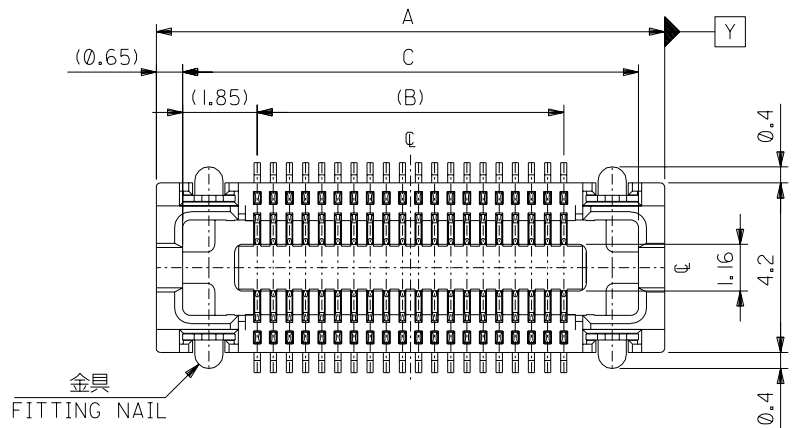

19.3	15.6	20.6	54765-0805	80
17.3	13.6	18.6	54765-0705	70
14.1	10.4	15.4	54765-0545	54
13.3	9.6	14.6	54765-0505	50
12.1	8.4	13.4	54765-0445	44
11.3	7.6	12.6	54765-0405	40
9.3	5.6	10.6	54765-0305	30
8.1	4.4	9.4	54765-0245	24
7.7	4.0	9.0	54765-0225	22
C	B	A	MATERIAL NO.	Ck+

DO NOT SCALE DRAWING

64 NO. DRWN: CH'K: APPR:	63 NO. DRWN: CH'K: APPR:	62 NO. DRWN: CH'K: APPR:	61 NO. DRWN: CH'K: APPR:	REVISED '02/07/01 60 NO. J2003-0008 DRWN: T.TSUBOI CH'K: T.ITO APPR: T.YAMAGUCHI	MATERIAL 材料 FINISH 仕上げ WIRE RANGE 適用線径範囲 INS. RANGE 被覆外径	DESCRIPTION 注記参照 SEE NOTES // // //
-----------------------------	-----------------------------	-----------------------------	-----------------------------	--	---	--

GENERAL TOLERANCES: (UNLESS SPECIFIED) 一般公差	10 UNDER 未満 ±0.2	10 OVER 以上 ±0.25	30 UNDER 未満 ±0.25	30 OVER 以上 ±0.3	ANGLE 角度 ±3°
---	---------------------	---------------------	----------------------	--------------------	-----------------

MODEL NO.	54765-***5	DIMENSIONS:	SHT	REV
SCALE	DESIGN UNITS	<input type="checkbox"/> mm <input type="checkbox"/> INCH <input checked="" type="checkbox"/> mm ONLY	<input type="checkbox"/> mm <input type="checkbox"/> INCH <input checked="" type="checkbox"/> mm ONLY	<input type="checkbox"/> mm <input type="checkbox"/> INCH <input checked="" type="checkbox"/> mm ONLY
DRAWN BY & DATE R.TAKEUCHI '00/10/16	CHECKED BY & DATE T.ITO '02/07/01	APPROVED BY & DATE T.YAMAGUCHI '02/07/01	TITLE: 0.4 B-To-B Rec Hsg Assy WITH GUIDE (Hgt=1.5)	
CAD FILENAME		MATERIAL NO.	DRAWING NO.	SHEET NO.
54765008.S01		SEE CHART	SD-54765-008	1 OF 2
THIS DRAWING CONTAINS INFORMATION THAT IS PROPRIETARY TO MOLEX INCORPORATED AND SHOULD NOT BE USED WITHOUT WRITTEN PERMISSION.				SIZE B

54765008.S01

DWG. NO.
SD-54765-008

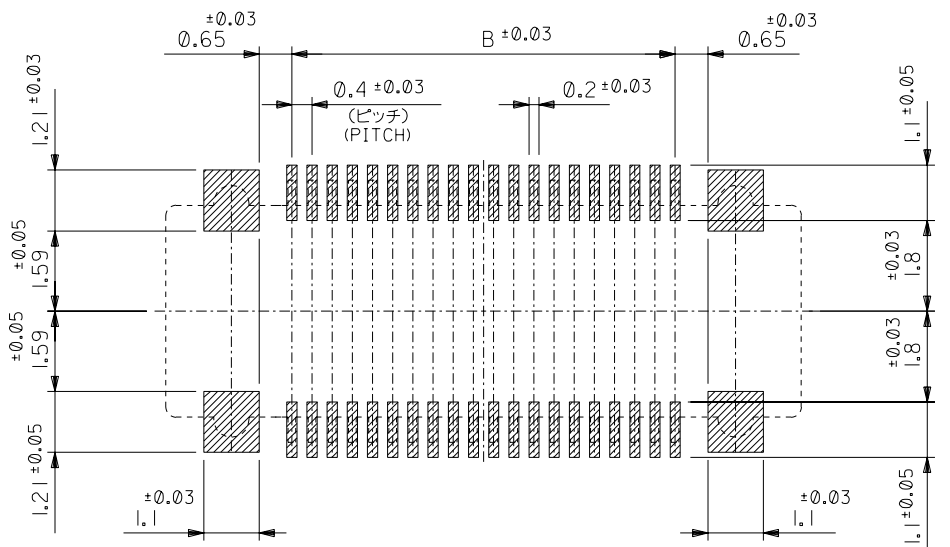

参考基板レイアウト (マウント面)
P.C.BOARD PATTERN DIMENSION. (REFERENCE)
(MOUNTING AREA)

注記 NOTES

- 使用材料 MATERIAL
ハウジング: 液晶ポリマー ガラス充填 UL94V-0 (黒)
HOUSING: LIQUID CRYSTAL POLYMER (GLASS FILLED)
UL94V-0 (COLOR: BLACK)
ターミナル: リン青銅 (t=0.15)
TERMINAL: PHOSPHOR BRONZE (t=0.15)
金具: リン青銅 (t=0.15)
FITTING NAIL: PHOSPHOR BRONZE (t=0.15)
 - メッキ仕様 PLATING
ターミナル TERMINAL
金メッキ 0.25マイクロメートル以上 (コンタクト部)
GOLD 0.25MICROMETER MINIMUM (CONTACT AREA)
金メッキ 0.4マイクロメートル以下 (テール部)
GOLD 0.4MICROMETER MAXIMUM (TAIL AREA)
下地メッキ: ニッケルメッキ 1.5マイクロメートル以上
UNDER PLATING: NICKEL 1.5MICROMETER MINIMUM
金具 FITTING NAIL
半田メッキ 3.0マイクロメートル以上
Sn-Pb 3.0MICROMETER MINIMUM
下地メッキ: 銅メッキ 1.0マイクロメートル以上
UNDER PLATING: Cu 1.0MICROMETER MINIMUM
- △ (全極数/2) = 偶数の場合に適用。
APPLY FOR (CIRCUIT/2) = EVEN
- 嵌合相手: 55604-***1, 55604-***5
MATE WITH: 55604-***1, 55604-***5
 - テール平坦度は、0.08以下
テール及び金具の平坦度は、0.1以下
TAIL COPLANARITY TO BE 0.08 MAXIMUM.
TAIL AND FITTING NAIL
COPLANARITY TO BE 0.1 MAXIMUM.

DO NOT SCALE DRAWING

64 NO. DRWN: CH'K: APPR: 63 NO. DRWN: CH'K: APPR: 62 NO. DRWN: CH'K: APPR: 61 NO. DRWN: CH'K: APPR:		REVISED '02/07/01 60 NO. J2003-0008 DRWN: T.TSUBOI CH'K: T.ITO APPR: T.YAMAGUCHI	MATERIAL 材料 注記参照 SEE NOTES	GENERAL TOLERANCES: (UNLESS SPECIFIED) 一般公差 10 UNDER 未満 ±0.2 10 OVER 以上 ±0.25 30 OVER 以上 ±0.3 ANGLE 角度 ±3°	SCALE 1/1 DESIGN UNITS <input checked="" type="checkbox"/> mm <input type="checkbox"/> INCH DRAWN BY & DATE R.TAKEUCHI '00/10/16 CHECKED BY & DATE T.ITO '02/07/01 APPROVED BY & DATE T.YAMAGUCHI '02/07/01 CAD FILENAME 54765008.S02	MODEL NO. 54765-***5 DIMENSIONS: <input type="checkbox"/> mm <input type="checkbox"/> INCH <input checked="" type="checkbox"/> mm <input type="checkbox"/> INCH ONLY SHT 2 OF 2 REV TITLE: 0.4 B-To-B Rec Hsg Assy WITH GUIDE (Hgt=1.5) MOLEX MOLEX INCORPORATED	MATERIAL NO. SEE CHART DRAWING NO. SD-54765-008 SHEET NO. 2 OF 2 SIZE B
WIRE RANGE 適用線径範囲 // INS. RANGE 被覆外径 //			7888 DRAWING CONTAINS INFORMATION THAT IS PROPRIETARY TO MOLEX INCORPORATED AND SHOULD NOT BE USED WITHOUT WRITTEN PERMISSION.				

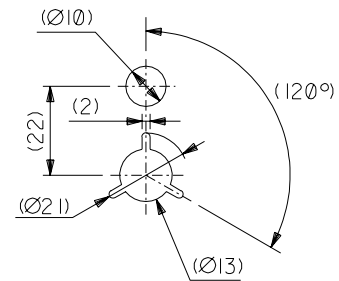
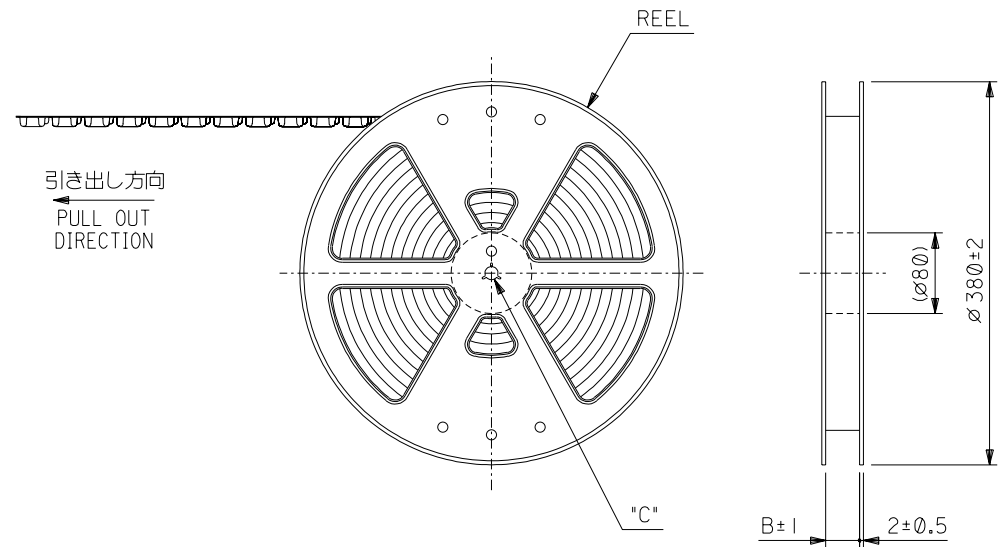

DETAIL "C"

注記 NOTES

- 製品詳細寸法については図面 SD-54765-008 を参照下さい。
RE DETAILED DIMENSION, SEE SD-54765-008
- 梱包数量：2500個/リール
NUMBER OF CONNECTORS : 2500PCS/REEL
- リードテープ長さ LEAD TAPE LENGTH

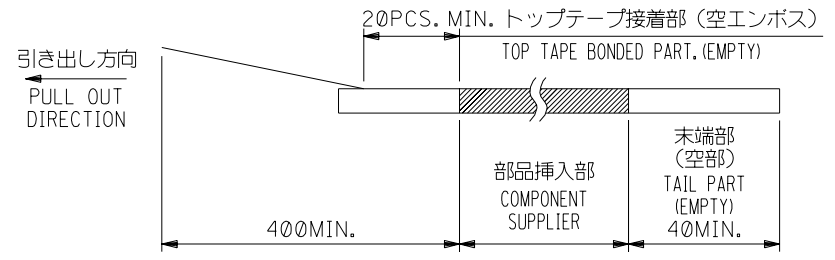

- トップテープの剥離強度：0.1N ~ 0.7N (10.2gf ~ 71.4gf)
(剥離方向は下図参照)
尚、本規格値は出荷時に適用。(但し、輸送時に剥離が発生しないこと。)
PEELING OFF FORCE OF TOP TAPE : 0.1N ~ 0.7N (10.2gf ~ 71.4gf)
(PEELING DIRECTION AS SHOWN IN FOLLOWING FIG.)
THIS REQUIREMENT SHOULD BE APPLIED AT SHIPMENT.
PEEL OFF SHOULD NOT BE ALLOWED, DURING TRANSPORTATION.

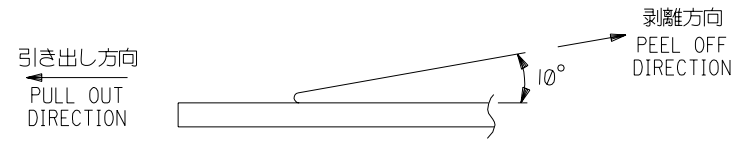

- 材料 MATERIAL
キャリアテープ (CARRIER TAPE) : ポリプロピレン (POLYPROPYLENE)
トップテープ (TOPTAPE) : PET, PE, PEF
リール (REEL) : ポリスチレン (PS) <リサイクル材を含む>
POLYSTYRENE (PS) <RECYCLE MATERIAL CONTAINED>

④64NO. DRWN: CH'K: APPR:		④63NO. DRWN: CH'K: APPR:		④62NO. DRWN: CH'K: APPR:		REVISED '02/07/01 ④61NO. J2003-0008 DRWN: T.TSUBOI CH'K: T.IITO APPR: T.YAMAGUCHI		REVISED '02/02/18 ④60NO. J2002-2030 DRWN: R.TAKEUCHI CH'K: T.IITO APPR: T.YAMAGUCHI		MATERIAL 材料 注記参照 SEE NOTES		GENERAL TOLERANCES: (UNLESS SPECIFIED) 一般公差		SCALE 1/1		DESIGN UNITS <input checked="" type="checkbox"/> mm <input type="checkbox"/> INCH		MODEL NO. 54765-***6		DIMENSIONS: <input type="checkbox"/> mm <input type="checkbox"/> INCH <input checked="" type="checkbox"/> mm ONLY		SHT 1 OF 3 REV	
WIRE RANGE 適用線径範囲		FINISH 仕上げ		WIRE RANGE 適用線径範囲		WIRE RANGE 適用線径範囲		WIRE RANGE 適用線径範囲		WIRE RANGE 適用線径範囲		10 UNDER 未満 ±0.2		DRAWN BY & DATE R.TAKEUCHI '00/10/16		TITLE: 0.4 B-To-B Rec Assy W/Gde (Hgt=1.5) Embstp Pkg		MOLEX MOLEX INCORPORATED		SHEET NO. 1 OF 3			
INS. RANGE 被覆外径		INS. RANGE 被覆外径		INS. RANGE 被覆外径		INS. RANGE 被覆外径		INS. RANGE 被覆外径		INS. RANGE 被覆外径		10 OVER 30 UNDER 未満 ±0.25		CHECKED BY & DATE T.IITO '02/07/01		MATERIAL NO. SEE CHART		DRAWING NO. SD-54765-009		SIZE B			
30 OVER 以上 ±0.3		30 OVER 以上 ±0.3		30 OVER 以上 ±0.3		30 OVER 以上 ±0.3		30 OVER 以上 ±0.3		30 OVER 以上 ±0.3		30 OVER 以上 ±0.3		APPROVED BY & DATE T.YAMAGUCHI'02/07/01		CAD FILENAME 54765009.S01		EN-02J(097) MXJ-54					
ANGLE 角度 ±3°		ANGLE 角度 ±3°		ANGLE 角度 ±3°		ANGLE 角度 ±3°		ANGLE 角度 ±3°		ANGLE 角度 ±3°		ANGLE 角度 ±3°		20PCS. MIN. トップテープ接着部 (空エンボス) TOP TAPE BONDED PART. (EMPTY)		部品挿入部 COMPONENT SUPPLIER		末端部 (空部) TAIL PART (EMPTY) 40MIN.					

64 NO. DRWN: CH'K: APPR:	63 NO. DRWN: CH'K: APPR:	62 NO. DRWN: CH'K: APPR:	REVISED '02/07/01 61 NO. J2003-0008 DRWN: T.TSUBOI CH'K: T.IITO APPR: T.YAMAGUCHI	REVISED '02/02/18 60 NO. J2002-2030 DRWN: R.TAKEUCHI CH'K: T.IITO APPR: T.YAMAGUCHI	MATERIAL 材料 注記参照 SEE NOTES
			F	E	
					FINISH 仕上げ //
					WIRE RANGE 適用層線範囲 //
					INS. RANGE 被覆外径 //

24mm幅キャリアテープ
24mm WIDTH CARRIER TAPE

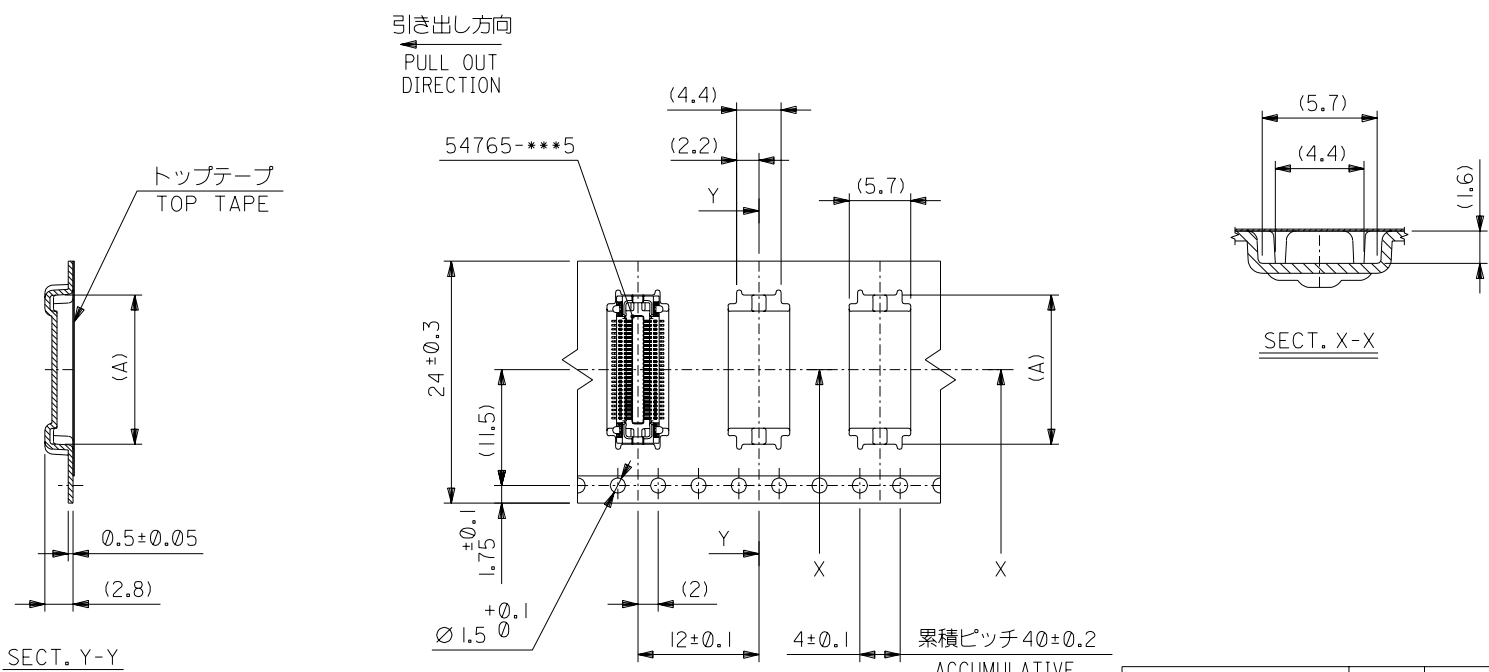

24	25.5	15.6	54765-0546	54
		14.8	54765-0506	50
		13.6	54765-0446	44
		12.8	54765-0406	40
		10.8	54765-0306	30
		9.6	54765-0246	24
		9.2	54765-0226	22
キャリアテープ幅 CARRIER TAPE WIDTH		(A)	MATERIAL NO.	極数 Ck+

MODEL NO.	54765-***6	DIMENSIONS:		SHT	REV
DESIGN UNITS	<input checked="" type="checkbox"/> mm <input type="checkbox"/> INCH	<input type="checkbox"/> mm <input type="checkbox"/> INCH	<input checked="" type="checkbox"/> mm ONLY		
SCALE	///	PROJECTION			
DRAWN BY & DATE	R.TAKEUCHI '00/10/16	TITLE:			
CHECKED BY & DATE	T.IITO '02/07/01	0.4 B-To-B Rec Assy W/Gde (Hgt=1.5) Embstp Pkg			
APPROVED BY & DATE	T.YAMAGUCHI '02/07/01	MOLEX MOLEX INCORPORATED			
CAD FILENAME	54765009.S02	MATERIAL NO.	DRAWING NO.	SHEET NO.	
		SEE CHART	SD-54765-009	2 OF 3	
DRAWING CONTAINS INFORMATION THAT IS PROPRIETARY TO MOLEX INCORPORATED AND SHOULD NOT BE USED WITHOUT WRITTEN PERMISSION.					SIZE B

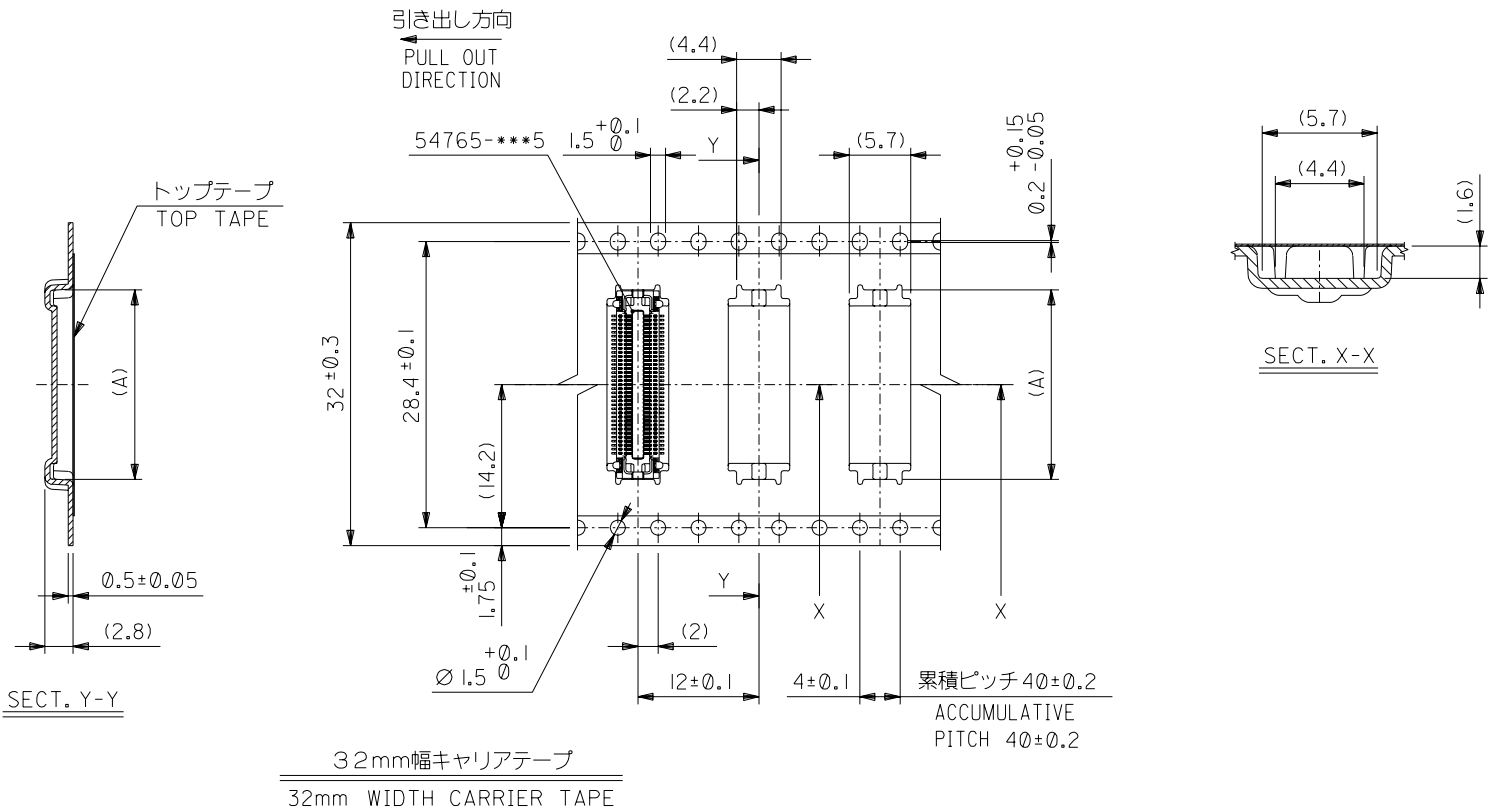

32mm幅キャリアテープ
32mm WIDTH CARRIER TAPE

32	33.5	20.8	54765-0806	80
		18.8	54765-0706	70
キャリアテープ幅 CARRIER TAPE WIDTH		B	(A)	MATERIAL NO. 種数 Ck+

MODEL NO.	54765-***6	DIMENSIONS:	SHT	REV
DESIGN UNITS	<input checked="" type="checkbox"/> mm <input type="checkbox"/> INCH	<input type="checkbox"/> mm <input type="checkbox"/> INCH	<input type="checkbox"/> mm <input type="checkbox"/> INCH	<input checked="" type="checkbox"/> mm <input type="checkbox"/> INCH
PROJECTION	<input checked="" type="checkbox"/> FIRST ANGLE	UNLESS OTHERWISE SPECIFIED		

DRAWN BY & DATE	TITLE:		
T.TSUBOI '01/07/23	0.4 B-To-B Rec Assy W/Gde (Hgt=1.5) Embstp Pkg		
CHECKED BY & DATE	MATERIAL NO.		
T.ITO '02/07/01	DRAWING NO.		
APPROVED BY & DATE	SEE CHART		SHEET NO.
T.YAMAGUCHI '02/07/01	SD-54765-009		3 OF 3
CAD FILENAME	SIZE		
54765009.S03	B		

DO NOT SCALE DRAWING	REVISED '02/07/01	MATERIAL 材料	注記参照 SEE NOTES	GENERAL TOLERANCES: (UNLESS SPECIFIED) 一般公差	SCALE	DESIGN UNITS	PROJECTION
	REVISED '02/07/01				///		
REVISED '02/02/18	FINISH 仕上げ	DESCRIPTION	WIRE RANGE 適用層線範囲	ANGLE 角度	10 UNDER 未満	±0.2	DRAWN BY & DATE
REVISED '02/01/08					10 OVER 30 UNDER 未満	±0.25	T.TSUBOI '01/07/23
REVISED '02/01/08	30 OVER 以上	///	///	3°	±0.3	APPROVED BY & DATE	T.YAMAGUCHI '02/07/01
REVISED '01/07/23	INS. RANGE 被覆外径	///	///	///	///	CAD FILENAME	54765009.S03

DO NOT SCALE DRAWING