

Vulcanised rubber coating

- 1
- 2
- 3
- 4
- 5
- 6
- 7
- 8
- 9
- 10
- 11
- 12
- 13
- 14
- 15
- 16
- 17
- 18

COVERING

Grey anti-trace rubber.

WHEEL CENTRE BODY

Polypropylene-based (PP) technopolymer.

ROLLING ACTION

Hub with pass-through hole.

TURNING PLATE BRACKET

Electrolytically zinc-plated steel sheet bracket.

The presence of a double ball race and direct contact between the plate and the ball race ring with built-in pin ensure excellent manoeuvrability.

FRONT-ACTUATED BRAKE

Total brake that locks the wheel and bracket rotation. The optimised dimensions and the retractible pedal ensure minimal space occupied and maximum actuation ease.

STANDARD EXECUTIONS

- **SBL-G**: turning plate bracket, without brake.
- **SBF-G**: turning plate bracket, with brake.
- **CBL-G**: turning plate bracket and threaded centre pin, without brake.
- **CBF-G**: turning plate bracket and threaded centre pin, with brake.

ENVIRONMENTAL CONDITIONS

The twin castors RE.C7-G are suitable for use in humid environments and in the presence of medium-aggressive chemical environments; use in environments with the presence of organic, chlorinated solvents, hydrocarbons and mineral oils is not recommended.



RE.C7-SBL-G

RE.C7-SBF-G

RE.C7-CBL-G

RE.C7-CBF-G

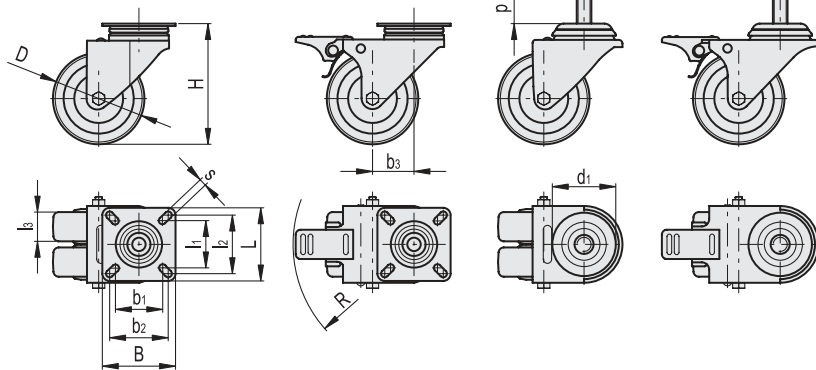

Conversion Table	
1 mm = 0.039 inch	
D	
mm	inch
50	1.97
75	2.95

METRIC

Code	Description	D	d	p	d1	b1	l1	b2	l2	l3	H	B	L	s	b3	R	Dynamic carrying capacity# [N]	ΔΔ
452002	RE.C7-050-SBL-G	50	-	-	-	38.5	38.5	48	48	18	70	60	60	6	30	-	600	350
452010	RE.C7-075-SBL-G	75	-	-	-	38.5	38.5	48	48	24	100	60	60	6	33	-	800	640
452052	RE.C7-050-SBF-G	50	-	-	-	38.5	38.5	48	48	18	70	60	60	6	30	82	600	400
452050	RE.C7-075-SBF-G	75	-	-	-	38.5	38.5	48	48	24	100	60	60	6	33	95	800	720
452152	RE.C7-050-CBL-G	50	M10	15	42	-	-	-	-	18	70	-	-	-	30	-	600	300
452160	RE.C7-075-CBL-G	75	M12	25	52	-	-	-	-	24	100	-	-	-	33	-	800	500
452202	RE.C7-050-CBF-G	50	M10	15	42	-	-	-	-	18	70	-	-	-	30	82	600	370
452210	RE.C7-075-CBF-G	75	M12	25	52	-	-	-	-	24	100	-	-	-	33	95	800	680