

DRV8305-Q1 Evaluation Module

This document is provided with the DRV8305-Q1 customer evaluation module (EVM) as a supplement to the DRV8305-Q1 ([SLVSD12](#)) data sheet. It details the hardware implementation of the EVM and how to use the DRV8305-Q1EVM with TI's MotorWare™ software repository.

Contents

1	DRV8305-Q1EVM	2
	1.1 Board Overview	2
	1.2 Jumper Settings and Test Points	3
2	Demo Application	4
	2.1 Hardware Setup	4
	2.2 MotorWare (InstaSPIN-FOC) Setup	5
	2.3 InstaSPIN Universal GUI	9
3	DRV8305-Q1EVM	13
	3.1 DRV8305-Q1EVM Schematics	13
	3.2 DRV8305-Q1EVM Bill of Materials	17

List of Figures

1	Board Key Components.....	2
2	Block Diagram.....	2
3	Board Jumpers and Test Points	3
4	Board Jumpers and Test Points	5
5	MotorWare Software Home Page	5
6	DRV8305-Q1EVM MotorWare Additions	6
7	DRV8305-Q1EVM Hal Board Files	6
8	Copied DRV8305-Q1EVM Hal Board Files.....	7
9	DRV8305-Q1EVM Solutions Board Files	7
10	Copied DRV8305-Q1EVM Solutions Board Files	8
11	CCS Import	9
12	Binary (.out) File Location	10
13	Place Binary (.out) File With GUI	10
14	Rename Binary (.out) File	10
15	Launch GUI	11
16	Enable Motor Identification.....	11
17	Enable Motor.....	11
18	DRV8305 SPI Registers.....	12
19	DRV8305-Q1EVM Emulator Schematic.....	13
20	DRV8305-Q1EVM MCU DRV Schematic	14
21	DRV8305-Q1EVM Power Schematic	15
22	DRV8305-Q1EVM Bridges Schematic	16

MotorWare, InstaSPIN-FOC, Code Composer Studio are trademarks of Texas Instruments.
All other trademarks are the property of their respective owners.

1 DRV8305-Q1EVM

1.1 Board Overview

The DRV8305-Q1EVM is a fully functional, 3-phase brushless DC (BLDC) motor drive and control evaluation platform designed for 12-V systems. It is designed to highlight the DRV8305-Q1, a 3-phase BLDC motor gate driver for automotive applications. It supports a 4- to 45-V operating voltage range and can deliver up to 25 A to the motor.

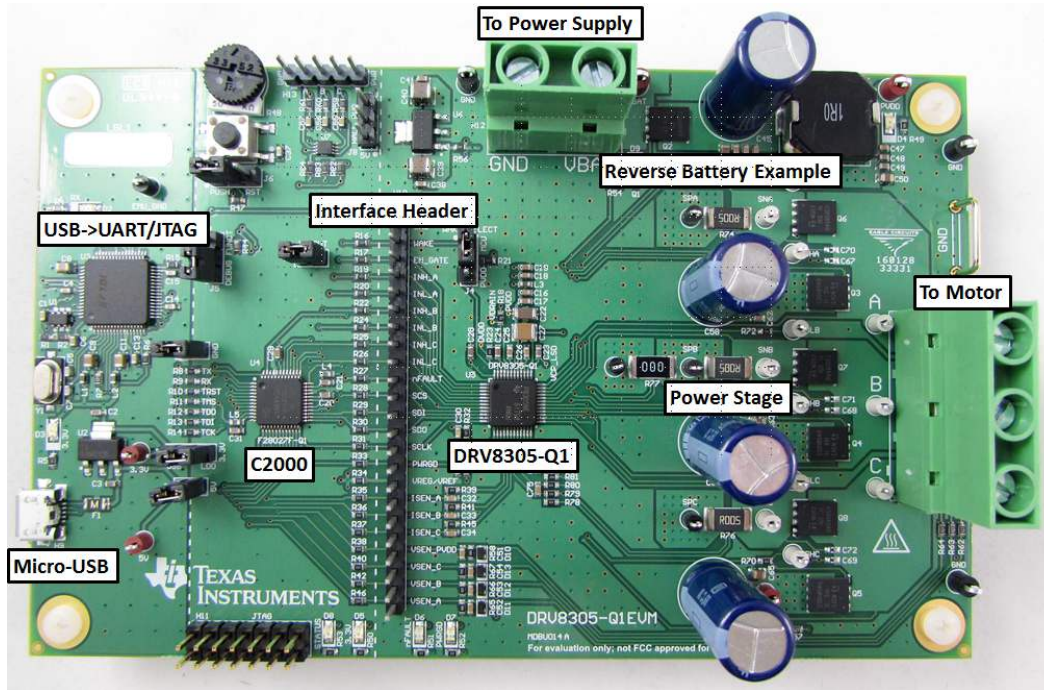

Figure 1. Board Key Components



WARNING
 Hot surfaces include the power MOSFETs (Q3-Q8), power sense resistors (R74-77), and areas around them.

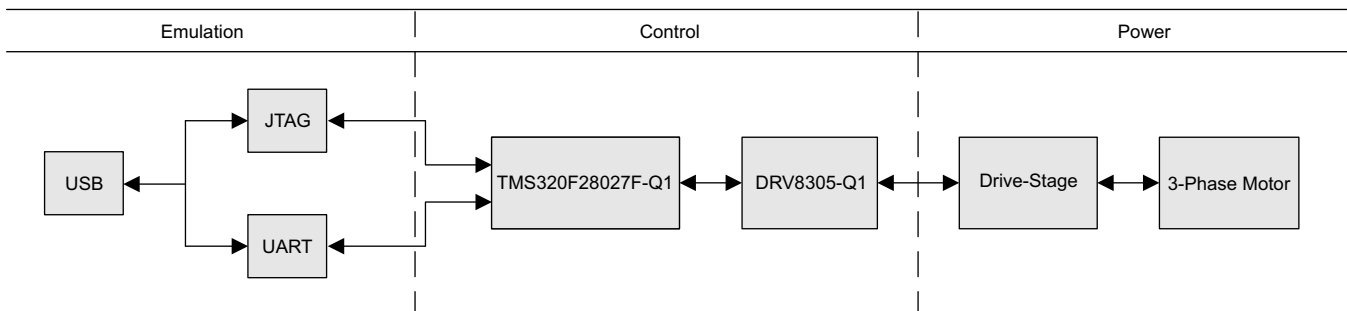

Figure 2. Block Diagram

1.2 Jumper Settings and Test Points

The DRV8305-Q1EVM has a variety of jumpers and test points to help interface with the EVM and modify its functionality.

The following numbered list correspond with the labels in [Figure 3](#):

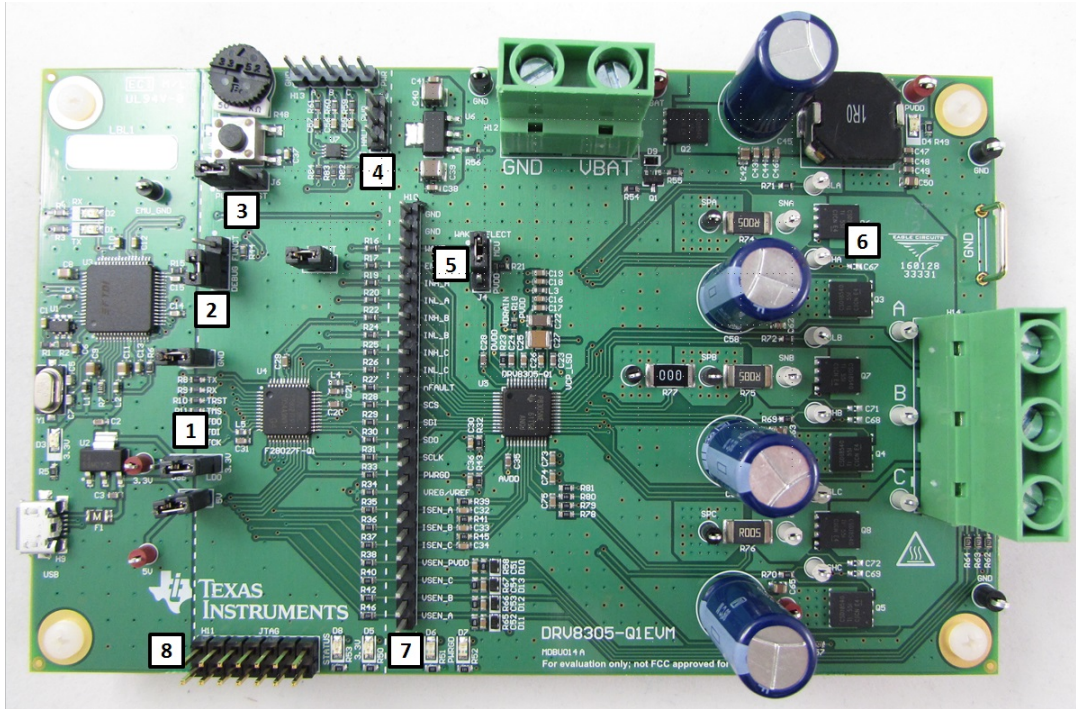

Figure 3. Board Jumpers and Test Points

1. Emulator interface (**R8–R14**, **J1–J3**) and 3.3 V select (**J3**)
 - The **R8–R14** 0-Ω resistors and **J1–J3** jumpers allow the XDS100v2 emulator circuitry to be completely disconnected from the rest of the evaluation module.
 - Use the **J3** jumper to select the source of the **3.3-V** power supply to the evaluation module. By default, this is selected for the **LDO** option, which derives power from the main power supply. Set to the **USB** option to allow for firmware debugging without the main power supply.
2. C2000 Boot Select (**J5**)

Use the **J5** jumper to select the boot option for the C2000 microcontroller. By default, this is set for **DEBUG** mode.

3. Push Button Option (**J6**)

Use the **J6 jumper** to select the functionality of the onboard **push button (S1)**. By default this is set for the **RST** mode which ties the push button to the C2000 reset pin. This may be set to the **PUSH** mode which ties the push button to a GPIO pin of the C2000 for use as an interface to the firmware application.

4. Hall Sensor Power Supply Select (**J8**)

Use the **J8 jumper** to select the power supply option for the Hall sensor header. By default, this is set for **3.3 V**, with the other option being **5 V**. The Hall sensor header is provided to develop a sensed BLDC application. The InstaSPIN-FOC™ application provided in MotorWare is a sensorless BLDC application, which does not require Hall sensor feedback.

5. WAKE Source Select (**J4**)

Use the **J4 jumper** to select the input to the WAKE pin of the DRV8305-Q1. The WAKE pin is used to bring the device out of its low-power sleep mode. The jumper is selected, by default, to drive the WAKE pin from the main power supply (**PVDD**). The other option is to drive the WAKE pin from a C2000 GPIO (**MCU**).

6. Main Interface Header (**H10**)

Use the **H10 header** to monitor all of the control and feedback signals of the power stage. This includes all of the logic inputs and outputs of the DRV8305-Q1; the SPI bus, the motor voltage, and current feedback voltages. The 0-Ω resistor banks allow the user to completely disconnect the C2000 MCU and supply their own control inputs.

7. Power Stage Test Points

All signals in the power stage are brought to loop test points for easy monitoring. These test points include the MOSFET gate, drain, source pins, the motor outputs, and the current sense resistors.

2 Demo Application

The DRV8305-Q1EVM provides a motor control example through the MotorWare software repository utilizing InstaSPIN-FOC on the TMS320F28027F Piccolo Microcontroller. InstaSPIN-FOC provides a sensorless, field-oriented motor control solution compatible across a wide range of motors. This section covers setting up the hardware, configuring MotorWare for the DRV8305-Q1EVM, and a quick walkthrough of the InstaSPIN GUI.

2.1 Hardware Setup

Use the following steps to set up the hardware:

- Step 1. Ensure the proper configuration of the jumpers. See the previous section for more details.
- Step 2. Connect the motor phase wires to the **terminal block header H14**. Order does not matter. If the motor is spinning in the wrong direction, two of the motor phases can be swapped to reverse the direction.
- Step 3. Connect the power supply to the **terminal block header H12**. Ensure the proper polarity, positive to VBAT, negative to GND. Do **not** enable the power supply at this time.
- Step 4. Connect the micro-USB cable to **USB connector H9**. A cable is supplied with the DRV8305-Q1EVM and any standard micro-USB cable should also work. Do **not** connect to the PC at this time.
- Step 5. Enable the power supply. The VBAT power supply **LED D4** and 3.3-V power supply, **LED D5** should light up.
- Step 6. Connect the micro-USB cable to the PC in order to run the GUI and interface to the DRV8305-Q1EVM.

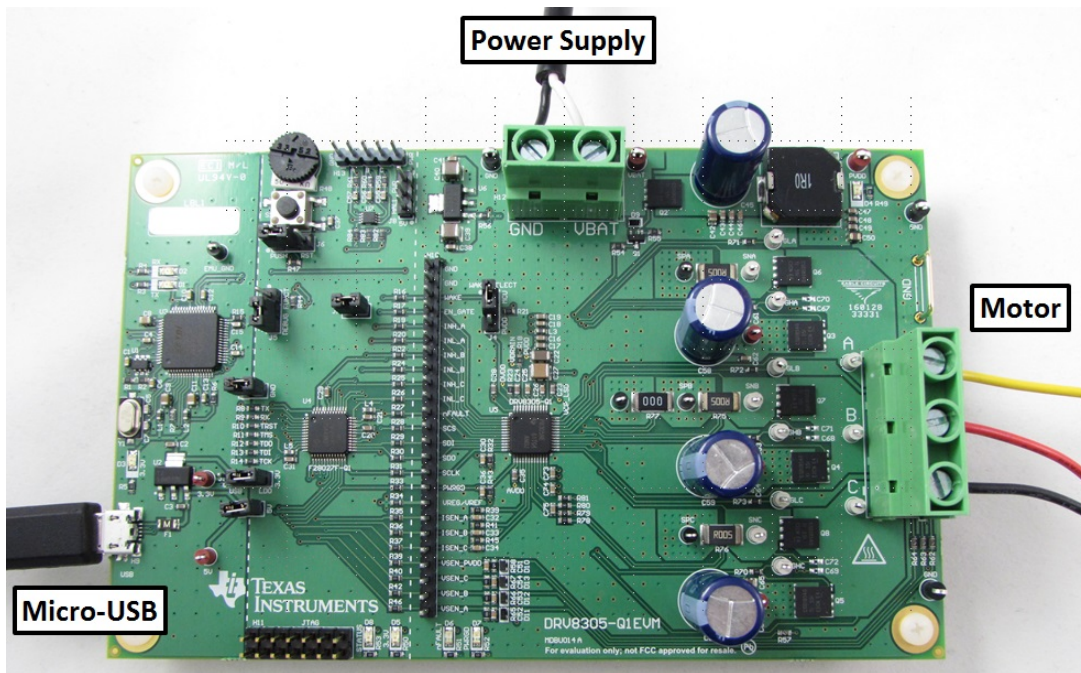

Figure 4. Board Jumpers and Test Points

2.2 MotorWare (InstaSPIN-FOC) Setup

This section shows how to add DRV8305-Q1EVM support to the MotorWare repository allowing the InstaSPIN-FOC motor control solution to be run with the DRV8305-Q1EVM.

1. Download the latest MotorWare software repository available in the software folder <http://www.ti.com/tool/ccstudio>.

TI Home > Semiconductors > Microcontrollers (MCU) > MotorWare™ Software

Worldwide (in English)

MotorWare™ Software

(ACTIVE) MOTORWARE

Description & Features | Technical Documents | Support & Community

Order Now

Part Number	Buy from Texas Instruments or Third Party	Alert Me	Status	Current Version	Version Date	Description
MOTORWARE: MotorWare Software	Free Get Software	Alert Me	ACTIVE	V1.01.00.16	MAR-02-2016	Piccolo InstaSPIN-FOC and InstaSPIN-MOTION software distribution method offers latest in C object oriented and API based coding techniques.

Description

MotorWare™ is a cohesive set of software and technical resources for developing InstaSPIN-FOC™ and InstaSPIN-MOTION™ based applications.

From device-specific drivers and support software to complete system examples and technical training, MotorWare provides support for every stage of development and evaluation.

MotorWare software has been developed to enable easy integration of best-in-class motor control techniques.

This software has been developed to enable:



Motorware GUI

Figure 5. MotorWare Software Home Page

2. Download the latest Code Composer Studio™ version available in the software folder <http://www.ti.com/tool/ccstudio>.
3. Download the DRV8305-Q1EVM software files zip folder available from the tool folder <http://www.ti.com/tool/drv8305-q1evm>.

4. Inside of the zip folder are the additional files (motorware_additions_drv8305-q1evm) needed to add DRV8305-Q1EVM support to MotorWare. The additional files mirror the folder structure of MotorWare they are easily placed in the correct directory.

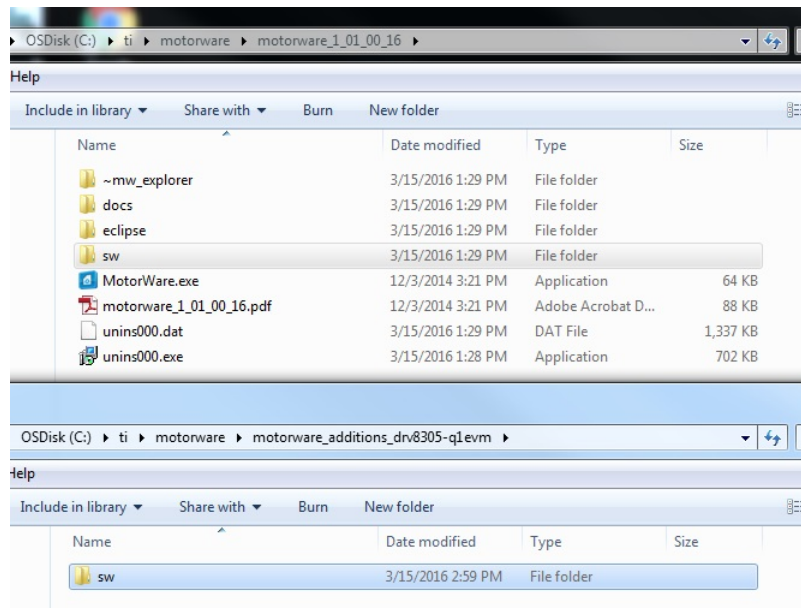

Figure 6. DRV8305-Q1EVM MotorWare Additions

5. Add the hal board files for the DRV8305-Q1EVM to the MotorWare installation. These are located at **motorware_additions_drv8305-q1evm\sw\modules\hal\boards**. Copy the drv8305-q1evm_revA folder into the corresponding folder in the MotorWare repository.

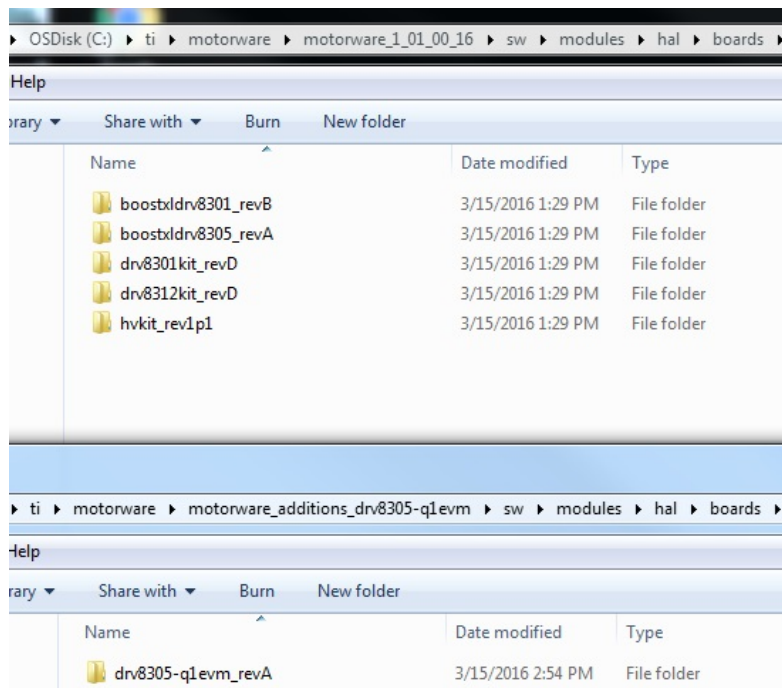

Figure 7. DRV8305-Q1EVM Hal Board Files

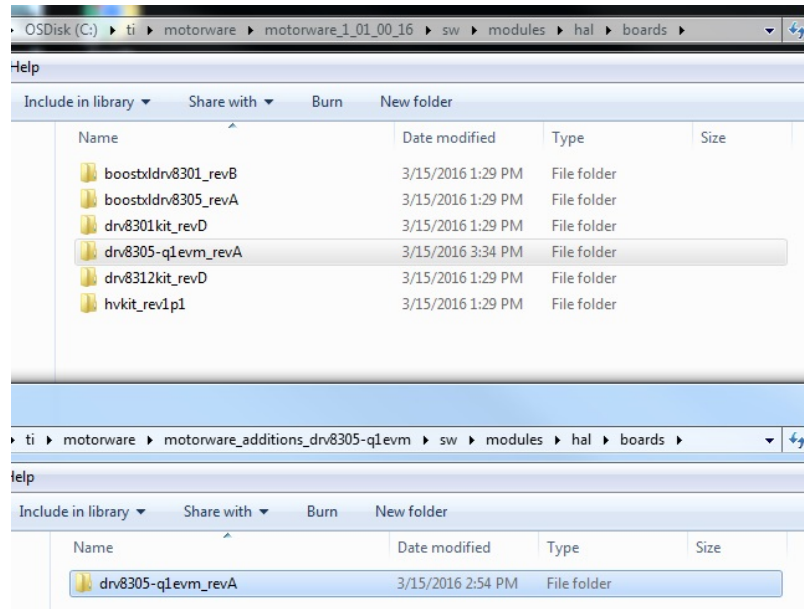

Figure 8. Copied DRV8305-Q1EVM Hal Board Files

6. Add the solutions board files for the DRV8305-Q1EVM to the MotorWare installation. These are located at `motorware_additions_drv8305-q1evm\sw\solutions\instaspin_foc\boards\`. Copy the `drv8305-q1evm_revA` folder into the corresponding folder in the MotorWare repository.

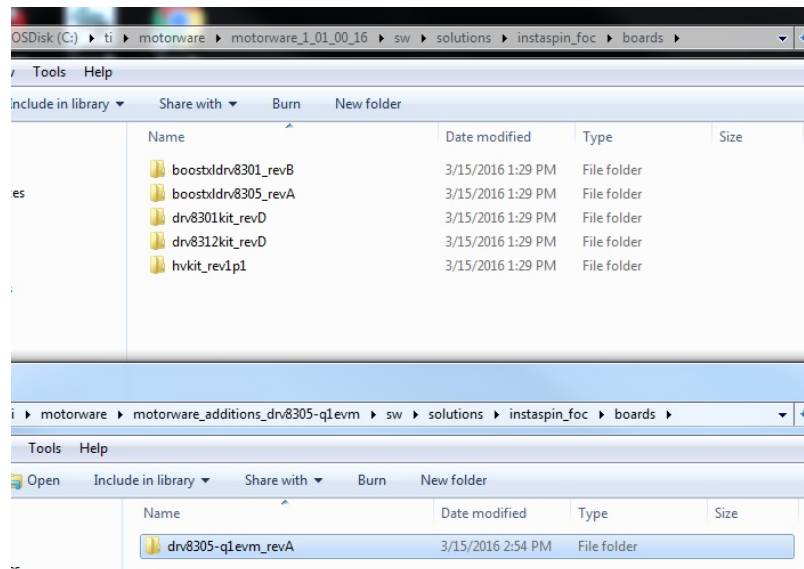

Figure 9. DRV8305-Q1EVM Solutions Board Files

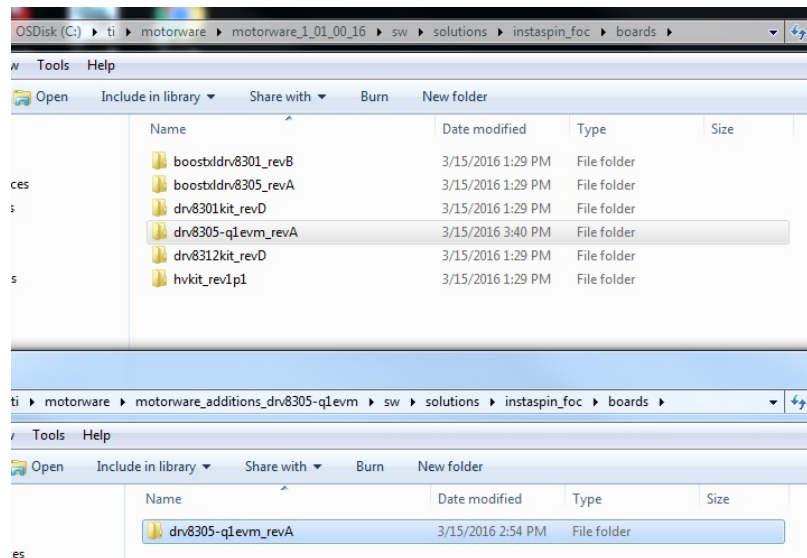

Figure 10. Copied DRV8305-Q1EVM Solutions Board Files

- Verify the addition of the drv8305-q1evm_revA to MotorWare by compiling and loading one of the lab projects in the Code Composer Studio development tool. Import the new CCS projects. Projects are found at **motorware\motorware_x_xx_xx_xx\sw\solutions\instaspin_foc\boards\drv8305-q1evm_revA\28x\2802xF\projects**. Ensure that *Copy projects into workspace* is not selected (MotorWare has relative pathing) and copy all lab projects you wish to evaluate. You can find more information about the individual labs and working in Code Composer Studio at **motorware\motorware_x_xx_xx_xx\docs\labs**.

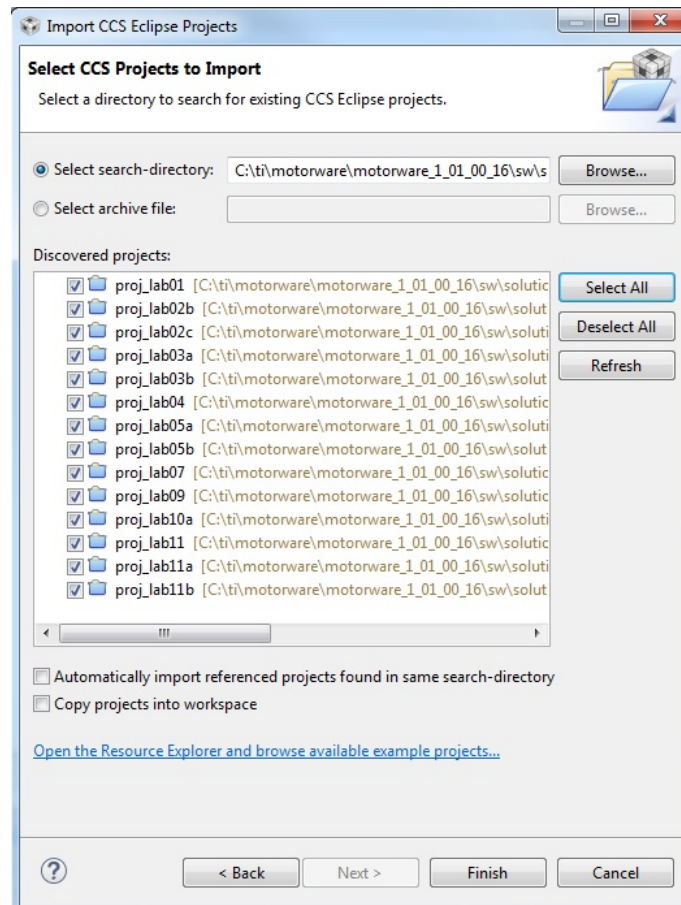

Figure 11. CCS Import

8. To verify the directory setup, compile and load proj_lab01. This is a simple hello world project. Ensure the DRV8305-Q1EVM has power applied. Assuming a successful compile and load to the DRV8305-Q1EVM, the STATUS LED D8 will begin to flash.
9. This completes the MotorWare setup, for further information on MotorWare, InstaSPIN-FOC, and the various labs please refer to the documentation inside of the MotorWare repository.

2.3 InstaSPIN Universal GUI

In addition to interfacing to the InstaSPIN-FOC variables directly through Code Composer Studio, a GUI is provided that can instrument the variables visually. The InstaSPIN Universal GUI instruments the existing variables in any MotorWare InstaSPIN-FOC project, meaning you can recompile the .out to add your own settings and other system code. The InstaSPIN Universal GUI also loads the firmware binary (.out) directly to the DRV8305-Q1EVM before launching the application.

This section outlines setting up the GUI (these instructions are also inside the *GUI Read Me* tab, once launched).

1. Download the latest InstaSPIN Universal GUI available in the software folder <http://www.ti.com/tool/instaspinuniversalgui>.
2. Since the GUI requires the firmware binary (.file) file, first compile the appropriate lab project in Code Composer Studio. The typical first lab is Lab02b. Lab02b focuses on identifying the parameters of the BLDC motor and then running a basic speed loop to control the motor.

- In Code Composer Studio, compile the lab project you wish to work with. After a successful compile, the binary (.out) file is found in the *Binaries* drop-down menu.

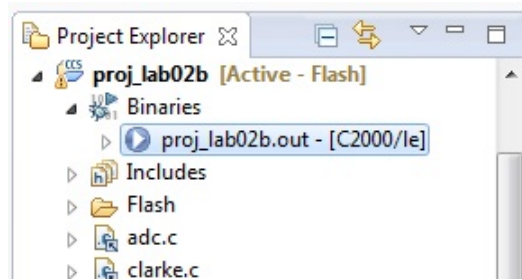

Figure 12. Binary (.out) File Location

- Copy this file into the InstaSPIN Universal GUI folder for the F2802x_F device. The path is typically `INSTALLDIRECTORY\guicomposer\webapps\InstaSPIN_F2802xF_UNIVERSAL\`.

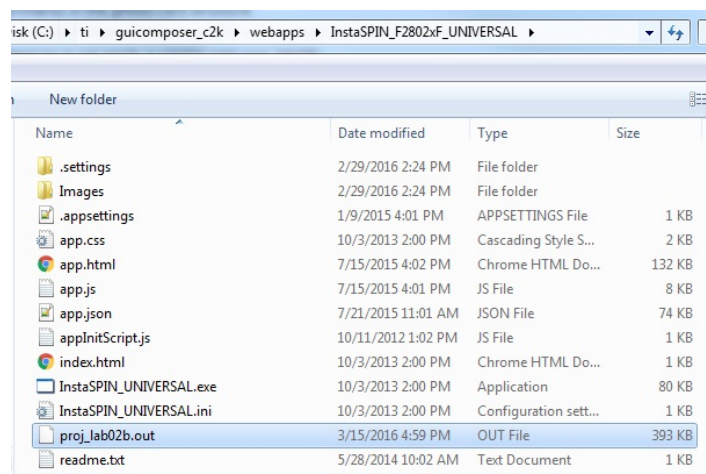

Figure 13. Place Binary (.out) File With GUI

- Rename the binary (.out) file to `appProgram.out`. The GUI searches for this filename.

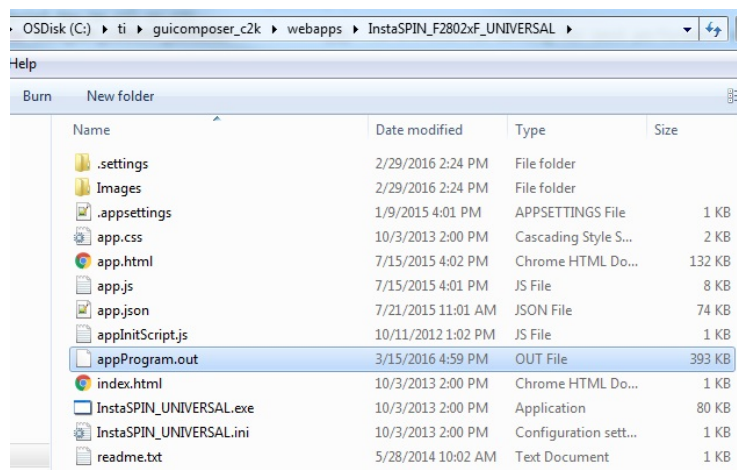

Figure 14. Rename Binary (.out) File

- Launch the GUI through the **InstaSPIN_UNIVERSAL.exe** file. The GUI first programs the DRV8305-Q1EVM and then loads the application. Ensure that the debugger connection in Code Composer Studio is closed so that the interface is free for the GUI. If you encounter an issue when loading the GUI, power down the EVM and remove the USB cable. Reconnect and try again.

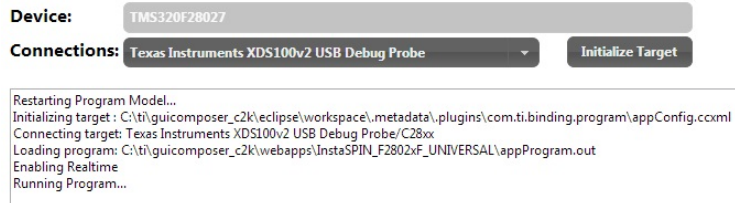

Figure 15. Launch GUI

- To begin the motor identification process in Lab2b, select *Enable System* and then *Run*. The motor begins to walk through a series of steps to identify the different parameters.

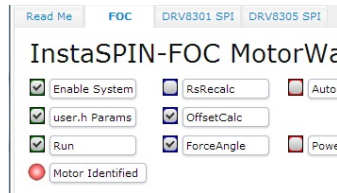

Figure 16. Enable Motor Identification

- After a successful identification, select *Run* again and the motor begins to run with a basic speed loop to the speed and acceleration that are specified.

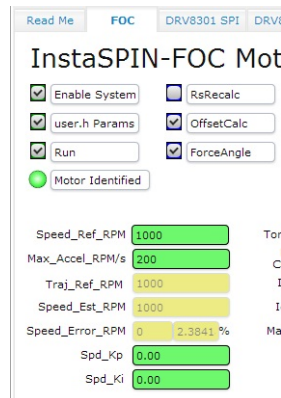

Figure 17. Enable Motor

- Any time after *Enable System* is selected, you can interface to the DRV8305 SPI registers through the InstaSPIN Universal GUI. The registers do not automatically update and must be read or written to in order to update the DRV8305 and register page.

Read Me
FOC
DRV8301 SPI
DRV8305 SPI

Note: Only enabled for DRV8305 hardware

	10	9	8	7	6	5	4	3	2	1	0
Status Register 0x01	FAULT	RSVD	TEMP_FLG4	PVDD_UVFL	PVDD_OVFL	VDS_STAT	VCPH_UVFL	TEMP_FLG1	TEMP_FLG2	TEMP_FLG3	OTW
	<input type="text" value="0"/>	<input type="text" value="0"/>	<input type="text" value="0"/>	<input type="text" value="0"/>	<input type="text" value="0"/>	<input type="text" value="0"/>	<input type="text" value="0"/>	<input type="text" value="0"/>	<input type="text" value="0"/>	<input type="text" value="0"/>	<input type="text" value="0"/>
Status Register 0x02	FETHA_VDS	FETLA_VDS	FETBH_VDS	FETLB_VDS	FETHC_VDS	FETLC_VDS	RSVD	RSVD	SNS_C_OCP	SNS_B_OCP	SNS_A_OCP
	<input type="text" value="0"/>	<input type="text" value="0"/>	<input type="text" value="0"/>	<input type="text" value="0"/>	<input type="text" value="0"/>	<input type="text" value="0"/>	<input type="text" value="0"/>	<input type="text" value="0"/>	<input type="text" value="0"/>	<input type="text" value="0"/>	<input type="text" value="0"/>
Status Register 0x03	PVDD_UVLO2	WD_FAULT	OTS	RSVD	VREG_UV	AVDD_UVLO	VCPH_UVLO2	RSVD	VCPH_UVLO2	VCPH_OVLO	VCPH_OVLO_ABS
	<input type="text" value="0"/>	<input type="text" value="0"/>	<input type="text" value="0"/>	<input type="text" value="0"/>	<input type="text" value="0"/>	<input type="text" value="0"/>	<input type="text" value="0"/>	<input type="text" value="0"/>	<input type="text" value="0"/>	<input type="text" value="0"/>	<input type="text" value="0"/>
Status Register 0x04	FETHA_VGS	FETLA_VGS	FETBH_VGS	FETLB_VGS	FETHC_VGS	FETLC_VGS	RSVD	RSVD	RSVD	RSVD	RSVD
	<input type="text" value="0"/>	<input type="text" value="0"/>	<input type="text" value="0"/>	<input type="text" value="0"/>	<input type="text" value="0"/>	<input type="text" value="0"/>	<input type="text" value="0"/>	<input type="text" value="0"/>	<input type="text" value="0"/>	<input type="text" value="0"/>	<input type="text" value="0"/>
Control Register 0x05	RSVD	TDRIVEN	IDRIVEN_HS				IDRIVEP_HS				
	<input type="text" value="0"/>	<input type="text" value="0"/>	<input type="text" value="ISink_HS_0p050_A"/>				<input type="text" value="ISour_HS_0p050_A"/>				
Control Register 0x06	RSVD	TDRIVEP	IDRIVEN_LS				IDRIVEP_LS				
	<input type="text" value="0"/>	<input type="text" value="0"/>	<input type="text" value="ISink_HS_0p050_A"/>				<input type="text" value="ISour_HS_0p050_A"/>				
Control Register 0x07	RSVD	COMM_OPT	PWM_MODE	DEAD_TIME			TBLANK		TVDS		
	<input type="text" value="0"/>	<input type="text" value="Actv"/>	<input type="text" value="PwmMode_6"/>	<input type="text" value="DeadTime_60_ns"/>			<input type="text" value="VDSBlnk_2_us"/>		<input type="text" value="VDSDeg_4_us"/>		
Control Register 0x09	FLIP_OTS	DIS_UVLO2	DIS_FAULT	EN_SNS_CLAMP	WD_DLY	DIS_SNS_OCP	WD_EN	SLEEP	CLR_FLTS	SET_VCPH_UV	
	<input type="text" value="0"/>	<input type="text" value="0"/>	<input type="text" value="0"/>	<input type="text" value="0"/>	<input type="text" value="WD_Dly_20_ms"/>	<input type="text" value="0"/>	<input type="text" value="0"/>	<input type="text" value="0"/>	<input type="text" value="0"/>	<input type="text" value="0"/>	
Control Register 0x0A	CAL_CH3	CAL_CH2	CAL_CH1	CS_BLANK	GAIN_CS3		GAIN_CS2		GAIN_CS1		
	<input type="text" value="0"/>	<input type="text" value="0"/>	<input type="text" value="0"/>	<input type="text" value="Blank_0p00_us"/>	<input type="text" value="Gain3_10VpV"/>		<input type="text" value="Gain2_10VpV"/>		<input type="text" value="Gain1_10VpV"/>		
Control Register 0x0B	RSVD	VREF_SCALING	RSVD	RSVD	RSVD	SLEEP_DLY	DIS_PWRGD	VREG_UV_LEVEL			
	<input type="text" value="0"/>	<input type="text" value="Scaling_k_2"/>	<input type="text" value="0"/>	<input type="text" value="0"/>	<input type="text" value="0"/>	<input type="text" value="SleepDly_10_us"/>	<input type="text" value="0"/>	<input type="text" value="UvLevel_30"/>			
Control Register 0x0C	RSVD	RSVD	RSVD	VDS_LEVEL				VDS_MODE			
	<input type="text" value="0"/>	<input type="text" value="0"/>	<input type="text" value="0"/>	<input type="text" value="VDS_Level__1p175_V"/>				<input type="text" value="Latched_Shutdown"/>			

Addr. (Dec)

Write Data (Dec)

Addr. (Dec)

Read Data (Dec)

Figure 18. DRV8305 SPI Registers

3 DRV8305-Q1EVM

All of the hardware source files are found at the DRV8305-Q1EVM tool folder <http://www.ti.com/tool/drv8305-q1evm> in the download file for the DRV8305-Q1EVM Hardware Files.

3.1 DRV8305-Q1EVM Schematics

Figure 19 through Figure 22 show the EVM schematics.

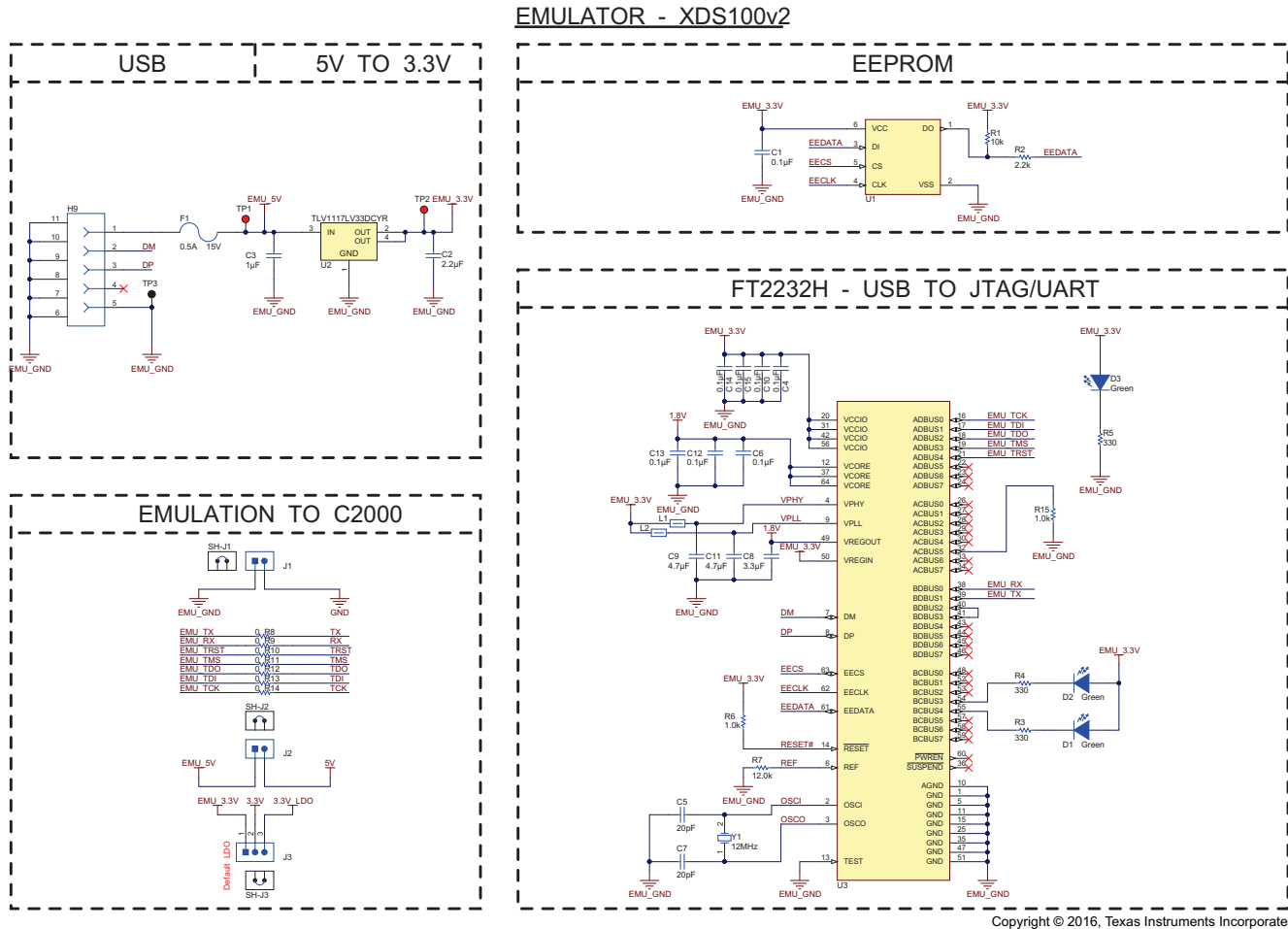
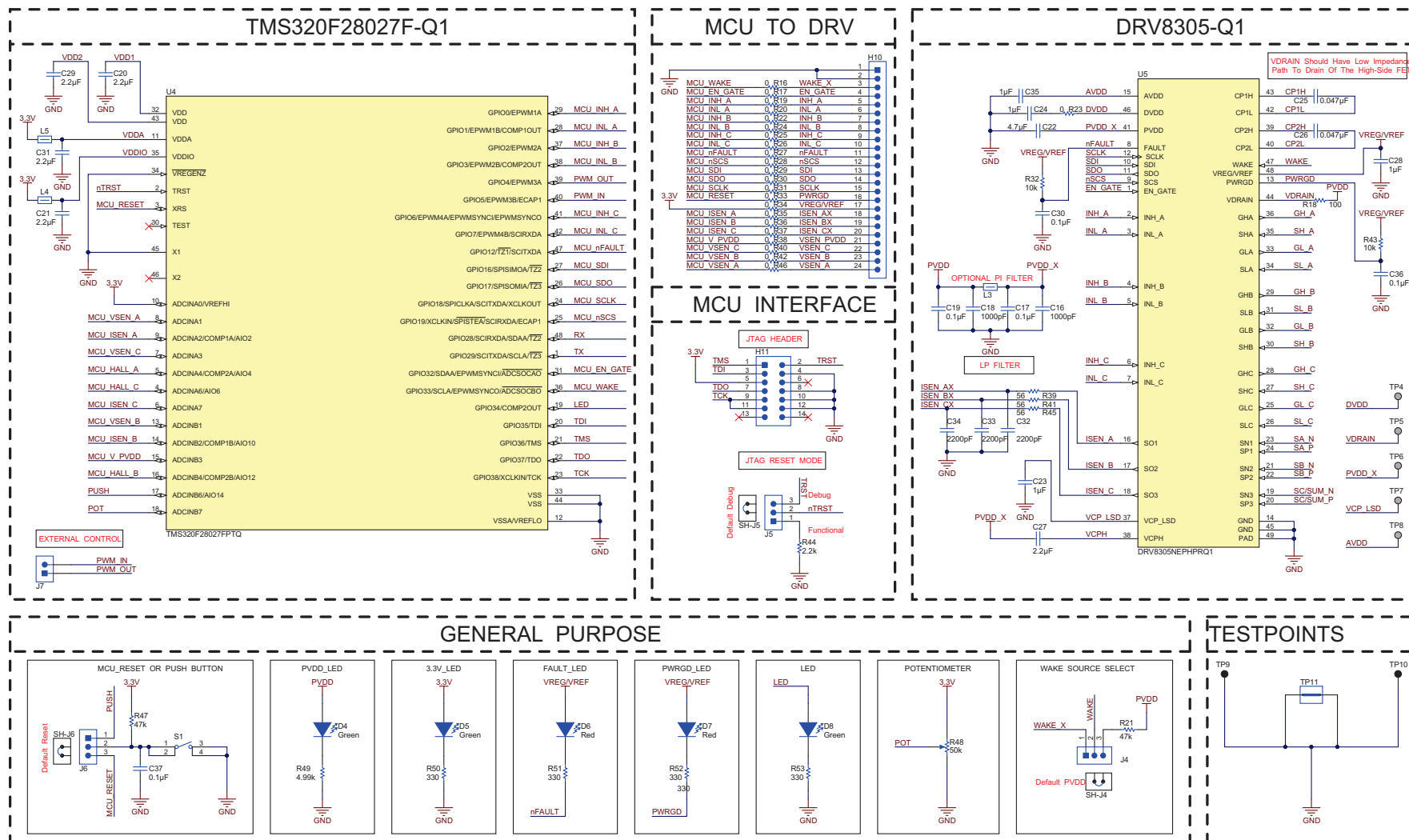

Figure 19. DRV8305-Q1EVM Emulator Schematic

Copyright © 2016, Texas Instruments Incorporated



Copyright © 2016, Texas Instruments Incorporated

Figure 20. DRV8305-Q1EVM MCU DRV Schematic

CONNECTORS/DRIVE-STAGE

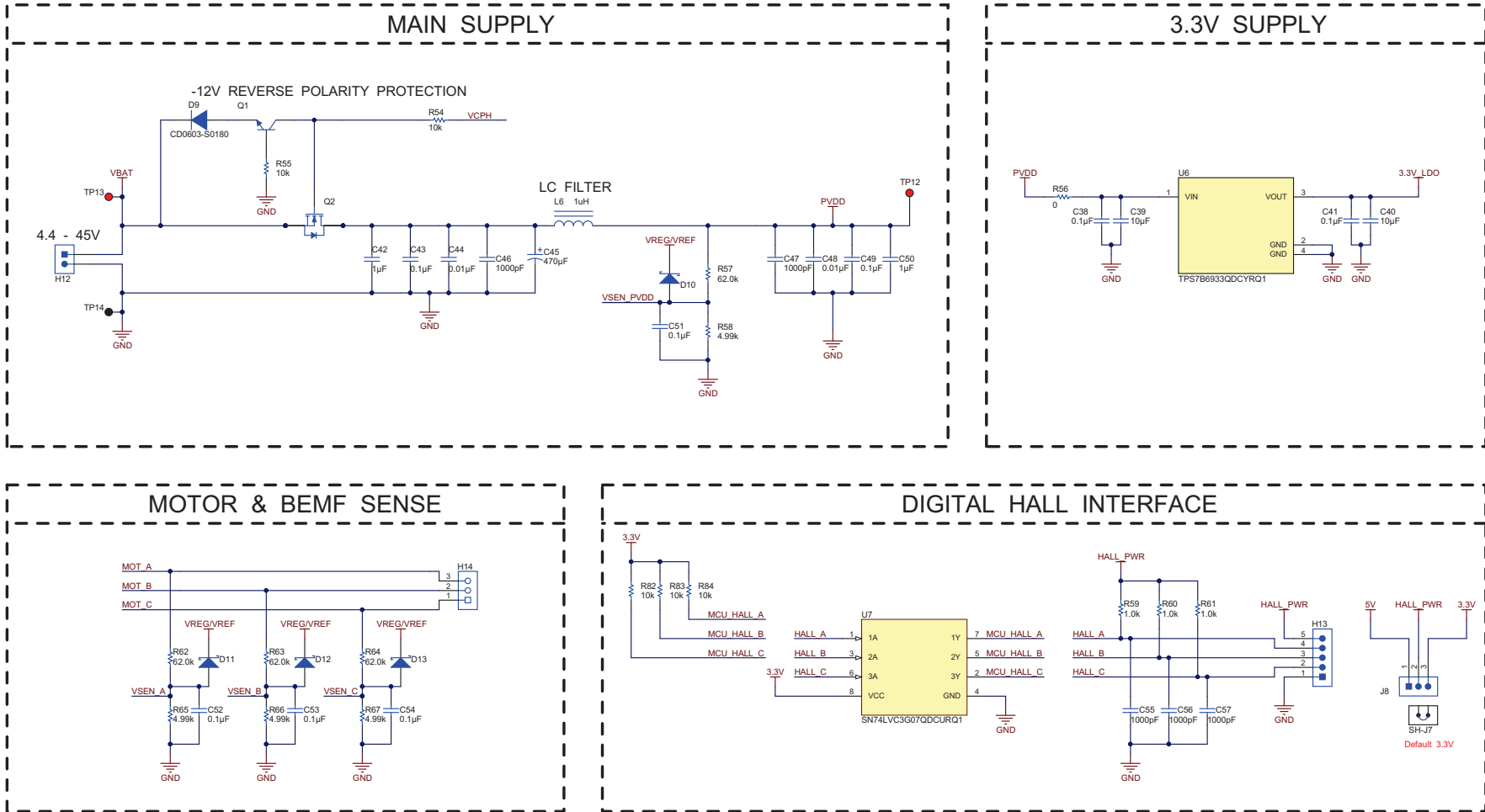

Copyright © 2016, Texas Instruments Incorporated

Figure 21. DRV8305-Q1EVM Power Schematic

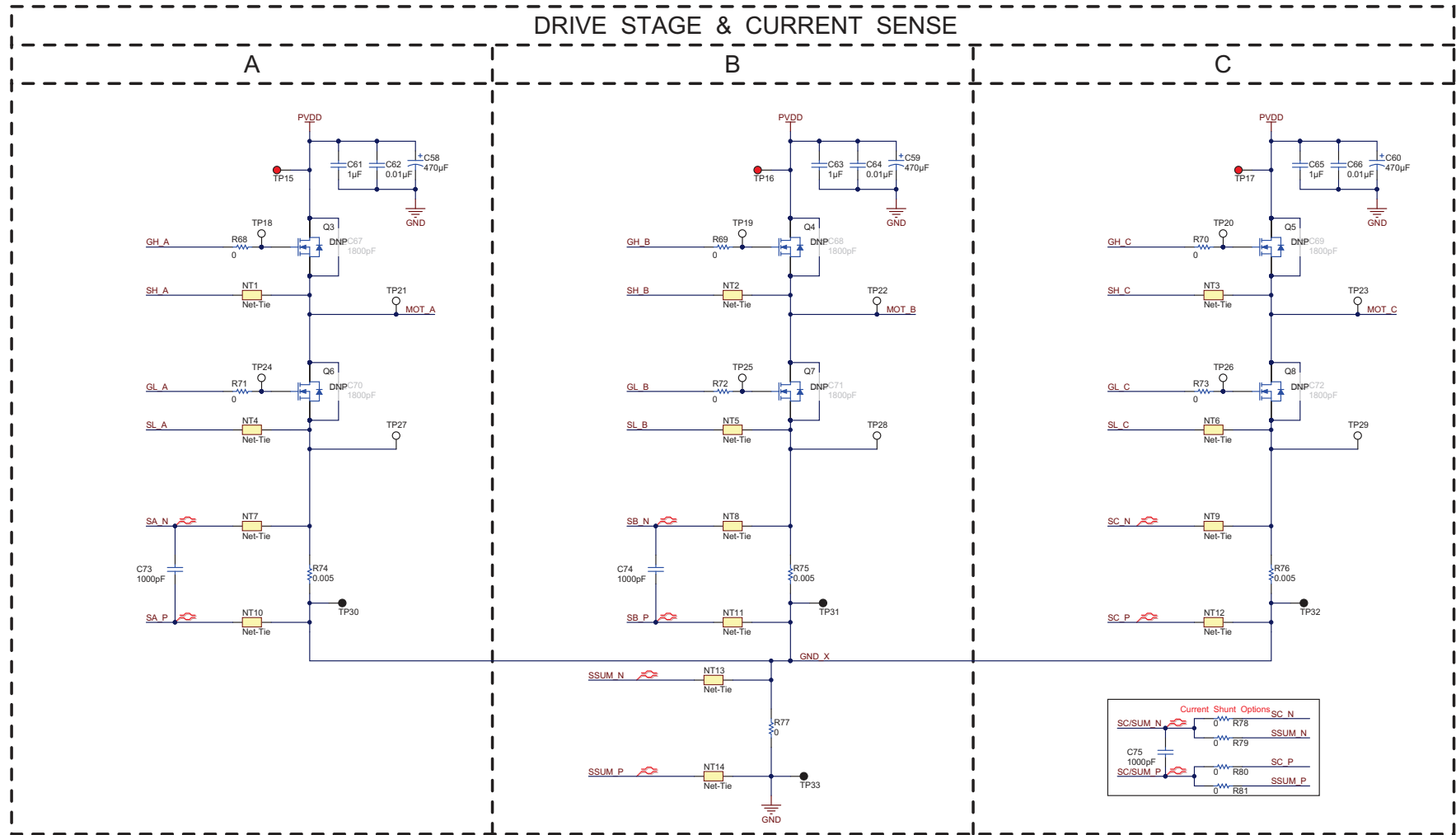

Copyright © 2016, Texas Instruments Incorporated

Figure 22. DRV8305-Q1EVM Bridges Schematic

3.2 DRV8305-Q1EVM Bill of Materials

Figure 22 lists the EVM bill of materials.

Table 1. DRV8305-Q1EVM Bill of Materials

Designator	Qty	Value	Description	Package Reference	Part Number	Manufacturer	Alternate Part Number	Alternate Manufacturer
IPCB1	1		Printed Circuit Board		MDBU014	Any		
C1, C4, C6, C10, C12, C13, C14, C15, C30, C36, C37	11	0.1uF	CAP, CERM, 0.1 μF, 10 V, ±10%, X7R, 0603	0603	C0603C104K8RACTU	Kemet		
C2, C20, C21, C29, C31	5	2.2uF	CAP, CERM, 2.2 μF, 10 V, ±10%, X7R, 0603	0603	GRM188R71A225KE15D	Murata		
C3, C23, C24, C28, C35	5	1uF	CAP, CERM, 1 μF, 16 V, ±10%, X7R, 0603	0603	C1608X7R1C105K	TDK		
C5, C7	2	20pF	CAP, CERM, 20 pF, 50 V, ±5%, C0G/NP0, 0603	0603	GRM1885C1H200JA01D	Murata		
C8	1	3.3uF	CAP, CERM, 3.3 μF, 10 V, ±10%, X7R, 0805	0805	GRM21BR71A335KA99L	Murata		
C9, C11	2	4.7uF	CAP, CERM, 4.7 μF, 10 V, ±10%, X7R, 0805	0805	GRM21BR71A475KA73L	Murata		
C16, C18, C46, C47	4	1000pF	CAP, CERM, 1000 pF, 50 V, ±10%, X7R, 0603	0603	C1608X7R1H102K	TDK		
C17, C19, C38, C41, C43, C49	6	0.1uF	CAP, CERM, 0.1 μF, 50 V, ±10%, X7R, 0603	0603	C1608X7R1H104K	TDK		
C22	1	4.7uF	CAP, CERM, 4.7 μF, 50 V, ±10%, X7R, 1206	1206	GRM31CR71H475KA12L	Murata		
C25	1	0.047uF	CAP, CERM, 0.047 μF, 50 V, ±10%, X7R, 0603	0603	C1608X7R1H473K	TDK		
C26	1	0.047uF	CAP, CERM, 0.047 μF, 100 V, ±10%, X7R, 0603	0603	C0603C473K1RACTU	Kemet		
C27	1	2.2uF	CAP, CERM, 2.2 μF, 100 V, ±10%, X7R, 1210	1210	GRM32ER72A225KA35L	Murata		
C32, C33, C34	3	2200pF	CAP, CERM, 2200 pF, 16 V, ±10%, X7R, 0603	0603	GRM188R71C222KA01D	Murata		
C39, C40	2	10uF	CAP, CERM, 10 μF, 50 V, ±10%, X7R, 1210	1210	GRM32ER71H106KA12L	Murata		
C42, C50, C61, C63, C65	5	1uF	CAP, CERM, 1 μF, 50 V, ±10%, X7R, 0805	0805	GRM21BR71H105KA12L	Murata		
C44, C48	2	0.01uF	CAP, CERM, 0.01 μF, 50 V, ±10%, X7R, 0603	0603	C1608X7R1H103K	TDK		
C45, C58, C59, C60	4	470uF	CAP, AL, 470 μF, 50 V, ±20%, TH	10x20	ECA-1HM471	Panasonic		
C51, C52, C53, C54	4	0.1uF	CAP, CERM, 0.1 μF, 16 V, ±5%, X7R, 0603	0603	C0603C104J4RACTU	Kemet		
C55, C56, C57, C73, C74, C75	6	1000pF	CAP, CERM, 1000 pF, 16 V, ±10%, X7R, 0603	0603	GRM188R71C102KA01D	Murata		
C62, C64, C66	3	0.01uF	CAP, CERM, 0.01 μF, 50 V, ±10%, X8R, 0603	0603	C1608X8R1H103K	TDK		
D1, D2, D3, D4, D5, D8	6	Green	LED, Green, SMD	LED_0805	LTST-C171GKT	Lite-On		
D6, D7	2	Red	LED, Red, SMD	LED_0805	LTST-C170KRKT	Lite-On		
D9	1	90V	Diode, Switching, 90 V, 0.1 A, 0603 Diode	0603 Diode	CD0603-S0180	Bourns		
D10, D11, D12, D13	4	35V	Diode, Schottky, 35 V, 0.1 A, 0603 Diode	0603 Diode	CD0603-B0130L	Bourns		
F1	1		PTC RESET 15V .500A SMD 1206	1206	1206L050/15YR	Littelfuse		
H1, H2, H5, H6	4		Standoff, Hex, 0.5"L #4-40 Nylon	Standoff	1902C	Keystone		
H3, H4, H7, H8	4		Machine Screw, Round, #4-40 x 1/4, Nylon, Philips panhead	Screw	NY PMS 440 0025 PH	B&F Fastener Supply		
H9	1		Connector, micro USB Type B, Receptacle, R/A, SMD	Micro USB-B receptacle	ZX62-B-5PA(11)	Hirose Electric Co. Ltd.		
H10	1		Header, 2.54mm, 24x1, Gold, TH	Header, 2.54mm, 24x1, TH	PEC24SAAN	Sullins Connector Solutions		
H11	1		Header, 100mil, 7x2, Gold, TH	7x2 Header	TSW-107-07-G-D	Samtec		
H12	1		Terminal Block, 30A, 9.52mm (.375) Pitch, 2-Pos, TH	19.62x21.5x12.5mm	OSTT7022150	On-Shore Technology		
H13	1		Header, 2.54mm, 5x1, Tin, TH	Header, 2.54mm, 5x1, TH	PEC05SAAN	Sullins Connector Solutions		

Table 1. DRV8305-Q1EVM Bill of Materials (continued)

Designator	Qty	Value	Description	Package Reference	Part Number	Manufacturer	Alternate Part Number	Alternate Manufacturer
H14	1		Terminal Block, 3x1, 9.52mm, TH	Terminal Block, 3x1, 9.52mm, TH	OSTT7032150	On-Shore Technology		
J1, J2, J7	3		Header, 100mil, 2x1, Tin, TH	Header, 2 PIN, 100mil, Tin	PEC02SAAN	Sullins Connector Solutions		
J3, J4, J5, J6, J8	5		Header, 100mil, 3x1, Tin, TH	Header, 3 PIN, 100mil, Tin	PEC03SAAN	Sullins Connector Solutions		
L1, L2, L3, L4, L5	5	330 ohm	FERRITE CHIP 330 OHM 1200MA 0603	0603	BLM18PG331SH1D	Murata		
L6	1	1uH	Inductor, Powdered Iron, 1 µH, 29 A, 0.0025 ohm, SMD	13.9x5.9x13.5mm	SRP1250-1R0M	Bourns		
LBL1	1		Thermal Transfer Printable Labels, 0.650" W x 0.200" H - 10,000 per roll	PCB Label 0.650"H x 0.200"W	THT-14-423-10	Brady		
Q1	1	65 V	Transistor, NPN, 65 V, 0.1 A, SOT-23	SOT-23	BC846BLT1G	ON Semiconductor		
Q2, Q3, Q4, Q5, Q6, Q7, Q8	7	60V	MOSFET, N-CH, 60 V, 28 A, SON 5x6mm	SON 5x6mm	CSD18540Q5B	Texas Instruments		None
R1, R32, R43, R54, R55, R82, R83, R84	8	10k	RES, 10 k, 5%, 0.1 W, 0603	0603	CRCW060310K0JNEA	Vishay-Dale		
R2, R44	2	2.2k	RES, 2.2 k, 5%, 0.1 W, 0603	0603	CRCW06032K20JNEA	Vishay-Dale		
R3, R4, R5, R50, R51, R52, R53	7	330	RES, 330, 5%, 0.1 W, 0603	0603	CRCW0603330RJNEA	Vishay-Dale		
R6, R15, R59, R60, R61	5	1.0k	RES, 1.0 k, 5%, 0.1 W, 0603	0603	CRCW06031K00JNEA	Vishay-Dale		
R7	1	12.0k	RES, 12.0 k, 1%, 0.1 W, 0603	0603	RC0603FR-0712KL	Yageo America		
R8, R9, R10, R11, R12, R13, R14, R16, R17, R19, R20, R22, R23, R24, R25, R26, R27, R28, R29, R30, R31, R33, R34, R35, R36, R37, R38, R40, R42, R46, R56, R68, R69, R70, R71, R72, R73, R78, R79, R80, R81	41	0	RES, 0, 5%, 0.1 W, 0603	0603	CRCW06030000Z0EA	Vishay-Dale		
R18	1	100	RES, 100, 5%, 0.1 W, 0603	0603	CRCW0603100RJNEA	Vishay-Dale		
R21, R47	2	47k	RES, 47 k, 5%, 0.1 W, 0603	0603	CRCW060347K0JNEA	Vishay-Dale		
R39, R41, R45	3	56	RES, 56, 5%, 0.1 W, 0603	0603	CRCW060356R0JNEA	Vishay-Dale		
R48	1	50k	Trimming Potentiometer, 50K, 0.5W, TH	9.53x8.89mm	3352T-1-503LF	Bourns		
R49, R58, R65, R66, R67	5	4.99k	RES, 4.99 k, 1%, 0.1 W, 0603	0603	CRCW06034K99FKEA	Vishay-Dale		
R57, R62, R63, R64	4	62.0k	RES, 62.0 k, 1%, 0.1 W, 0603	0603	RC0603FR-0762KL	Yageo America		
R74, R75, R76	3	0.005	RES SMD 0.005 OHM 1% 3W 2512	2512	LRMAP2512-R005FT4	TT Electronics/Welwyn		
R77	1	0	RES, 0, 5%, 1.5 W, AEC-Q200 Grade 0, 2512	2512	CRCW25120000Z0EGHP	Vishay-Dale		
S1	1		Switch, Tactile, SPST-NO, 0.05A, 12V, SMT	SW, SPST 6x6 mm	4-1437565-1	TE Connectivity		
SH-J1, SH-J2, SH-J3, SH-J4, SH-J5, SH-J6, SH-J7	7	1x2	Shunt, 100mil, Gold plated, Black	Shunt	969102-0000-DA	3M	SNT-100-BK-G	Samtec
TP1, TP2, TP15, TP16, TP17	5	Red	Test Point, Miniature, Red, TH	Red Miniature Testpoint	5000	Keystone		
TP3, TP30, TP31, TP32, TP33	5	Black	Test Point, Miniature, Black, TH	Black Miniature Testpoint	5001	Keystone		
TP9, TP10, TP14	3	Black	Test Point, Compact, Black, TH	Black Compact Testpoint	5006	Keystone		
TP11	1		1mm Uninsulated Shorting Plug, 10.16mm spacing, TH	Shorting Plug, 10.16mm spacing, TH	D3082-05	Harwin		

Table 1. DRV8305-Q1EVM Bill of Materials (continued)

Designator	Qty	Value	Description	Package Reference	Part Number	Manufacturer	Alternate Part Number	Alternate Manufacturer
TP12, TP13	2	Red	Test Point, Compact, Red, TH	Red Compact Testpoint	5005	Keystone		
TP18, TP19, TP20, TP21, TP22, TP23, TP24, TP25, TP26, TP27, TP28, TP29	12	White	Test Point, Miniature, White, TH	White Miniature Testpoint	5002	Keystone		
U1	1		2K Microwire Compatible Serial EEPROM, SOT-23-6	SOT-23-6	93LC56BT-I/OT	Microchip		
U2	1		Single Output LDO, 1 A, Fixed 3.3 V Output, 2 to 5.5 V Input, 4-pin SOT-223 (DCY), -40 to 125 degC, Green (RoHS & no Sb/Br)	DCY0004A	TLV1117LV33DCYR	Texas Instruments	Equivalent	Texas Instruments
U3	1		Dual High Speed USB To Multipurpose UART/FIFO IC, LQFP-64	LQFP_10x10mm	FT2232HL-REEL	FTDI		
U4	1		Piccolo Microcontroller, PT0048A	PT0048A	TMS320F28027FPTQ	Texas Instruments	TMS320F28027FPTT	Texas Instruments
U5	1		Three Phase Automotive Gate Driver with Three Integrated Current Shunt Amplifiers and Voltage Regulator, PHP0048G	PHP0048G	DRV8305NEPHRQ1	Texas Instruments	DRV8305NEHPQ1	Texas Instruments
U6	1		High Voltage Ultra Low Iq - Low Drop Out Regulator, DCY0004A	DCY0004A	TPS7B6933QDCYRQ1	Texas Instruments		Texas Instruments
U7	1		TRIPLE BUFFER/DRIVER WITH OPEN-DRAIN OUTPUTS, DCU0008A	DCU0008A	SN74LVC3G07QDCURQ1	Texas Instruments		Texas Instruments
Y1	1		CRYSTAL, 12MHz, 20pF, SMD	7x2.3x4.1mm	ECS-120-20-3X-TR	ECS Inc.		
C67, C68, C69, C70, C71, C72	0	1800pF	CAP, CERM, 1800 pF, 100 V, ±10%, X7R, 0603	0603	GRM188R72A182KA01D	Murata		
FID1, FID2, FID3	0		Fiducial mark. There is nothing to buy or mount.	N/A	N/A	N/A		
Notes:		Unless otherwise noted in the Alternate PartNumber and/or Alternate Manufacturer columns, all parts may be substituted with equivalents.						

Revision History

NOTE: Page numbers for previous revisions may differ from page numbers in the current version.

Changes from Original (April) to A Revision	Page
• Added the hot surfaces warning.....	2

STANDARD TERMS AND CONDITIONS FOR EVALUATION MODULES

1. *Delivery:* TI delivers TI evaluation boards, kits, or modules, including any accompanying demonstration software, components, or documentation (collectively, an "EVM" or "EVMs") to the User ("User") in accordance with the terms and conditions set forth herein. Acceptance of the EVM is expressly subject to the following terms and conditions.
 - 1.1 EVMs are intended solely for product or software developers for use in a research and development setting to facilitate feasibility evaluation, experimentation, or scientific analysis of TI semiconductors products. EVMs have no direct function and are not finished products. EVMs shall not be directly or indirectly assembled as a part or subassembly in any finished product. For clarification, any software or software tools provided with the EVM ("Software") shall not be subject to the terms and conditions set forth herein but rather shall be subject to the applicable terms and conditions that accompany such Software
 - 1.2 EVMs are not intended for consumer or household use. EVMs may not be sold, sublicensed, leased, rented, loaned, assigned, or otherwise distributed for commercial purposes by Users, in whole or in part, or used in any finished product or production system.
2. *Limited Warranty and Related Remedies/Disclaimers:*
 - 2.1 These terms and conditions do not apply to Software. The warranty, if any, for Software is covered in the applicable Software License Agreement.
 - 2.2 TI warrants that the TI EVM will conform to TI's published specifications for ninety (90) days after the date TI delivers such EVM to User. Notwithstanding the foregoing, TI shall not be liable for any defects that are caused by neglect, misuse or mistreatment by an entity other than TI, including improper installation or testing, or for any EVMs that have been altered or modified in any way by an entity other than TI. Moreover, TI shall not be liable for any defects that result from User's design, specifications or instructions for such EVMs. Testing and other quality control techniques are used to the extent TI deems necessary or as mandated by government requirements. TI does not test all parameters of each EVM.
 - 2.3 If any EVM fails to conform to the warranty set forth above, TI's sole liability shall be at its option to repair or replace such EVM, or credit User's account for such EVM. TI's liability under this warranty shall be limited to EVMs that are returned during the warranty period to the address designated by TI and that are determined by TI not to conform to such warranty. If TI elects to repair or replace such EVM, TI shall have a reasonable time to repair such EVM or provide replacements. Repaired EVMs shall be warranted for the remainder of the original warranty period. Replaced EVMs shall be warranted for a new full ninety (90) day warranty period.
3. *Regulatory Notices:*
 - 3.1 *United States*
 - 3.1.1 *Notice applicable to EVMs not FCC-Approved:*

This kit is designed to allow product developers to evaluate electronic components, circuitry, or software associated with the kit to determine whether to incorporate such items in a finished product and software developers to write software applications for use with the end product. This kit is not a finished product and when assembled may not be resold or otherwise marketed unless all required FCC equipment authorizations are first obtained. Operation is subject to the condition that this product not cause harmful interference to licensed radio stations and that this product accept harmful interference. Unless the assembled kit is designed to operate under part 15, part 18 or part 95 of this chapter, the operator of the kit must operate under the authority of an FCC license holder or must secure an experimental authorization under part 5 of this chapter.
 - 3.1.2 *For EVMs annotated as FCC – FEDERAL COMMUNICATIONS COMMISSION Part 15 Compliant:*

CAUTION

This device complies with part 15 of the FCC Rules. Operation is subject to the following two conditions: (1) This device may not cause harmful interference, and (2) this device must accept any interference received, including interference that may cause undesired operation.

Changes or modifications not expressly approved by the party responsible for compliance could void the user's authority to operate the equipment.

FCC Interference Statement for Class A EVM devices

NOTE: This equipment has been tested and found to comply with the limits for a Class A digital device, pursuant to part 15 of the FCC Rules. These limits are designed to provide reasonable protection against harmful interference when the equipment is operated in a commercial environment. This equipment generates, uses, and can radiate radio frequency energy and, if not installed and used in accordance with the instruction manual, may cause harmful interference to radio communications. Operation of this equipment in a residential area is likely to cause harmful interference in which case the user will be required to correct the interference at his own expense.

FCC Interference Statement for Class B EVM devices

NOTE: This equipment has been tested and found to comply with the limits for a Class B digital device, pursuant to part 15 of the FCC Rules. These limits are designed to provide reasonable protection against harmful interference in a residential installation. This equipment generates, uses and can radiate radio frequency energy and, if not installed and used in accordance with the instructions, may cause harmful interference to radio communications. However, there is no guarantee that interference will not occur in a particular installation. If this equipment does cause harmful interference to radio or television reception, which can be determined by turning the equipment off and on, the user is encouraged to try to correct the interference by one or more of the following measures:

- Reorient or relocate the receiving antenna.
- Increase the separation between the equipment and receiver.
- Connect the equipment into an outlet on a circuit different from that to which the receiver is connected.
- Consult the dealer or an experienced radio/TV technician for help.

3.2 Canada

3.2.1 For EVMs issued with an Industry Canada Certificate of Conformance to RSS-210

Concerning EVMs Including Radio Transmitters:

This device complies with Industry Canada license-exempt RSS standard(s). Operation is subject to the following two conditions: (1) this device may not cause interference, and (2) this device must accept any interference, including interference that may cause undesired operation of the device.

Concernant les EVMs avec appareils radio:

Le présent appareil est conforme aux CNR d'Industrie Canada applicables aux appareils radio exempts de licence. L'exploitation est autorisée aux deux conditions suivantes: (1) l'appareil ne doit pas produire de brouillage, et (2) l'utilisateur de l'appareil doit accepter tout brouillage radioélectrique subi, même si le brouillage est susceptible d'en compromettre le fonctionnement.

Concerning EVMs Including Detachable Antennas:

Under Industry Canada regulations, this radio transmitter may only operate using an antenna of a type and maximum (or lesser) gain approved for the transmitter by Industry Canada. To reduce potential radio interference to other users, the antenna type and its gain should be so chosen that the equivalent isotropically radiated power (e.i.r.p.) is not more than that necessary for successful communication. This radio transmitter has been approved by Industry Canada to operate with the antenna types listed in the user guide with the maximum permissible gain and required antenna impedance for each antenna type indicated. Antenna types not included in this list, having a gain greater than the maximum gain indicated for that type, are strictly prohibited for use with this device.

Concernant les EVMs avec antennes détachables

Conformément à la réglementation d'Industrie Canada, le présent émetteur radio peut fonctionner avec une antenne d'un type et d'un gain maximal (ou inférieur) approuvé pour l'émetteur par Industrie Canada. Dans le but de réduire les risques de brouillage radioélectrique à l'intention des autres utilisateurs, il faut choisir le type d'antenne et son gain de sorte que la puissance isotrope rayonnée équivalente (p.i.r.e.) ne dépasse pas l'intensité nécessaire à l'établissement d'une communication satisfaisante. Le présent émetteur radio a été approuvé par Industrie Canada pour fonctionner avec les types d'antenne énumérés dans le manuel d'usage et ayant un gain admissible maximal et l'impédance requise pour chaque type d'antenne. Les types d'antenne non inclus dans cette liste, ou dont le gain est supérieur au gain maximal indiqué, sont strictement interdits pour l'exploitation de l'émetteur.

3.3 Japan

3.3.1 *Notice for EVMs delivered in Japan:* Please see http://www.tij.co.jp/lstds/ti_ja/general/eStore/notice_01.page 日本国内に輸入される評価用キット、ボードについては、次のところをご覧ください。
http://www.tij.co.jp/lstds/ti_ja/general/eStore/notice_01.page

3.3.2 *Notice for Users of EVMs Considered "Radio Frequency Products" in Japan:* EVMs entering Japan may not be certified by TI as conforming to Technical Regulations of Radio Law of Japan.

If User uses EVMs in Japan, not certified to Technical Regulations of Radio Law of Japan, User is required by Radio Law of Japan to follow the instructions below with respect to EVMs:

1. Use EVMs in a shielded room or any other test facility as defined in the notification #173 issued by Ministry of Internal Affairs and Communications on March 28, 2006, based on Sub-section 1.1 of Article 6 of the Ministry's Rule for Enforcement of Radio Law of Japan,
2. Use EVMs only after User obtains the license of Test Radio Station as provided in Radio Law of Japan with respect to EVMs, or
3. Use of EVMs only after User obtains the Technical Regulations Conformity Certification as provided in Radio Law of Japan with respect to EVMs. Also, do not transfer EVMs, unless User gives the same notice above to the transferee. Please note that if User does not follow the instructions above, User will be subject to penalties of Radio Law of Japan.

【無線電波を送信する製品の開発キットをお使いになる際の注意事項】 開発キットの中には技術基準適合証明を受けていないものがあります。技術適合証明を受けていないものご使用に際しては、電波法遵守のため、以下のいずれかの措置を取っていただく必要がありますのでご注意ください。

1. 電波法施行規則第6条第1項第1号に基づく平成18年3月28日総務省告示第173号で定められた電波暗室等の試験設備でご使用いただく。
2. 実験局の免許を取得後ご使用いただく。
3. 技術基準適合証明を取得後ご使用いただく。

なお、本製品は、上記の「ご使用にあたっての注意」を譲渡先、移転先に通知しない限り、譲渡、移転できないものとします。

上記を遵守頂けない場合は、電波法の罰則が適用される可能性があることをご留意ください。日本テキサス・インスツルメンツ株式会社
東京都新宿区西新宿 6 丁目 2 4 番 1 号
西新宿三井ビル

3.3.3 *Notice for EVMs for Power Line Communication:* Please see http://www.tij.co.jp/llds/ti_ja/general/eStore/notice_02.page
電力線搬送波通信についての開発キットをお使いになる際の注意事項については、次のところをご覧ください。http://www.tij.co.jp/llds/ti_ja/general/eStore/notice_02.page

4 *EVM Use Restrictions and Warnings:*

4.1 EVMS ARE NOT FOR USE IN FUNCTIONAL SAFETY AND/OR SAFETY CRITICAL EVALUATIONS, INCLUDING BUT NOT LIMITED TO EVALUATIONS OF LIFE SUPPORT APPLICATIONS.

4.2 User must read and apply the user guide and other available documentation provided by TI regarding the EVM prior to handling or using the EVM, including without limitation any warning or restriction notices. The notices contain important safety information related to, for example, temperatures and voltages.

4.3 *Safety-Related Warnings and Restrictions:*

4.3.1 User shall operate the EVM within TI's recommended specifications and environmental considerations stated in the user guide, other available documentation provided by TI, and any other applicable requirements and employ reasonable and customary safeguards. Exceeding the specified performance ratings and specifications (including but not limited to input and output voltage, current, power, and environmental ranges) for the EVM may cause personal injury or death, or property damage. If there are questions concerning performance ratings and specifications, User should contact a TI field representative prior to connecting interface electronics including input power and intended loads. Any loads applied outside of the specified output range may also result in unintended and/or inaccurate operation and/or possible permanent damage to the EVM and/or interface electronics. Please consult the EVM user guide prior to connecting any load to the EVM output. If there is uncertainty as to the load specification, please contact a TI field representative. During normal operation, even with the inputs and outputs kept within the specified allowable ranges, some circuit components may have elevated case temperatures. These components include but are not limited to linear regulators, switching transistors, pass transistors, current sense resistors, and heat sinks, which can be identified using the information in the associated documentation. When working with the EVM, please be aware that the EVM may become very warm.

4.3.2 EVMs are intended solely for use by technically qualified, professional electronics experts who are familiar with the dangers and application risks associated with handling electrical mechanical components, systems, and subsystems. User assumes all responsibility and liability for proper and safe handling and use of the EVM by User or its employees, affiliates, contractors or designees. User assumes all responsibility and liability to ensure that any interfaces (electronic and/or mechanical) between the EVM and any human body are designed with suitable isolation and means to safely limit accessible leakage currents to minimize the risk of electrical shock hazard. User assumes all responsibility and liability for any improper or unsafe handling or use of the EVM by User or its employees, affiliates, contractors or designees.

4.4 User assumes all responsibility and liability to determine whether the EVM is subject to any applicable international, federal, state, or local laws and regulations related to User's handling and use of the EVM and, if applicable, User assumes all responsibility and liability for compliance in all respects with such laws and regulations. User assumes all responsibility and liability for proper disposal and recycling of the EVM consistent with all applicable international, federal, state, and local requirements.

5. *Accuracy of Information:* To the extent TI provides information on the availability and function of EVMs, TI attempts to be as accurate as possible. However, TI does not warrant the accuracy of EVM descriptions, EVM availability or other information on its websites as accurate, complete, reliable, current, or error-free.

6. *Disclaimers:*
- 6.1 EXCEPT AS SET FORTH ABOVE, EVMS AND ANY WRITTEN DESIGN MATERIALS PROVIDED WITH THE EVM (AND THE DESIGN OF THE EVM ITSELF) ARE PROVIDED "AS IS" AND "WITH ALL FAULTS." TI DISCLAIMS ALL OTHER WARRANTIES, EXPRESS OR IMPLIED, REGARDING SUCH ITEMS, INCLUDING BUT NOT LIMITED TO ANY IMPLIED WARRANTIES OF MERCHANTABILITY OR FITNESS FOR A PARTICULAR PURPOSE OR NON-INFRINGEMENT OF ANY THIRD PARTY PATENTS, COPYRIGHTS, TRADE SECRETS OR OTHER INTELLECTUAL PROPERTY RIGHTS.
 - 6.2 EXCEPT FOR THE LIMITED RIGHT TO USE THE EVM SET FORTH HEREIN, NOTHING IN THESE TERMS AND CONDITIONS SHALL BE CONSTRUED AS GRANTING OR CONFERRING ANY RIGHTS BY LICENSE, PATENT, OR ANY OTHER INDUSTRIAL OR INTELLECTUAL PROPERTY RIGHT OF TI, ITS SUPPLIERS/LICENSORS OR ANY OTHER THIRD PARTY, TO USE THE EVM IN ANY FINISHED END-USER OR READY-TO-USE FINAL PRODUCT, OR FOR ANY INVENTION, DISCOVERY OR IMPROVEMENT MADE, CONCEIVED OR ACQUIRED PRIOR TO OR AFTER DELIVERY OF THE EVM.
7. *USER'S INDEMNITY OBLIGATIONS AND REPRESENTATIONS.* USER WILL DEFEND, INDEMNIFY AND HOLD TI, ITS LICENSORS AND THEIR REPRESENTATIVES HARMLESS FROM AND AGAINST ANY AND ALL CLAIMS, DAMAGES, LOSSES, EXPENSES, COSTS AND LIABILITIES (COLLECTIVELY, "CLAIMS") ARISING OUT OF OR IN CONNECTION WITH ANY HANDLING OR USE OF THE EVM THAT IS NOT IN ACCORDANCE WITH THESE TERMS AND CONDITIONS. THIS OBLIGATION SHALL APPLY WHETHER CLAIMS ARISE UNDER STATUTE, REGULATION, OR THE LAW OF TORT, CONTRACT OR ANY OTHER LEGAL THEORY, AND EVEN IF THE EVM FAILS TO PERFORM AS DESCRIBED OR EXPECTED.
8. *Limitations on Damages and Liability:*
- 8.1 *General Limitations.* IN NO EVENT SHALL TI BE LIABLE FOR ANY SPECIAL, COLLATERAL, INDIRECT, PUNITIVE, INCIDENTAL, CONSEQUENTIAL, OR EXEMPLARY DAMAGES IN CONNECTION WITH OR ARISING OUT OF THESE TERMS AND CONDITIONS OR THE USE OF THE EVMS PROVIDED HEREUNDER, REGARDLESS OF WHETHER TI HAS BEEN ADVISED OF THE POSSIBILITY OF SUCH DAMAGES. EXCLUDED DAMAGES INCLUDE, BUT ARE NOT LIMITED TO, COST OF REMOVAL OR REINSTALLATION, ANCILLARY COSTS TO THE PROCUREMENT OF SUBSTITUTE GOODS OR SERVICES, RETESTING, OUTSIDE COMPUTER TIME, LABOR COSTS, LOSS OF GOODWILL, LOSS OF PROFITS, LOSS OF SAVINGS, LOSS OF USE, LOSS OF DATA, OR BUSINESS INTERRUPTION. NO CLAIM, SUIT OR ACTION SHALL BE BROUGHT AGAINST TI MORE THAN ONE YEAR AFTER THE RELATED CAUSE OF ACTION HAS OCCURRED.
 - 8.2 *Specific Limitations.* IN NO EVENT SHALL TI'S AGGREGATE LIABILITY FROM ANY WARRANTY OR OTHER OBLIGATION ARISING OUT OF OR IN CONNECTION WITH THESE TERMS AND CONDITIONS, OR ANY USE OF ANY TI EVM PROVIDED HEREUNDER, EXCEED THE TOTAL AMOUNT PAID TO TI FOR THE PARTICULAR UNITS SOLD UNDER THESE TERMS AND CONDITIONS WITH RESPECT TO WHICH LOSSES OR DAMAGES ARE CLAIMED. THE EXISTENCE OF MORE THAN ONE CLAIM AGAINST THE PARTICULAR UNITS SOLD TO USER UNDER THESE TERMS AND CONDITIONS SHALL NOT ENLARGE OR EXTEND THIS LIMIT.
9. *Return Policy.* Except as otherwise provided, TI does not offer any refunds, returns, or exchanges. Furthermore, no return of EVM(s) will be accepted if the package has been opened and no return of the EVM(s) will be accepted if they are damaged or otherwise not in a resalable condition. If User feels it has been incorrectly charged for the EVM(s) it ordered or that delivery violates the applicable order, User should contact TI. All refunds will be made in full within thirty (30) working days from the return of the components(s), excluding any postage or packaging costs.
10. *Governing Law:* These terms and conditions shall be governed by and interpreted in accordance with the laws of the State of Texas, without reference to conflict-of-laws principles. User agrees that non-exclusive jurisdiction for any dispute arising out of or relating to these terms and conditions lies within courts located in the State of Texas and consents to venue in Dallas County, Texas. Notwithstanding the foregoing, any judgment may be enforced in any United States or foreign court, and TI may seek injunctive relief in any United States or foreign court.

Mailing Address: Texas Instruments, Post Office Box 655303, Dallas, Texas 75265
Copyright © 2015, Texas Instruments Incorporated

IMPORTANT NOTICE

Texas Instruments Incorporated and its subsidiaries (TI) reserve the right to make corrections, enhancements, improvements and other changes to its semiconductor products and services per JESD46, latest issue, and to discontinue any product or service per JESD48, latest issue. Buyers should obtain the latest relevant information before placing orders and should verify that such information is current and complete. All semiconductor products (also referred to herein as "components") are sold subject to TI's terms and conditions of sale supplied at the time of order acknowledgment.

TI warrants performance of its components to the specifications applicable at the time of sale, in accordance with the warranty in TI's terms and conditions of sale of semiconductor products. Testing and other quality control techniques are used to the extent TI deems necessary to support this warranty. Except where mandated by applicable law, testing of all parameters of each component is not necessarily performed.

TI assumes no liability for applications assistance or the design of Buyers' products. Buyers are responsible for their products and applications using TI components. To minimize the risks associated with Buyers' products and applications, Buyers should provide adequate design and operating safeguards.

TI does not warrant or represent that any license, either express or implied, is granted under any patent right, copyright, mask work right, or other intellectual property right relating to any combination, machine, or process in which TI components or services are used. Information published by TI regarding third-party products or services does not constitute a license to use such products or services or a warranty or endorsement thereof. Use of such information may require a license from a third party under the patents or other intellectual property of the third party, or a license from TI under the patents or other intellectual property of TI.

Reproduction of significant portions of TI information in TI data books or data sheets is permissible only if reproduction is without alteration and is accompanied by all associated warranties, conditions, limitations, and notices. TI is not responsible or liable for such altered documentation. Information of third parties may be subject to additional restrictions.

Resale of TI components or services with statements different from or beyond the parameters stated by TI for that component or service voids all express and any implied warranties for the associated TI component or service and is an unfair and deceptive business practice. TI is not responsible or liable for any such statements.

Buyer acknowledges and agrees that it is solely responsible for compliance with all legal, regulatory and safety-related requirements concerning its products, and any use of TI components in its applications, notwithstanding any applications-related information or support that may be provided by TI. Buyer represents and agrees that it has all the necessary expertise to create and implement safeguards which anticipate dangerous consequences of failures, monitor failures and their consequences, lessen the likelihood of failures that might cause harm and take appropriate remedial actions. Buyer will fully indemnify TI and its representatives against any damages arising out of the use of any TI components in safety-critical applications.

In some cases, TI components may be promoted specifically to facilitate safety-related applications. With such components, TI's goal is to help enable customers to design and create their own end-product solutions that meet applicable functional safety standards and requirements. Nonetheless, such components are subject to these terms.

No TI components are authorized for use in FDA Class III (or similar life-critical medical equipment) unless authorized officers of the parties have executed a special agreement specifically governing such use.

Only those TI components which TI has specifically designated as military grade or "enhanced plastic" are designed and intended for use in military/aerospace applications or environments. Buyer acknowledges and agrees that any military or aerospace use of TI components which have **not** been so designated is solely at the Buyer's risk, and that Buyer is solely responsible for compliance with all legal and regulatory requirements in connection with such use.

TI has specifically designated certain components as meeting ISO/TS16949 requirements, mainly for automotive use. In any case of use of non-designated products, TI will not be responsible for any failure to meet ISO/TS16949.

Products

Audio	www.ti.com/audio
Amplifiers	amplifier.ti.com
Data Converters	dataconverter.ti.com
DLP® Products	www.dlp.com
DSP	dsp.ti.com
Clocks and Timers	www.ti.com/clocks
Interface	interface.ti.com
Logic	logic.ti.com
Power Mgmt	power.ti.com
Microcontrollers	microcontroller.ti.com
RFID	www.ti-rfid.com
OMAP Applications Processors	www.ti.com/omap
Wireless Connectivity	www.ti.com/wirelessconnectivity

Applications

Automotive and Transportation	www.ti.com/automotive
Communications and Telecom	www.ti.com/communications
Computers and Peripherals	www.ti.com/computers
Consumer Electronics	www.ti.com/consumer-apps
Energy and Lighting	www.ti.com/energy
Industrial	www.ti.com/industrial
Medical	www.ti.com/medical
Security	www.ti.com/security
Space, Avionics and Defense	www.ti.com/space-avionics-defense
Video and Imaging	www.ti.com/video

TI E2E Community

e2e.ti.com