

**FEATURES:**

- Typical  $t_{SK(O)}$  (Output Skew) < 250ps
- ESD > 2000V per MIL-STD-883, Method 3015; > 200V using machine model (C = 200pF, R = 0)
- $V_{CC} = 3.3V \pm 0.3V$ , Normal Range
- $V_{CC} = 2.7V$  to  $3.6V$ , Extended Range
- CMOS power levels (0.4 $\mu$ W typ. static)
- All inputs, outputs, and I/O are 5V tolerant
- Supports hot insertion
- Available in SSOP and TSSOP packages

**DRIVE FEATURES:**

- High Output Drivers:  $\pm 24mA$
- Reduced system switching noise

**APPLICATIONS:**

- 5V and 3.3V mixed voltage systems
- Data communication and telecommunication systems

**DESCRIPTION:**

This 16-bit bus transceiver is built using advanced dual metal CMOS technology. This high-speed, low power transceiver is ideal for asynchronous communication between two busses (A and B). The Direction and Output Enable controls are designed to operate this device as either two independent 8-bit transceivers or one 16-bit transceiver. The direction control pin (DIR) controls the direction of data flow. The output enable pin ( $\overline{OE}$ ) overrides the direction control and disables both ports. All inputs are designed with hysteresis for improved noise margin.

All pins can be driven from either 3.3V or 5V devices. This feature allows the use of this device as a translator in a mixed 3.3V/5V supply system.

The LVC16245A has been designed with a  $\pm 24mA$  output driver. This driver is capable of driving a moderate to heavy load while maintaining speed performance.

**FUNCTIONAL BLOCK DIAGRAM**

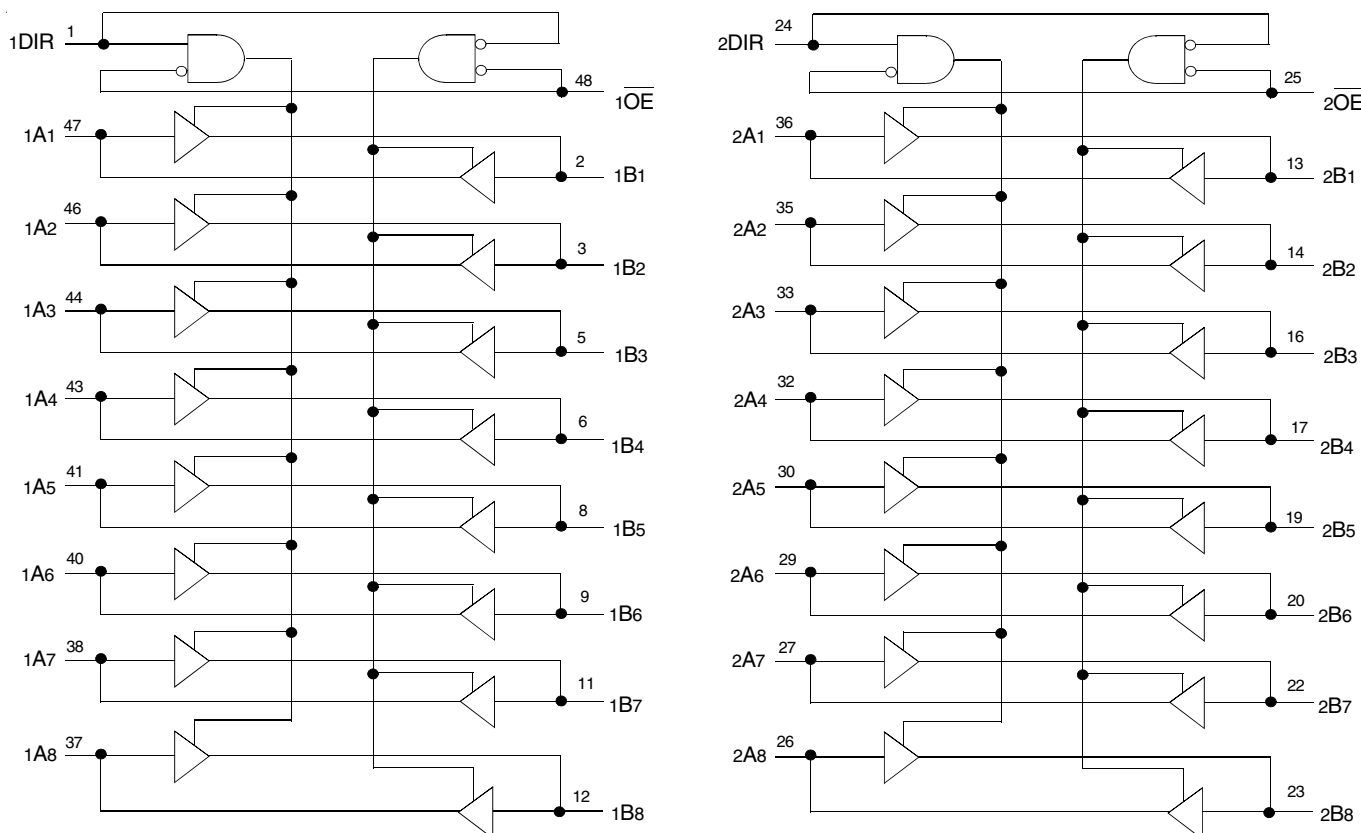

## PIN CONFIGURATION

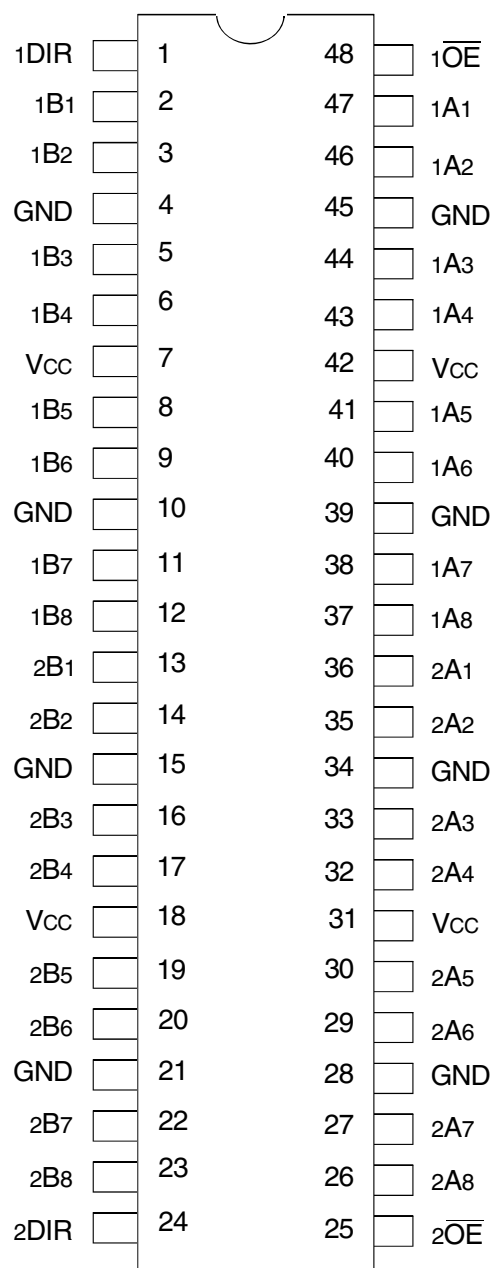

SSOP / TSSOP  
TOP VIEW

## ABSOLUTE MAXIMUM RATINGS<sup>(1)</sup>

Symbol	Description	Max	Unit
VTERM <sup>(2)</sup>	Terminal Voltage with Respect to GND	-0.5 to +6.5	V
VTERM <sup>(3)</sup>	Terminal Voltage with Respect to GND	-0.5 to +6.5	V
TSTG	Storage Temperature	-65 to +150	°C
IOUT	DC Output Current	-50 to +50	mA
I <sub>IK</sub> I <sub>OK</sub>	Continuous Clamp Current, V <sub>I</sub> < 0 or V <sub>O</sub> < 0	-50	mA
I <sub>CC</sub> I <sub>SS</sub>	Continuous Current through each V <sub>CC</sub> or GND	±100	mA

### NOTES:

- Stresses greater than those listed under ABSOLUTE MAXIMUM RATINGS may cause permanent damage to the device. This is a stress rating only and functional operation of the device at these or any other conditions above those indicated in the operational sections of this specification is not implied. Exposure to absolute maximum rating conditions for extended periods may affect reliability.
- V<sub>CC</sub> terminals.
- All terminals except V<sub>CC</sub>.

## CAPACITANCE (T<sub>A</sub> = +25°C, F = 1.0MHz)

Symbol	Parameter <sup>(1)</sup>	Conditions	Typ.	Max.	Unit
C <sub>IN</sub>	Input Capacitance	V <sub>IN</sub> = 0V	4.5	6	pF
C <sub>OUT</sub>	Output Capacitance	V <sub>OUT</sub> = 0V	6.5	8	pF
C <sub>I/O</sub>	I/O Port Capacitance	V <sub>IN</sub> = 0V	6.5	8	pF

### NOTE:

- As applicable to the device type.

## PIN DESCRIPTION

Pin Names	Description
x $\overline{OE}$	Output Enable Inputs (Active LOW)
xDIR	Direction Control Input
xAx	Side A Inputs or 3-State Outputs
xBx	Side B Inputs or 3-State Outputs

## FUNCTION TABLE (EACH 8-BIT SECTION)<sup>(1)</sup>

Inputs		Outputs
x $\overline{OE}$	xDIR	
L	L	Bus B Data to Bus A
L	H	Bus A Data to Bus B
H	X	Z

### NOTES:

- H = HIGH Voltage Level  
X = Don't Care  
L = LOW Voltage Level  
Z = High-Impedance

## DC ELECTRICAL CHARACTERISTICS OVER OPERATING RANGE

Following Conditions Apply Unless Otherwise Specified:

Operating Condition:  $T_A = -40^{\circ}\text{C}$  to  $+85^{\circ}\text{C}$

Symbol	Parameter	Test Conditions		Min.	Typ. <sup>(1)</sup>	Max.	Unit
V <sub>IH</sub>	Input HIGH Voltage Level	V <sub>CC</sub> = 2.3V to 2.7V		1.7	—	—	V
		V <sub>CC</sub> = 2.7V to 3.6V		2	—	—	
V <sub>IL</sub>	Input LOW Voltage Level	V <sub>CC</sub> = 2.3V to 2.7V		—	—	0.7	V
		V <sub>CC</sub> = 2.7V to 3.6V		—	—	0.8	
I <sub>IH</sub> I <sub>IL</sub>	Input Leakage Current	V <sub>CC</sub> = 3.6V	V <sub>I</sub> = 0 to 5.5V	—	—	±5	μA
I <sub>OZH</sub> I <sub>OZL</sub>	High Impedance Output Current (3-State Output pins)	V <sub>CC</sub> = 3.6V	V <sub>O</sub> = 0 to 5.5V	—	—	±10	μA
I <sub>OFF</sub>	Input/Output Power Off Leakage	V <sub>CC</sub> = 0V, V <sub>IN</sub> or V <sub>O</sub> ≤ 5.5V		—	—	±50	μA
V <sub>IK</sub>	Clamp Diode Voltage	V <sub>CC</sub> = 2.3V, I <sub>IN</sub> = -18mA		—	-0.7	-1.2	V
V <sub>H</sub>	Input Hysteresis	V <sub>CC</sub> = 3.3V		—	100	—	mV
I <sub>CCL</sub> I <sub>CCH</sub> I <sub>CCZ</sub>	Quiescent Power Supply Current	V <sub>CC</sub> = 3.6V	V <sub>IN</sub> = GND or V <sub>CC</sub>	—	—	10	μA
			3.6 ≤ V <sub>IN</sub> ≤ 5.5V <sup>(2)</sup>	—	—	10	
ΔI <sub>CC</sub>	Quiescent Power Supply Current Variation	One input at V <sub>CC</sub> - 0.6V, other inputs at V <sub>CC</sub> or GND		—	—	500	μA

NOTES:

- Typical values are at V<sub>CC</sub> = 3.3V, +25°C ambient.
- This applies in the disabled state only.

## OUTPUT DRIVE CHARACTERISTICS

Symbol	Parameter	Test Conditions <sup>(1)</sup>		Min.	Max.	Unit
V <sub>OH</sub>	Output HIGH Voltage	V <sub>CC</sub> = 2.3V to 3.6V	I <sub>OH</sub> = -0.1mA	V <sub>CC</sub> -0.2	—	V
		V <sub>CC</sub> = 2.3V	I <sub>OH</sub> = -6mA	2	—	
		V <sub>CC</sub> = 2.3V	I <sub>OH</sub> = -12mA	1.7	—	
		V <sub>CC</sub> = 2.7V		2.2	—	
		V <sub>CC</sub> = 3V		2.4	—	
		V <sub>CC</sub> = 3V	I <sub>OH</sub> = -24mA	2.2	—	
V <sub>OL</sub>	Output LOW Voltage	V <sub>CC</sub> = 2.3V to 3.6V	I <sub>OL</sub> = 0.1mA	—	0.2	V
		V <sub>CC</sub> = 2.3V	I <sub>OL</sub> = 6mA	—	0.4	
			I <sub>OL</sub> = 12mA	—	0.7	
		V <sub>CC</sub> = 2.7V	I <sub>OL</sub> = 12mA	—	0.4	
		V <sub>CC</sub> = 3V	I <sub>OL</sub> = 24mA	—	0.55	

NOTE:

- V<sub>IH</sub> and V<sub>IL</sub> must be within the min. or max. range shown in the DC ELECTRICAL CHARACTERISTICS OVER OPERATING RANGE table for the appropriate V<sub>CC</sub> range. T<sub>A</sub> = -40°C to +85°C.

OPERATING CHARACTERISTICS,  $V_{CC} = 3.3V \pm 0.3V$ ,  $T_A = 25^\circ C$

Symbol	Parameter	Test Conditions	Typical	Unit
CPD	Power Dissipation Capacitance per Transceiver Outputs enabled	$C_L = 0pF$ , $f = 10MHz$	38	pF
CPD	Power Dissipation Capacitance per Transceiver Outputs disabled		4	

SWITCHING CHARACTERISTICS<sup>(1)</sup>

Symbol	Parameter	$V_{CC} = 2.7V$		$V_{CC} = 3.3V \pm 0.3V$		Unit
		Min.	Max.	Min.	Max.	
$t_{PLH}$ $t_{PHL}$	Propagation Delay xAx to xBx, xBx to xAx	—	4.7	1	4	ns
$t_{PZH}$ $t_{PZL}$	Output Enable Time $\overline{xOE}$ to xAx or xBx	—	6.7	1.5	5.5	ns
$t_{PHZ}$ $t_{PLZ}$	Output Disable Time $\overline{xOE}$ to xAx or xBx	—	7.1	1.5	6.6	ns
$t_{SK(0)}$	Output Skew <sup>(2)</sup>	—	—	—	1	ns

NOTES:

1. See TEST CIRCUITS AND WAVEFORMS.  $T_A = -40^\circ C$  to  $+85^\circ C$ .
2. Skew between any two outputs of the same package and switching in the same direction.

## TEST CIRCUITS AND WAVEFORMS

### TEST CONDITIONS

Symbol	V <sub>CC</sub> <sup>(1)</sup> =3.3V±0.3V	V <sub>CC</sub> <sup>(1)</sup> =2.7V	V <sub>CC</sub> <sup>(2)</sup> =2.5V±0.2V	Unit
V <sub>LOAD</sub>	6	6	2 x V <sub>CC</sub>	V
V <sub>IH</sub>	2.7	2.7	V <sub>CC</sub>	V
V <sub>T</sub>	1.5	1.5	V <sub>CC</sub> / 2	V
V <sub>LZ</sub>	300	300	150	mV
V <sub>HZ</sub>	300	300	150	mV
C <sub>L</sub>	50	50	30	pF

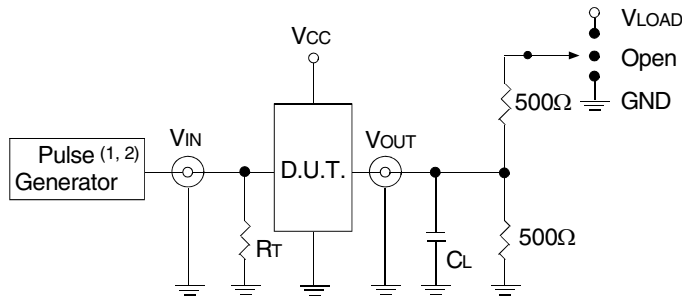

Test Circuit for All Outputs

#### DEFINITIONS:

C<sub>L</sub> = Load capacitance: includes jig and probe capacitance.  
R<sub>T</sub> = Termination resistance: should be equal to Z<sub>OUT</sub> of the Pulse Generator.

#### NOTES:

1. Pulse Generator for All Pulses: Rate ≤ 10MHz; t<sub>r</sub> ≤ 2.5ns; t<sub>r</sub> ≤ 2.5ns.
2. Pulse Generator for All Pulses: Rate ≤ 10MHz; t<sub>r</sub> ≤ 2ns; t<sub>r</sub> ≤ 2ns.

## SWITCH POSITION

Test	Switch
Open Drain Disable Low Enable Low	V <sub>LOAD</sub>
Disable High Enable High	GND
All Other Tests	Open

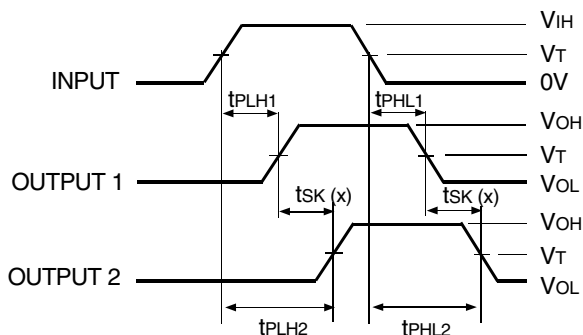

$$tsk(x) = |t_{PLH2} - t_{PLH1}| \text{ or } |t_{PHL2} - t_{PHL1}|$$

Output Skew - tsk(x)

#### NOTES:

1. For tsk(o) OUTPUT1 and OUTPUT2 are any two outputs.
2. For tsk(b) OUTPUT1 and OUTPUT2 are in the same bank.

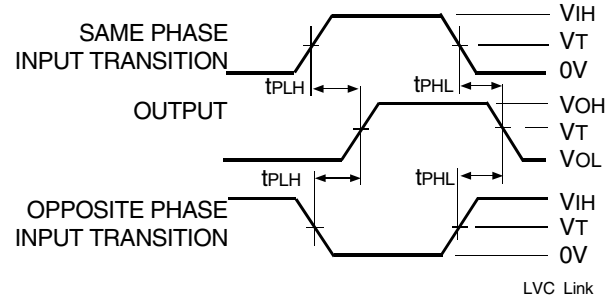

Propagation Delay

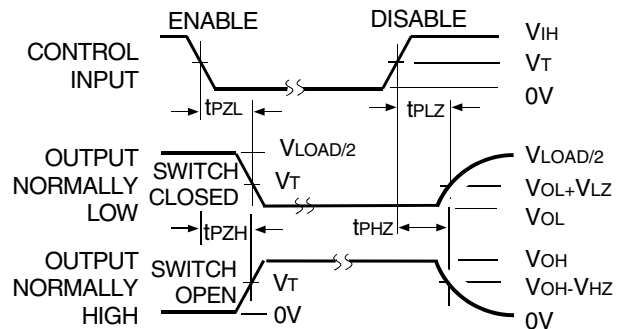

Enable and Disable Times

#### NOTE:

1. Diagram shown for input Control Enable-LOW and input Control Disable-HIGH.

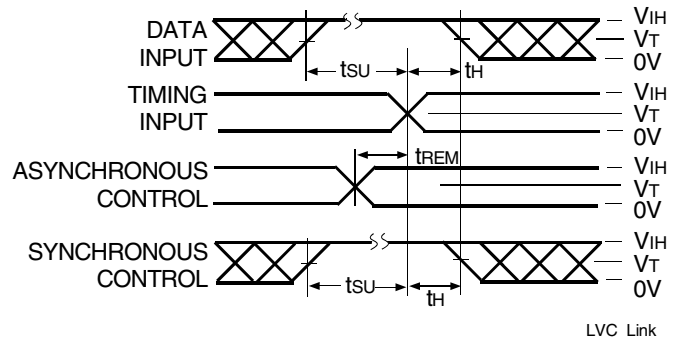

Set-up, Hold, and Release Times

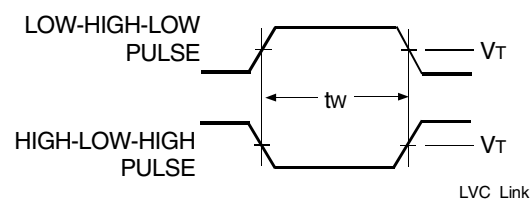

Pulse Width

## ORDERING INFORMATION

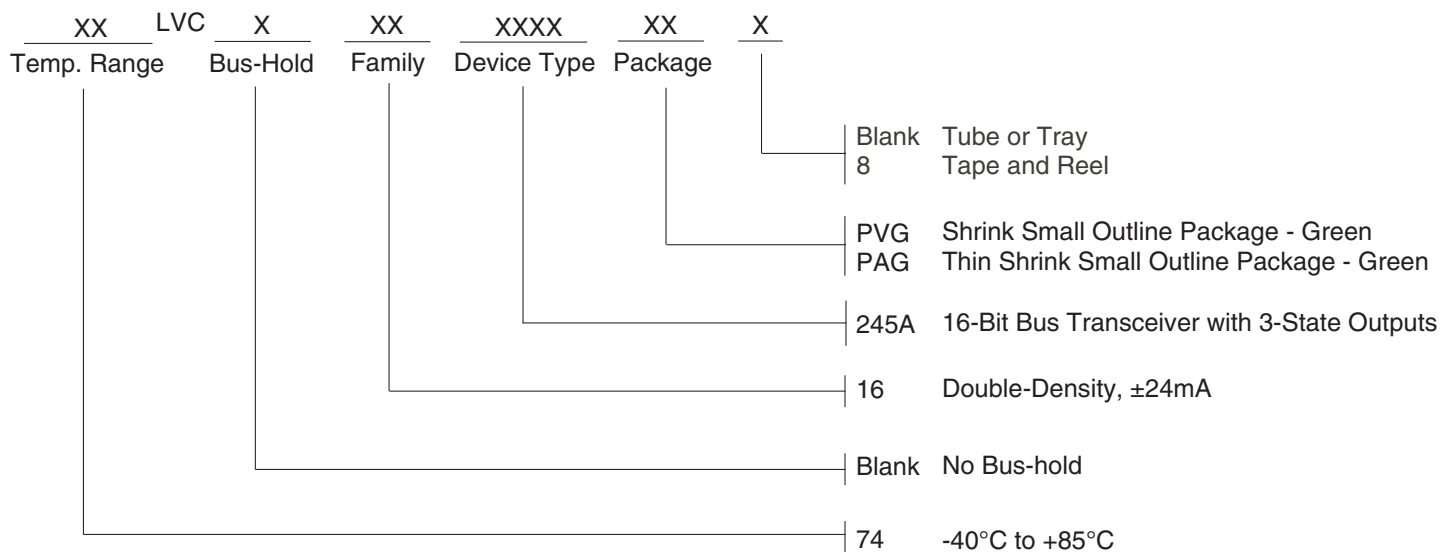

## IMPORTANT NOTICE AND DISCLAIMER

RENESAS ELECTRONICS CORPORATION AND ITS SUBSIDIARIES (“RENESAS”) PROVIDES TECHNICAL SPECIFICATIONS AND RELIABILITY DATA (INCLUDING DATASHEETS), DESIGN RESOURCES (INCLUDING REFERENCE DESIGNS), APPLICATION OR OTHER DESIGN ADVICE, WEB TOOLS, SAFETY INFORMATION, AND OTHER RESOURCES “AS IS” AND WITH ALL FAULTS, AND DISCLAIMS ALL WARRANTIES, EXPRESS OR IMPLIED, INCLUDING, WITHOUT LIMITATION, ANY IMPLIED WARRANTIES OF MERCHANTABILITY, FITNESS FOR A PARTICULAR PURPOSE, OR NON-INFRINGEMENT OF THIRD PARTY INTELLECTUAL PROPERTY RIGHTS.

These resources are intended for developers skilled in the art designing with Renesas products. You are solely responsible for (1) selecting the appropriate products for your application, (2) designing, validating, and testing your application, and (3) ensuring your application meets applicable standards, and any other safety, security, or other requirements. These resources are subject to change without notice. Renesas grants you permission to use these resources only for development of an application that uses Renesas products. Other reproduction or use of these resources is strictly prohibited. No license is granted to any other Renesas intellectual property or to any third party intellectual property. Renesas disclaims responsibility for, and you will fully indemnify Renesas and its representatives against, any claims, damages, costs, losses, or liabilities arising out of your use of these resources. Renesas' products are provided only subject to Renesas' Terms and Conditions of Sale or other applicable terms agreed to in writing. No use of any Renesas resources expands or otherwise alters any applicable warranties or warranty disclaimers for these products.

(Disclaimer Rev.1.0 Mar 2020)

### Corporate Headquarters

TOYOSU FORESIA, 3-2-24 Toyosu,  
Koto-ku, Tokyo 135-0061, Japan  
[www.renesas.com](http://www.renesas.com)

### Contact Information

For further information on a product, technology, the most up-to-date version of a document, or your nearest sales office, please visit:  
[www.renesas.com/contact/](http://www.renesas.com/contact/)

### Trademarks

Renesas and the Renesas logo are trademarks of Renesas Electronics Corporation. All trademarks and registered trademarks are the property of their respective owners.